

# ACCU ELECTRIC MOTORS INC

USA: (888) 932-9183

CANADA: (905) 829-2505

- ✓ Over 100 years cumulative experience
- ✓ 24 hour rush turnaround / technical support service
- ✓ Established in 1993



The leading independent repairer of servo motors and drives in North America.

Visit us on the web:

[www.servo-repair.com](http://www.servo-repair.com)

[www.servorepair.ca](http://www.servorepair.ca)

[www.ferrocontrol.com](http://www.ferrocontrol.com)  
[www.sandvikrepair.com](http://www.sandvikrepair.com)  
[www.accuelectric.com](http://www.accuelectric.com)

**Scroll down to view your document!**

For 24/7 repair services :

USA: 1 (888) 932 - 9183

Canada: 1 (905) 829 -2505

Emergency After hours: 1 (416) 624 0386

Servicing USA and Canada

# MaxPlus® Series Rotary Motors



## MaxPlus® Brushless Rotary Servo Motors

The MaxPlus family is redefining performance, flexibility and reliability, with the industry's broadest range of brushless servo motors – from 1 1/2" to 12" (40 mm to 320 mm). Each unit delivers more performance in a smaller package for less cost. What's more, the reliability of MaxPlus Series motors is becoming legendary in demanding applications. Our rugged construction and industry-leading performance features give you an unbeatable price/performance/cost of ownership combination.

MaxPlus is not just an "off the shelf" line of servo motors. It is a line that offers unparalleled flexibility to achieve precise application requirements. What's more, Compumotor is committed to working with our customers to custom design solutions that meet specific performance and cost criteria.

MaxPlus is the only motor line with such performance specs as more torque to volume, more torque to inertia and more torque per dollar. The full line of MaxPlus brushless servo motors outperforms competitive units in virtually every performance category.

### MaxPlus Rotary Motor Features

- High-performance neodymium magnet material
- Resolver and encoder feedback
- Custom windings available
- IP65 sealing for washdown environments standard
- MS connector termination or flying lead termination
- Thermal sensor with windings
- Optional internally mounted brake
- Optional additional feedback transducers
- Optional gear reducers



Model #	Size (Inches)	Horsepower (HP)	Max Operating Speed (RPM)	Speed at Rated Torque (RPM)	Peak Torque (IN-LBS (Nm))	Model #	Size (Inches)	Horsepower (HP)	Max Operating Speed (RPM)	Speed at Rated Torque (RPM)	Peak Torque (IN-LBS (Nm))
MPM401ASE	1.5"	0.027	6000	4800	1.5 / 0.17	MPM1421ASG	6"	4.4	2700	2400	390.0 / 44
MPM401BSE	1.5"	0.022	5200	3600	1.6 / 0.18	MPM1421BSG	6"	2.9	1750	1500	390.0 / 44
MPM401CSE	1.5"	0.016	4400	2500	1.7 / 0.19	MPM1421CSJ	6"	4.9	3400	2800	390.0 / 44
MPM402ASE	1.5"	0.065	6000	4800	3.5 / 0.39	MPM1421DSJ	6"	2.9	1750	1500	390.0 / 44
MPM402BSE	1.5"	0.059	5200	4100	3.5 / 0.39	MPM1422ASG	6"	6.8	2700	2400	630.0 / 71
MPM402CSE	1.5"	0.054	4400	3500	3.6 / 0.41	MPM1422BSG	6"	4.5	1750	1500	630.0 / 71
MPM403ASE	1.5"	0.093	6000	4800	3.7 / 0.41	MPM1422CSJ	6"	7.6	3400	2800	630.0 / 71
MPM403BSE	1.5"	0.085	5200	4100	4.7 / 0.53	MPM1422DSJ	6"	4.5	1750	1500	630.0 / 71
MPM403CSE	1.5"	0.078	4400	3500	4.9 / 0.55	MPM1423ASG	6"	9.1	2700	2400	840.0 / 95
MPM404ASE	1.5"	0.11	6000	4800	5.3 / 0.59	MPM1423BSG	6"	6.0	1750	1500	840.0 / 95
MPM404BSE	1.5"	0.10	5200	4100	5.4 / 0.61	MPM1423CSJ	6"	9.8	3400	2800	840.0 / 95
MPM404CSE	1.5"	0.093	4400	3500	5.6 / 0.63	MPM1423DSJ	6"	6.0	1750	1500	840.0 / 95
MPM661ASF	2"	0.15	6000	4000	9.7 / 1.1	MPM1424ASG	6"	10	2700	2100	1081.0 / 120
MPM661BSF	2"	0.091	3000	2500	9.5 / 1.1	MPM1424BSG	6"	7.6	1750	1500	1081.0 / 120
MPM662ASF	2"	0.22	5000	4000	15.1 / 1.7	MPM1424CSJ	6"	12	3400	2800	1081.0 / 120
MPM662BSF	2"	0.16	3000	2500	15.1 / 1.7	MPM1424DSJ	6"	7.6	1750	1500	1081.0 / 120
MPM663ASF	2"	0.36	5500	4500	22.5 / 2.5	MPM1901ASG	8"	13	3000	2400	1200.0 / 140
MPM663BSF	2"	0.19	3300	2000	22.5 / 2.5	MPM1901BSG	8"	6.5	1500	1200	1200.0 / 140
MPM664ASF	2"	0.48	6000	5000	30.0 / 3.4	MPM1901CSJ	8"	13	3000	2400	1200.0 / 140
MPM664BSF	2"	0.38	3600	3000	30.0 / 3.4	MPM1901DSJ	8"	6.5	1500	1200	1200.0 / 140
MPM721ASF	2.75"	0.41	6800	5500	17.0 / 1.9	MPM1902ASG	8"	21	3000	2400	1780.0 / 200
MPM721BSG	2.75"	0.41	6800	5500	17.0 / 1.9	MPM1902BSG	8"	10	1500	1200	1920.0 / 220
MPM721CSG	2.75"	0.24	4000	3000	17.0 / 1.9	MPM1902CSJ	8"	21	3000	2400	1920.0 / 220
MPM722ASF	2.75"	0.75	7000	5000	34.0 / 3.8	MPM1902DSJ	8"	10	1500	1200	1920.0 / 220
MPM722BSG	2.75"	0.75	7000	5000	34.0 / 3.8	MPM1903ASG	8"	29	3000	2400	1780.0 / 200
MPM722CSG	2.75"	0.48	4000	3000	34.0 / 3.8	MPM1903BSG	8"	14	1500	1200	2640.0 / 300
MPM723ASF	2.75"	0.91	6300	4500	45.0 / 5.1	MPM1903CSJ	8"	29	3000	2400	2640.0 / 300
MPM723BSG	2.75"	0.91	6300	4500	45.0 / 5.1	MPM1903DSJ	8"	14	1500	1200	2640.0 / 300
MPM723CSG	2.75"	0.63	4000	3000	45.0 / 5.1	MPM1904ASG	8"	36	3000	2400	1780.0 / 200
MPM724ASF	2.75"	1.3	6000	5000	56.0 / 6.3	MPM1904BSG	8"	18	1500	1200	3276.0 / 370
MPM724BSG	2.75"	1.3	6000	5000	56.0 / 6.3	MPM1904CSJ	8"	36	3000	2400	3276.0 / 370
MPM724CSG	2.75"	0.79	4000	3000	56.0 / 6.3	MPM1904DSJ	8"	18	1500	1200	3276.0 / 370
MPM891ASG	3"	0.83	5000	4000	58.8 / 6.6	MPM3201R**-A*					
MPM891BSG	3"	0.55	3000	2400	58.8 / 6.6	MPM3201R**-B*					
MPM892ASG	3"	1.6	5000	4000	109.9 / 12	MPM3201R**-C*					
MPM892BSG	3"	1.0	3000	2400	111.5 / 13	MPM3201R**-A*0					
MPM893ASG	3"	2.0	4100	3600	143.2 / 16	MPM3201R**-B*0					
MPM893BSG	3"	0.86	2000	1500	137.6 / 16	MPM3201R**-C*0					
MPM1141ASG	4"	2.1	4200	3000	189.0 / 21	MPM3202R**-B*					
MPM1141BSG	4"	1.2	2100	1500	189.0 / 21	MPM3202R**-C*					
MPM1141CSJ	4"	2.1	4200	3000	189.0 / 21	MPM3202R**-D*					
MPM1141DSJ	4"	1.2	2100	1500	189.0 / 21	MPM3202R**-B*0					
MPM1142ASG	4"	3.3	4200	3000	291.0 / 33	MPM3202R**-C*0					
MPM1142BSG	4"	1.8	2100	1500	291.0 / 33	MPM3202R**-D*0					
MPM1142CSJ	4"	3.3	4200	3000	291.0 / 33	MPM3203R**-B*					
MPM1142DSJ	4"	1.8	2100	1500	291.0 / 33	MPM3203R**-C*					
MPM1143ASG	4"	4.6	4200	3000	407.0 / 46	MPM3203R**-D*					
MPM1143BSG	4"	2.5	2100	1500	407.0 / 46	MPM3203R**-B*0					
MPM1143CSJ	4"	4.6	4200	3000	407.0 / 46	MPM3203R**-C*0					
MPM1143DSJ	4"	2.5	2100	1500	407.0 / 46	MPM3203R**-D*0					
						MPM3204R**-B*					
						MPM3204R**-C*					
						MPM3204R**-D*					
						MPM3204R**-B*0					
						MPM3204R**-C*0					
						MPM3204R**-D*0					

Consult Factory



**Custom Designed Servo Motors For Your Specific Application. Call 1-800-358-9070 Today.**

MPM	114	1	A	S	G	7	JN	1	N
MAX PLUS MOTOR	FRAME SIZE	STACK LENGTH	WINDING	AMP TYPE	VOLTAGE	MOUNTING	FEEDBACK	TERMINATION	BRAKE OPTION
MPM - STANDARD	40 (1.5")	1	A	S=SINUSOIDAL	LINE	6=ENGLISH	G=RESOLVER (STANDARD)	1=CONNECTOR (STANDARD)	R=24V SPRING
MPF - FOOD GRADE	66 (2")	2	B	T=TRAPEZOIDAL	E=54 VAC	7=METRIC	J=ENCODER (STANDARD)	2=CONNECTOR (INTERCON)	N=NONE
	72 (2 3/4")	3	C	X=SPECIAL*	F=110VAC	8=ENG FOOT MOUNT*	M=1000L	3=PIPE THREAD (NPT)	X=SPECIAL*
	89 (3")	4	D		G=230VAC	9=MET FOOT MOUNT*	N=2000L	4=FLYING LEADS (1.5")	
	114 (4")	5*	X=SPECIAL*		J=460VAC	X=SPECIAL*	L=2500L	X=SPECIAL*	
	142 (6")	6*			X=SPECIAL*		P=3000L		
	190 (8")						Q=5000L		
							T=6000L		
							X=1024L		
							Y=2048L		
							Z=4096L		
							X=SPECIAL*		

\*\*\* OR "X=SPECIAL\*" - Consult Factory  
 The sample part number shown above will be superceding MPM1141T2M-AM  
 \*\*Please reference separate part numbering chart for the 12" motors.

**Resolver**

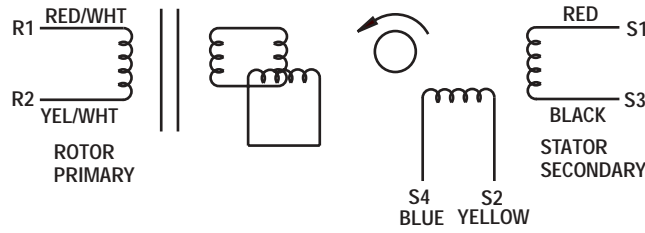

SCHEMATIC DRAWING FOR  
 BRUSHLESS RESOLVER

**Motor Winding**

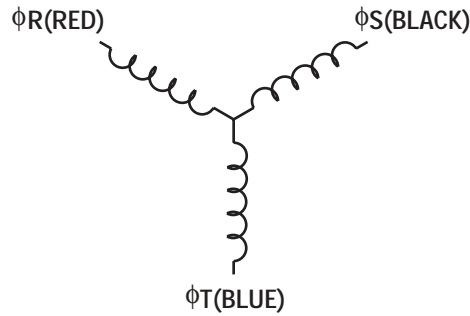

3 PHASE - 4 POLE                      3 PHASE - 6 POLE  
 1 1/2" - 55mm - 2" MOTORS      2 3/4" - 3" - 4" - 8" MOTORS

**Encoder**

MOTOR & HALL POSITION CHART

HALL LEADS	BROWN	GRAY	WHITE
MOTOR LEADS	BLACK respect to RED	RED respect to BLUE	BLUE respect to BLACK
VIEW ON THE OSCILLOSCOPE			

\*MOTOR ROTATION CCW (COUNTER CLOCKWISE)  
 (LOOKING AT THE FACE OF THE MOTOR)

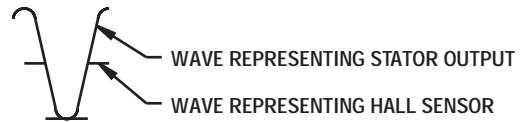

Custom Designed Servo Motors For Your Specific Application. Call 1-800-358-9070 Today.

# 1 1/2" Frame Brushless Servo Motors



## Motor Data (Sine)

Motor Parameters		Units	401ASE****	401BSE****	401CSE****	402ASE****	402BSE****	402CSE****
Horsepower	Hp Rated	Hp	0.027	0.022	0.016	0.065	0.059	0.054
Kilowatts	Watts Rated	Watts	20.0	16.0	12.0	48.0	44.0	40.0
Max. Operating Speed	N Max	RPM	6000	5200	4400	6000	5200	4400
Speed @ Rated Torque	N Rated	RPM	4800	3600	2500	4800	4100	3500
*Continuous Rated Torque @ Rated Speed		IN-LBS[Nm]	0.36[0.041]	0.38[0.043]	0.41[0.047]	0.85[0.096]	0.90[0.10]	0.98[0.11]
*Continuous Stall Torque		IN-LBS[Nm]	0.51[0.058]	0.53[0.060]	0.56[0.063]	1.15[0.13]	1.16[0.13]	1.20[0.14]
Continuous Line Current		AMPS(RMS/φ)	1.00	0.50	0.36	2.29	1.10	0.79
Peak Torque	Tpk	IN-LBS[Nm]	1.53[0.173]	1.59[0.180]	1.68[0.190]	3.45[0.39]	3.48[0.39]	3.60[0.41]
Peak Current		AMPS(RMS/φ)	2.99	1.51	1.07	6.88	3.32	2.35
Max. Theoretical Accel.		RAD/SEC <sup>2</sup>	110,000	110,000	120,000	140,000	140,000	140,000
Torque Sensitivity	Kt	IN-LBS/AMP(RMS/φ)[Nm/AMP(RMS/φ)]	0.51[0.057]	1.05[0.118]	1.56[0.176]	0.51[0.057]	1.05[0.118]	1.53[0.172]
Back EMF (Line to Line)	±10%	Vrms/Krpm	3.2	6.6	9.8	3.2	6.6	9.6
D.C. Resistance (P-P)	±10%	OHMS	5.9	23.0	58.0	2.0	7.7	18.0
Inductance (P-P)	±10%	MILLIHENRIES	1.8	7.3	16.0	0.71	2.8	6.4
Rotor Inertia	Jm	IN-LBS-SEC <sup>2</sup> [Kg-M <sup>2</sup> ]	.000014[.0000016]	.000014[.0000016]	.000014[.0000016]	.000025[.0000028]	.000025[.0000028]	.000025[.0000028]
Static Friction	Tf	IN-LBS[Nm]	0.09[0.010]	0.09[0.010]	0.09[0.010]	0.11[0.012]	0.11[0.012]	0.11[0.012]
Motor Weight		LBS[Kg]	1.0[0.45]	1.0[0.45]	1.0[0.45]	1.2[0.54]	1.2[0.54]	1.2[0.54]
Line Voltage		VAC	54	54	54	54	54	54

Motor Parameters		Units	403ASE****	403BSE****	403CSE****	404ASE****	404BSE****	404CSE****
Horsepower	Hp Rated	Hp	0.093	0.085	0.078	0.110	0.101	0.093
Kilowatts	Watts Rated	Watts	69.0	63.0	58.0	82.0	75.0	69.0
Max. Operating Speed	N Max	RPM	6000	5200	4400	6000	5200	4400
Speed @ Rated Torque	N Rated	RPM	4800	4100	3500	4800	4100	3500
*Continuous Rated Torque @ Rated Speed		IN-LBS[Nm]	1.22[0.14]	1.30[0.15]	1.40[0.16]	1.45[0.16]	1.55[0.18]	1.67[0.19]
*Continuous Stall Torque		IN-LBS[Nm]	1.52[0.17]	1.56[0.18]	1.63[0.18]	1.75[0.20]	1.81[0.20]	1.87[0.21]
Continuous Line Current		AMPS(RMS/φ)	3.07	1.53	1.06	3.53	1.78	1.22
Peak Torque	Tpk	IN-LBS[Nm]	3.66[0.41]	4.68[0.53]	4.88[0.55]	5.25[0.59]	5.43[0.61]	5.60[0.63]
Peak Current		AMPS(RMS/φ)	7.38	4.60	3.18	10.6	5.35	3.65
Max. Theoretical Accel.		RAD/SEC <sup>2</sup>	100,000	130,000	130,000	110,000	110,000	120,000
Torque Sensitivity	Kt	IN-LBS/AMP(RMS/φ)[Nm/AMP(RMS/φ)]	0.49[0.056]	1.02[0.115]	1.54[0.174]	0.49[0.056]	1.02[0.115]	1.54[0.174]
Back EMF (Line to Line)	±10%	Vrms/Krpm	3.1	6.4	9.7	3.1	6.4	9.7
D.C. Resistance (P-P)	±10%	OHMS	1.1	4.4	9.8	0.86	2.9	7.1
Inductance (P-P)	±10%	MILLIHENRIES	0.42	1.8	4.0	0.36	1.3	3.0
Rotor Inertia	Jm	IN-LBS-SEC <sup>2</sup> [Kg-M <sup>2</sup> ]	.000036[.0000041]	.000036[.0000041]	.000036[.0000041]	.000048[.0000054]	.000048[.0000054]	.000048[.0000054]
Static Friction	Tf	IN-LBS[Nm]	0.13[0.015]	0.13[0.015]	0.13[0.015]	0.15[0.017]	0.15[0.017]	0.15[0.017]
Motor Weight		LBS[Kg]	1.4[0.64]	1.4[0.64]	1.4[0.64]	1.6[0.73]	1.6[0.73]	1.6[0.73]
Line Voltage		VAC	54	54	54	54	54	54

\*25° C Ambient with a maximum case temperature of 85° C on motor. Motor mounted on a 6" x 6" x 1/4" aluminum heatsink. Thermostat in stator windings will open if winding temperature exceeds 130° C for an approximate 10% headroom in the continuous torque rating before thermostat opens.

Mechanical Notes:

1. Axial Load: 10 LBS. Max.
2. Radial Load: 15 LBS. Max. @ 1" from face
3. Motor sealed to IP65

**Motor Data (Trap)**

Motor Parameters		Units	401ATE****	401BTE****	401CTE****	402ATE****	402BTE****	402CTE****
Horsepower	Hp Rated	Hp	0.027	0.022	0.016	0.065	0.059	0.054
Kilowatts	Watts Rated	Watts	20.0	16.0	12.0	48.0	44.0	40.0
Max. Operating Speed	N Max	RPM	6000	5200	4400	6000	5200	4400
Speed @ Rated Torque	N Rated	RPM	4800	3600	2500	4800	4100	3500
*Continuous Rated Torque @ Rated Speed		IN-LBS [Nm]	0.36 [0.041]	0.38 [0.043]	0.41 [0.047]	0.85 [0.096]	0.90 [0.10]	0.98 [0.11]
*Continuous Stall Torque		IN-LBS [Nm]	0.51 [0.058]	0.53 [0.060]	0.56 [0.063]	1.15 [0.13]	1.16 [0.13]	1.20 [0.14]
Continuous Line Current		AMPS	1.41	0.71	0.51	3.24	1.56	1.11
Peak Torque	Tpk	IN-LBS [Nm]	1.53 [0.173]	1.59 [0.180]	1.68 [0.190]	3.45 [0.39]	3.48 [0.39]	3.60 [0.41]
Peak Current		AMPS	4.23	2.14	1.52	9.73	4.69	3.32
Max. Theoretical Accel.		RAD/SEC <sup>2</sup>	110,000	110,000	120,000	140,000	140,000	140,000
Torque Sensitivity	Kt	IN-LBS/AMP [Nm/AMP]	0.36 [0.041]	0.74 [0.084]	1.10 [0.124]	0.35 [0.040]	0.74 [0.084]	1.08 [0.122]
Back EMF (Line to Line)	±10%	Vrms/Krpm	32	66	98	32	66	96
D.C. Resistance (P-P)	±10%	OHMS	5.9	23.0	580	20	7.7	180
Inductance (P-P)	±10%	MILLIHENRIES	1.8	7.3	160	0.71	2.8	6.4
Rotor Inertia	Jm	IN-LBS-SEC <sup>2</sup> [Kg-M <sup>2</sup> ]	.000014 [.0000016]	.000014 [.0000016]	.000014 [.0000016]	.000025 [.0000028]	.000025 [.0000028]	.000025 [.0000028]
Static Friction	Tf	IN-LBS [Nm]	0.09 [0.010]	0.09 [0.010]	0.09 [0.010]	0.11 [0.012]	0.11 [0.012]	0.11 [0.012]
Motor Weight		LBS [Kg]	1.0 [0.45]	1.0 [0.45]	1.0 [0.45]	1.2 [0.54]	1.2 [0.54]	1.2 [0.54]
Line Voltage		VAC	54	54	54	54	54	54

Motor Parameters		Units	403ATE****	403BTE****	403CTE****	404ATE****	404BTE****	404CTE****
Horsepower	Hp Rated	Hp	0.093	0.085	0.078	0.110	0.101	0.093
Kilowatts	Watts Rated	Watts	69.0	63.0	58.0	82.0	75.0	69.0
Max. Operating Speed	N Max	RPM	6000	5200	4400	6000	5200	4400
Speed @ Rated Torque	N Rated	RPM	4800	4100	3500	4800	4100	3500
*Continuous Rated Torque @ Rated Speed		IN-LBS [Nm]	1.22 [0.14]	1.30 [0.15]	1.40 [0.16]	1.45 [0.16]	1.55 [0.18]	1.67 [0.19]
*Continuous Stall Torque		IN-LBS [Nm]	1.52 [0.17]	1.56 [0.18]	1.63 [0.18]	1.75 [0.20]	1.81 [0.20]	1.87 [0.21]
Continuous Line Current		AMPS	4.34	2.17	1.50	4.99	2.52	1.72
Peak Torque	Tpk	IN-LBS [Nm]	3.66 [0.41]	4.68 [0.53]	4.88 [0.55]	5.25 [0.59]	5.43 [0.61]	5.60 [0.63]
Peak Current		AMPS	10.44	6.51	4.49	15.0	7.56	5.16
Max. Theoretical Accel.		RAD/SEC <sup>2</sup>	100,000	130,000	130,000	110,000	110,000	120,000
Torque Sensitivity	Kt	IN-LBS/AMP [Nm/AMP]	0.35 [0.039]	0.72 [0.081]	1.09 [0.123]	0.35 [0.040]	0.72 [0.081]	1.09 [0.123]
Back EMF (Line to Line)	±10%	Vrms/Krpm	3.1	6.4	9.7	3.1	6.4	9.7
D.C. Resistance (P-P)	±10%	OHMS	1.1	4.4	9.8	0.86	2.9	7.1
Inductance (P-P)	±10%	MILLIHENRIES	0.42	1.8	4.0	0.36	1.3	3.0
Rotor Inertia	Jm	IN-LBS-SEC <sup>2</sup> [Kg-M <sup>2</sup> ]	.000036 [.0000041]	.000036 [.0000041]	.000036 [.0000041]	.000048 [.0000054]	.000048 [.0000054]	.000048 [.0000054]
Static Friction	Tf	IN-LBS [Nm]	0.13 [0.015]	0.13 [0.015]	0.13 [0.015]	0.15 [0.017]	0.15 [0.017]	0.15 [0.017]
Motor Weight		LBS [Kg]	1.4 [0.64]	1.4 [0.64]	1.4 [0.64]	1.6 [0.73]	1.6 [0.73]	1.6 [0.73]
Line Voltage		VAC	54	54	54	54	54	54

\*25° C Ambient with a maximum case temperature of 85° C on motor. Motor mounted on a 6" x 6" x 1/4" aluminum heatsink. Thermostat in stator windings will open if winding temperature exceeds 130° C for an approximate 0% headroom in the continuous or quartering before the thermostat opens.

Mechanical Notes:

1. Axial Load: 10 LBS. Max.
2. Radial Load: 15 LBS. Max. @ 1" from face
3. Motor sealed to IP65

**Custom Designed Servo Motors For Your Specific Application. Call 1-800-358-9070 Today.**

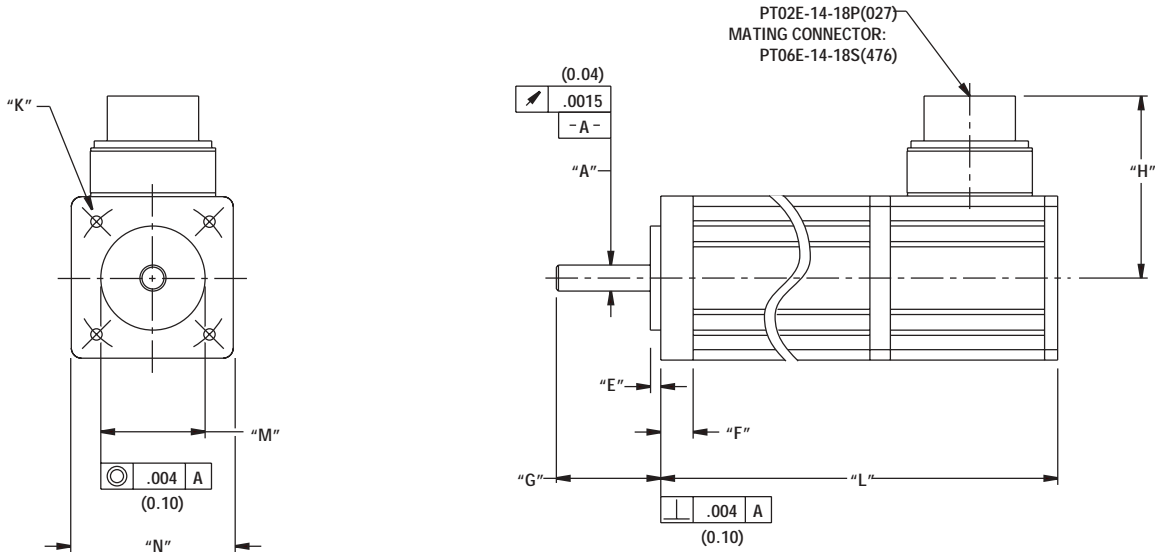

**1 1/2" (40)English and Metric Connectorized Termination-Option 1 Motors**

Model	"A"	"D"	"F"	"G"	"H"
MPM401****6***	∅ 2500(6.350) ∅ 2495(6.337)	.10(2.5)	31(7.9)	1.02(25.9) .98(24.9)	1.76(44.7)Max
MPM401****7***	∅ 6.000(.2362) ∅ 5.992(.2359)	2.5(.10)	7.9(.31)	25.4(1.00) 24.4(.96)	44.7(1.76)Max
MPM402****6***	∅ 2500(6.350) ∅ 2495(6.337)	.10(2.5)	31(7.9)	1.02(25.9) .98(24.9)	1.76(44.7)Max
MPM402****7***	∅ 6.000(.2362) ∅ 5.992(.2359)	2.5(.10)	7.9(.31)	25.4(1.00) 24.4(.96)	44.7(1.76)Max
MPM403****6***	∅ 2500(6.350) ∅ 2495(6.337)	.10(2.5)	31(7.9)	1.02(25.9) .98(24.9)	1.76(44.7)Max
MPM403****7***	∅ 6.000(.2362) ∅ 5.992(.2359)	2.5(.10)	7.9(.31)	25.4(1.00) 24.4(.96)	44.7(1.76)Max
MPM404****6***	∅ 2500(6.350) ∅ 2495(6.337)	.10(2.5)	31(7.9)	1.02(25.9) .98(24.9)	1.76(44.7)Max
MPM404****7***	∅ 6.000(.2362) ∅ 5.992(.2359)	2.5(.10)	7.9(.31)	25.4(1.00) 24.4(.96)	44.7(1.76)Max

Model	"K"	"L"	"M"	"N"
MPM401****6***	#6-32UNC-2B∇ 250(6.35)(4)EQ SPD AS SHOWN ON ∅ 1.531(38.89) B.C.	3.83(97.3)Max	∅ 1.000(25.40) ∅ .998(25.35)	□ 1.575(40.00)
MPM401****7***	M3 X .5∇ 6.35(.250)(4)EQ SPD AS SHOWN ON ∅ 46.00(1.811) B.C.	97.3(3.83)Max	∅ 30.00(1.181) ∅ 29.79(1.173)	□ 40.00(1.575)
MPM402****6***	#6-32UNC-2B∇ 250(6.35)(4)EQ SPD AS SHOWN ON ∅ 1.531(38.89) B.C.	4.33(110.0)Max	∅ 1.000(25.40) ∅ .998(25.35)	□ 1.575(40.00)
MPM402****7***	M3 X .5∇ 6.35(.250)(4)EQ SPD AS SHOWN ON ∅ 46.00(1.811) B.C.	110.0(4.33)Max	∅ 30.00(1.181) ∅ 29.79(1.173)	□ 40.00(1.575)
MPM403****6***	#6-32UNC-2B∇ 250(6.35)(4)EQ SPD AS SHOWN ON ∅ 1.531(38.89) B.C.	4.83(122.7)Max	∅ 1.000(25.40) ∅ .998(25.35)	□ 1.575(40.00)
MPM403****7***	M3 X .5∇ 6.35(.250)(4)EQ SPD AS SHOWN ON ∅ 46.00(1.811) B.C.	122.7(4.83)Max	∅ 30.00(1.181) ∅ 29.79(1.173)	□ 40.00(1.575)
MPM404****6***	#6-32UNC-2B∇ 250(6.35)(4)EQ SPD AS SHOWN ON ∅ 1.531(38.89) B.C.	5.33(135.4)Max	∅ 1.000(25.40) ∅ .998(25.35)	□ 1.575(40.00)
MPM404****7***	M3 X .5∇ 6.35(.250)(4)EQ SPD AS SHOWN ON ∅ 46.00(1.811) B.C.	135.4(5.33)Max	∅ 30.00(1.181) ∅ 29.79(1.173)	□ 40.00(1.575)

English = 6 Units: in (mm)  
 Metric = 7 Units: in (mm)

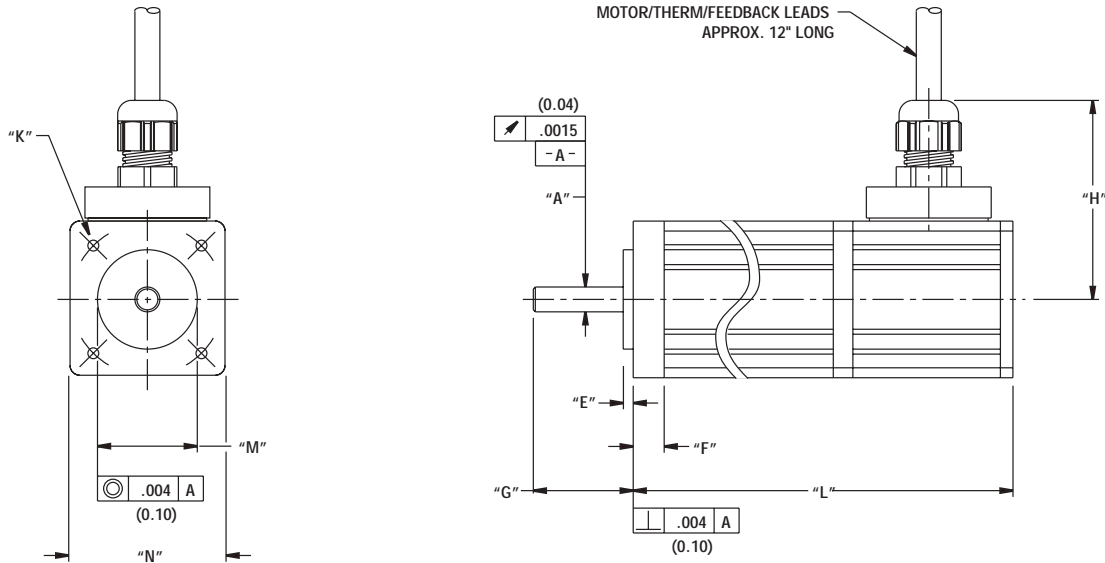

**1 1/2" (40)English and Metric Flying Leads Termination-Option 4 Motors**

Model	"A"	"E"	"F"	"G"	"H"
MPM401***6***	∅ .2500 (6.350) .2495 (6.337)	.10 (2.5)	31 (7.9)	1.02 (25.9) .98 (24.9)	2.00 (58.0) Max
MPM401***7***	∅ 6.000 (.2362) 5.992 (.2359)	2.5 (1.0)	7.9 (.31)	25.4 (1.00) 24.4 (.96)	50.8 (2.00) Max
MPM402***6***	∅ .2500 (6.350) .2495 (6.337)	.10 (2.5)	31 (7.9)	1.02 (25.9) .98 (24.9)	2.00 (58.0) Max
MPM402***7***	∅ 6.000 (.2362) 5.992 (.2359)	2.5 (1.0)	7.9 (.31)	25.4 (1.00) 24.4 (.96)	50.8 (2.00) Max
MPM403***6***	∅ .2500 (6.350) .2495 (6.337)	.10 (2.5)	31 (7.9)	1.02 (25.9) .98 (24.9)	2.00 (58.0) Max
MPM403***7***	∅ 6.000 (.2362) 5.992 (.2359)	2.5 (1.0)	7.9 (.31)	25.4 (1.00) 24.4 (.96)	50.8 (2.00) Max
MPM404***6***	∅ .2500 (6.350) .2495 (6.337)	.10 (2.5)	31 (7.9)	1.02 (25.9) .98 (24.9)	2.00 (58.0) Max
MPM404***7***	∅ 6.000 (.2362) 5.992 (.2359)	2.5 (1.0)	7.9 (.31)	25.4 (1.00) 24.4 (.96)	50.8 (2.00) Max

Model	"K"	"L"	"M"	"N"
MPM401***6***	#6-32UNC-2B∇ 250 (6.35)(4)EQ SPD AS SHOWN ON ∅ 1.531 (38.89)B.C.	3.83(97.3)Max	∅ 1.000(25.40) .998(25.35)	□ 1.575(40.00)
MPM401***7***	M3 X .5∇ 6.35(250)(4)EQ SPD AS SHOWN ON ∅ 46.00 (1.811)B.C.	97.3(3.83)Max	∅ 30.00(1.181) 29.79(1.173)	□ 40.00(1.575)
MPM402***6***	#6-32UNC-2B∇ 250 (6.35)(4)EQ SPD AS SHOWN ON ∅ 1.531 (38.89)B.C.	4.33(110.0)Max	∅ 1.000(25.40) .998(25.35)	□ 1.575(40.00)
MPM402***7***	M3 X .5∇ 6.35(250)(4)EQ SPD AS SHOWN ON ∅ 46.00 (1.811)B.C.	110.0(4.33)Max	∅ 30.00(1.181) 29.79(1.173)	□ 40.00(1.575)
MPM403***6***	#6-32UNC-2B∇ 250 (6.35)(4)EQ SPD AS SHOWN ON ∅ 1.531 (38.89)B.C.	4.83(122.7)Max	∅ 1.000(25.40) .998(25.35)	□ 1.575(40.00)
MPM403***7***	M3 X .5∇ 6.35(250)(4)EQ SPD AS SHOWN ON ∅ 46.00 (1.811)B.C.	122.7(4.83)Max	∅ 30.00(1.181) 29.79(1.173)	□ 40.00(1.575)
MPM404***6***	#6-32UNC-2B∇ 250 (6.35)(4)EQ SPD AS SHOWN ON ∅ 1.531 (38.89)B.C.	5.33(135.4)Max	∅ 1.000(25.40) .998(25.35)	□ 1.575(40.00)
MPM404***7***	M3 X .5∇ 6.35(250)(4)EQ SPD AS SHOWN ON ∅ 46.00 (1.811)B.C.	135.4(5.33)Max	∅ 30.00(1.181) 29.79(1.173)	□ 40.00(1.575)

English = 6 Units: in (mm)  
 Metric = 7 Units: in (mm)

**Custom Designed Servo Motors For Your Specific Application. Call 1-800-358-9070 Today.**

**1 1/2" Motor with Resolver Feedback**

**Option 1**

**Motor Therm Resolver Connector 270-00024 (PT02E-14-18P(027))**

Pin	Function
A	φR
B	φS
C	φT
D	PE GND
U	THERM
N	THERM
H	SIN
G	COS GND
S	COS
F	SIN GND
R	REF GND
E	REF
J	RES SHLD
K	-
L	-
M	-
P	-
T	-

**Option 4**

**Connection Chart**

Function	Wire Color
φR	RED
φS	BLACK
φT	BLUE
PE GND	GRN/YEL
THERM	WHITE
THERM	WHITE
SIN	YELLOW
COS GND	BLACK
COS	RED
SIN GND	BLUE
REF GND	YEL/WHT
REF	RED/WHT
RES SHLD	GRN/YEL

Option 2 and 3-Not Available  
 Brake Option-Consult Factory  
 Encoder Option-Consult Factory

## 2" Frame Brushless Servo Motors



### Motor Data (Sine)

Motor Parameters		Units	661ASF****	661BSF****	662ASF****	662BSF****
Horsepower	Hp Rated	Hp	.15	.09	.22	.16
Kilowatts	KW Rated	KW	.11	.07	.16	.12
Max. Operating Speed	N Max	RPM	6000	3000	5000	3000
Speed @ Rated Torque	N Rated	RPM	4000	2500	4000	2500
*Continuous Rated Torque @ Rated Speed		IN-LBS[Nm]	2.3[.26]	2.3[.26]	3.4[.38]	4.0[.45]
*Continuous Stall Torque		IN-LBS[Nm]	2.6[.29]	2.6[.29]	5.0[.56]	5.0[.56]
Continuous Line Current		AMPS(RMS/φ)	2.1	1.1	1.8	1.1
Peak Torque	Tpk	IN-LBS[Nm]	7.8[0.9]	7.8[0.9]	15.1[1.7]	15.1[1.7]
Peak Current		AMPS(RMS/φ)	6.9	3.5	5.4	3.3
Max. Theoretical Accel.		RAD/SEC <sup>2</sup>	118.182	118.182	155.670	155.670
Torque Sensitivity	Kt	IN-LBS/AMP(RMS/φ) [Nm/AMP(RMS/φ)]	1.5[.16]	2.8[.32]	2.8[.32]	4.5[.51]
Back EMF (Line to Line)	±10%	Vrms/Krpm	9.2	18.0	17.8	28.3
D.C.Resistance (P-P)	±10%	OHMS	6.9	31.9	8.4	18.5
Inductance (P-P)	±10%	MILLIHENRIES	7.7	29.4	11.6	26.4
Rotor Inertia	Jm	IN-LBS-SEC <sup>2</sup> [Kg-M <sup>2</sup> ]	.000066[.0000075]	.000066[.0000075]	.000097[.0000109]	.000097[.0000109]
Static Friction	Tf	IN-LBS[Nm]	.35[.04]	.35[.04]	0.5[0.06]	0.5[0.06]
Motor Weight		LBS[Kg]	2.2[1.0]	2.2[1.0]	2.8[1.3]	2.8[1.3]
Line Voltage		VAC	110	110	110	110

Motor Parameters		Units	663ASF****	663BSF****	664ASF****	664BSF****
Horsepower	Hp Rated	Hp	.36	.19	.48	.34
Kilowatts	KW Rated	KW	.27	.14	.35	.26
Max. Operating Speed	N Max	RPM	5500	3300	6000	3600
Speed @ Rated Torque	N Rated	RPM	4500	2000	5000	3000
*Continuous Rated Torque @ Rated Speed		IN-LBS[Nm]	5.0[.56]	6.0[.68]	6.0[0.68]	8.0[.90]
*Continuous Stall Torque		IN-LBS[Nm]	7.5[.85]	7.5[.85]	10.0[1.13]	10.0[1.13]
Continuous Line Current		AMPS(RMS/φ)	2.7	1.4	3.5	2.2
Peak Torque	Tpk	IN-LBS[Nm]	22.5[2.54]	22.5[2.54]	30.0[3.4]	30.0[3.4]
Peak Current		AMPS(RMS/φ)	8.0	4.9	10.6	6.6
Max. Theoretical Accel.		RAD/SEC <sup>2</sup>	175,781	175,781	188,679	188,679
Torque Sensitivity	Kt	IN-LBS/AMP(RMS/φ) [Nm/AMP(RMS/φ)]	2.8[.32]	4.5[.51]	2.8[.32]	4.5[.51]
Back EMF (Line to Line)	±10%	Vrms/Krpm	17.8	28.3	17.8	28.3
D.C.Resistance (P-P)	±10%	OHMS	5.2	14.4	3.1	7.0
Inductance (P-P)	±10%	MILLIHENRIES	7.0	17.9	5.1	11.0
Rotor Inertia	Jm	IN-LBS-SEC <sup>2</sup> [Kg-M <sup>2</sup> ]	.000128[.0000145]	.000128[.0000145]	.000159[.0000179]	.000159[.0000179]
Static Friction	Tf	IN-LBS[Nm]	.65[.073]	.65[.073]	0.8[0.09]	0.8[0.09]
Motor Weight		LBS[Kg]	3.2[1.5]	3.2[1.5]	3.8[1.7]	3.8[1.7]
Line Voltage		VAC	110	110	110	110

#### Brake Info:

Min. Holding Torque: 10IN-LBS  
 Input Voltage: 24VDC  
 Current: .21AMPS  
 Inertia: .000029IN-LB-SEC<sup>2</sup>  
 Weight Adder: .8LBS

\*25° C Ambient with a maximum case temperature of 100° C on motor. Motor mounted on a 10" x 10" x 1/4" aluminum heatsink. Thermostat in stator windings will open if winding temperature exceeds 155° C for an approximate +10% headroom in the continuous torque rating before thermostat opens.

#### Mechanical Notes:

1. Axial Load: 15 LBS. Max.
  2. Radial Load: 20 LBS. Max. @ 1" from face
  3. Motor sealed to IP65
- Please note: MPM66\*BTG\*\*\*\*are available

Custom Designed Servo Motors For Your Specific Application. Call 1-800-358-9070 Today.

**Motor Data (Trap)**

Motor Parameters		Units	661ATF****	661BTF****	662ATF****	662BTF****
Horsepower	Hp Rated	Hp	.15	.09	.22	.16
Kilowatts	KW Rated	KW	.11	.07	.16	.12
Max. Operating Speed	N Max	RPM	6000	3000	5000	3000
Speed @ Rated Torque	N Rated	RPM	4000	2500	4000	2500
*Continuous Rated Torque @ Rated Speed		IN-LBS[Nm]	2.3[.26]	2.3[.26]	3.4[.38]	4.0[.45]
*Continuous Stall Torque		IN-LBS[Nm]	2.6[.29]	2.6[.29]	5.0[.56]	5.0[.56]
Continuous Line Current		AMPS	3.0	1.53	2.5	1.6
Peak Torque	Tpk	IN-LBS[Nm]	7.8[0.9]	7.8[0.9]	15.1[1.7]	15.1[1.7]
Peak Current		AMPS	9.7	5.0	7.6	4.7
Max. Theoretical Accel.		RAD/SEC <sup>2</sup>	118,182	118,182	155,670	155,670
Torque Sensitivity	Kt	IN-LBS/AMP[Nm/AMP]	1.03[.12]	2.0[.23]	2.0[.23]	3.2[.36]
Back EMF (Line to Line)	±10%	Vrms/Krpm	9.2	18.0	17.8	28.3
D.C.Resistance (P-P)	±10%	OHMS	6.9	31.9	8.4	18.5
Inductance (P-P)	±10%	MILLIHENRIES	7.7	29.4	11.6	26.4
Rotor Inertia	Jm	IN-LBS-SEC <sup>2</sup> [Kg-M <sup>2</sup> ]	.000066[.0000075]	.000066[.0000075]	.000097[.0000109]	.000097[.0000109]
Static Friction	Tf	IN-LBS[Nm]	.35[.04]	.35[.04]	0.5[.06]	0.5[.06]
Motor Weight		LBS[Kg]	2.2[1.0]	2.2[1.0]	2.8[1.3]	2.8[1.3]
Line Voltage		VAC	110	110	110	110

Motor Parameters		Units	663ATF****	663BTF****	664ATF****	664BTF****
Horsepower	Hp Rated	Hp	.36	.19	.48	.34
Kilowatts	KW Rated	KW	.27	.14	.35	.26
Max. Operating Speed	N Max	RPM	5500	3300	6000	3600
Speed @ Rated Torque	N Rated	RPM	4500	2000	5000	2700
*Continuous Rated Torque @ Rated Speed		IN-LBS[Nm]	5.0[.56]	6.0[.68]	6.0[.68]	8.0[.90]
*Continuous Stall Torque		IN-LBS[Nm]	7.5[.85]	7.5[.85]	10.0[1.13]	10.0[1.13]
Continuous Line Current		AMPS	3.8	2.0	5.0	3.1
Peak Torque	Tpk	IN-LBS[Nm]	22.5[2.54]	22.5[2.54]	30.0[3.4]	30.0[3.4]
Peak Current		AMPS	11.3	7.0	15.0	9.4
Max. Theoretical Accel.		RAD/SEC <sup>2</sup>	175,781	175,781	188,679	188,679
Torque Sensitivity	Kt	IN-LBS/AMP[Nm/AMP]	2.0[.23]	3.2[.36]	2.0[.23]	3.2[.36]
Back EMF (Line to Line)	±10%	Vrms/Krpm	17.8	28.3	17.8	28.3
D.C.Resistance (P-P)	±10%	OHMS	5.2	14.4	3.1	7.0
Inductance (P-P)	±10%	MILLIHENRIES	7.0	17.9	5.1	11.0
Rotor Inertia	Jm	IN-LBS-SEC <sup>2</sup> [Kg-M <sup>2</sup> ]	.000128[.0000145]	.000128[.0000145]	.000159[.0000179]	.000159[.0000179]
Static Friction	Tf	IN-LBS[Nm]	.65[.073]	.65[.073]	0.8[.09]	0.8[.09]
Motor Weight		LBS[Kg]	3.2[1.5]	3.2[1.5]	3.8[1.7]	3.8[1.7]
Line Voltage		VAC	110	110	110	110

**Brake Info:**

Min. Holding Torque: 10IN-LBS  
 Input Voltage: 24VDC  
 Current : .21 AMPS  
 Inertia: .000025IN-LB-SEC<sup>2</sup>  
 Weight Adder: .8 LBS

\*25° C Ambient with a maximum case temperature of 100° C on motor. Motor mounted on a 10" x 10" x 1/4" aluminum heatsink. Thermostat in stator windings will open if winding temperature exceeds 155° C for an approximate +10% headroom in the continuous torque rating before thermostat opens.

**Mechanical Notes:**

1. Axial Load: 15 LBS. Max.
  2. Radial Load: 20 LBS. Max. @ 1" from face
  3. Motor sealed to IP65
- Please note: MPM66\*BTG\*\*\*\*are available

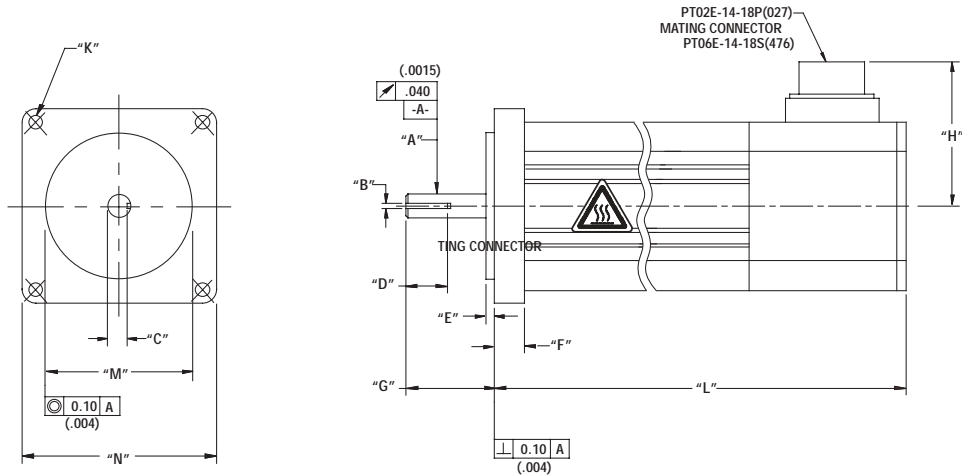

**2" (66) English and Metric Connectorized Termination-Option 1 Motors**

Model	"A"	"B"	"C"	"D"	"E"	"F"
MPM662***6***	∅ 2500 (6.350) 2495 (6.337)	NA	NA	NA	.06 (1.6)	.46 (11.7)
MPM662***7***	∅ 8.000 (.3150) 7.991 (.3146)	2.000 (.0787) 1.971 (.0776)	6.68 (.263)	14.00 (.551) Min	3.0 (.12)	10.2 (.40)
MPM664***6***	∅ 2500 (6.350) 2495 (6.337)	NA	NA	NA	.06 (1.6)	.46 (11.7)
MPM664***7***	∅ 8.000 (.3150) 7.991 (.3146)	2.000 (.0787) 1.971 (.0776)	6.68 (.263)	14.00 (.551) Min	3.0 (.12)	10.2 (.40)

Model	"G"	"H"	"K"	"L"	"L" w/ Brake	"M"	"N"
MPM662***6***	.83 (21.1) .79 (20.1)	2.0 (51) Max	205(5.21) THRU (4) EQ SPD AS SHOWN ON Ø2.625 (66.68) B.C.	5.55(140.9) Max	6.75(171.5)	∅ 1.502(38.15) 1.498(38.05)	□ 2.25(57.2)
MPM662***7***	30.5 (1.20) 29.5 (1.16)	51 (2.0) Max	∅5.00(.197) THRU (4) EQ SPD AS SHOWN ON Ø80.00 (3.150) B.C.	139.5 (5.49) Max	169.9 (6.69)	∅ 50.000 (1.9685) 49.975 (1.9675)	□ 66.00 (2.598)
MPM664***6***	.83 (21.1) .79 (20.1)	2.0 (51) Max	.205(5.21) THRU (4) EQ SPD AS SHOWN ON Ø2.625 (66.68) B.C.	6.75(171.5) Max	7.95(201.9)	∅ 1.502(38.15) 1.498(38.05)	□ 2.25 (57.2)
MPM664***7***	30.5 (1.20) 29.5 (1.16)	51 (2.0) Max	∅5.00(.197) THRU (4) EQ SPD AS SHOWN ON Ø80.00 (3.150) B.C.	169.6 (6.69) Max	200.4 (7.89)	∅ 50.000 (1.9685) 49.975 (1.9675)	□ 66.00 (2.598)



English = 6 (NEMA 23) Units: in (mm)  
 Metric = 7 Units: mm (in)

Custom Designed Servo Motors For Your Specific Application. Call 1-800-358-9070 Today.

**2" Motor with Resolver Feedback**

**Option 1**



**Motor Connector 270-00024 (PT02E-14-18P(027))**

Pin	Function
A	$\phi$ R
B	$\phi$ S
C	$\phi$ T
D	PE GND
U	THERM
N	THERM
H	SIN
G	COS GND
S	COS
F	SIN GND
R	REF GND
E	REF
J	RES SHLD
*K	BRK (+) 
*L	BRK (-) 
*M	BRK SHLD
P	-
T	-

\*USE ONLY WITH BRAKE OPTION

**Option 2**

**Motor Connector 270-00256 (BEGA089NN0000009000)**

Pin	Function
1	$\phi$ R (U1)
2	PE GND
3	$\phi$ T (W1)
4	$\phi$ S (V1)
*A	BRK (+) 
*B	BRK (-) 
C	THERM
D	THERM

\*USE ONLY WITH BRAKE OPTION



**Resolver Connector 270-00257 (AEGA052NN00000013000)**

Pin	Function
1	-
2	REF (R1)
3	REF GND (R2)
4	COS GND (S1)
5	COS (S3)
6	SIN (S2)
7	SIN GND (S4)
8	-
9	-
10	-
11	-
12	-

**2" Motor with Encoder Feedback**

**Option 1**



**Motor Brake Encoder Connector 270-00219 (PT02E-16-23P(027))**

Pin	Function
A	φR
B	φS
C	φT
D	PE GND
T	GND
E	+5VDC
F	CH A
U	CH A\
G	CH B
V	CH B\
H	CH Z
W	CH Z\
J	CH U
K	CH U\
X	CH V
L	CH V\
Y	CH W
M	CH W\
N	GND/CABLE
S	THERM
R	THERM
*P	BRK (+) 
*Z	BRK (-) 

\*USE ONLY WITH BRAKE OPTION

**Option 2**

**Motor Connector 270-00256 (BEGA089NN0000009000)**

Pin	Function
1	φR
2	φS
3	φT
4	φT
*A	BRK (+) 
*B	BRK (-) 
C	THERM
D	THERM

\*USE ONLY WITH BRAKE OPTION

**Encoder Connector 270-00257 (AEGA052NN00000013000)**

Pin	Function
1	GND (0V)
2	CH A\ (A)
3	CH A (A\)
4	CH B (B)
5	CH B\ (B\)
6	CH Z (Z)
7	CH Z\ (Z\)
8	+5V (+5V)
9	-
10	CH U (RLGU)
11	CH V (RLGV)
12	CH W (RLGW)



Custom Designed Servo Motors For Your Specific Application. Call 1-800-358-9070 Today.

## 2 3/4" Frame Brushless Servo Motors



### Motor Data (Sine)

Motor Parameters		Units	721ASF****	721BSG****	721CSG****	722ASF****	722BSG****	722CSG****
Horsepower	Hp Rated	Hp	0.41	0.41	0.24	0.74	0.74	0.47
Kilowatts	KW Rated	KW	0.31	0.31	0.18	0.55	0.55	0.35
Max. Operating Speed	N Max	RPM	6800	6800	4000	7000	7000	4000
Speed @ Rated Torque	N Rated	RPM	5500	5500	3000	5000	5000	3000
*Continuous Rated Torque @ Rated Speed		IN-LBS[Nm]	4.7[0.54]	4.7[0.54]	5.1[0.58]	9.4[1.06]	9.4[1.06]	10.0[1.13]
*Continuous Stall Torque		IN-LBS[Nm]	5.8[0.66]	5.8[0.66]	5.8[0.66]	11.3[1.28]	11.3[1.28]	11.3[1.28]
Continuous Line Current		AMPS/(RMS/φ)	2.7	1.4	0.7	5.0	2.7	1.4
Peak Torque	Tpk	IN-LBS[Nm]	17.0[2.0]	17.0[2.0]	17.0[2.0]	34.0[3.8]	34.0[3.8]	34.0[3.8]
Peak Current		AMPS/(RMS/φ)	8.1	4.2	2.1	15.0	8.2	4.2
Max. Theoretical Accel.		RAD/SEC <sup>2</sup>	110,000	110,000	110,000	130,000	130,000	130,000
Torque Sensitivity	Kt	IN-LBS/AMP/(RMS/φ)[Nm/AMP/(RMS/φ)]	2.14[0.241]	4.12[0.465]	8.10[0.916]	2.26[0.255]	4.12[0.465]	8.12[0.917]
Back EMF (Line to Line)	±10%	Vrms/Krpm	13.4	25.9	51.0	14.2	25.9	51.1
D.C. Resistance (P-P)	±10%	OHMS	3.1	11	45	1.1	3.7	15
Inductance (P-P)	±10%	MILLIHENRIES	4.9	17	70	2.3	7.3	29
Rotor Inertia	Jm	IN-LBS-SEC <sup>2</sup> [Kg-M <sup>2</sup> ]	.00015[.000017]	.00015[.000017]	.00015[.000017]	.00027[.000031]	.00027[.000031]	.00027[.000031]
Static Friction	Tf	IN-LBS[Nm]	0.6[0.07]	0.6[0.07]	0.6[0.07]	0.8[0.09]	0.8[0.09]	0.8[0.09]
Motor Weight		LBS[Kg]	3.5[1.59]	3.5[1.59]	3.5[1.59]	4.4[2.00]	4.4[2.00]	4.4[2.00]
Line Voltage		VAC	110	230	230	110	230	230

**Motor Data (Trap)**

Motor Parameters		Units	721ATF****	721BTG****	721CTG****	722ATF****	722BTG****	722CTG****
Horsepower	Hp Rated	Hp	0.41	0.41	0.24	0.74	0.74	0.47
Kilowatts	KW Rated	KW	0.31	0.31	0.18	0.55	0.55	0.35
Max. Operating Speed	N Max	RPM	6800	6800	4000	7000	7000	4000
Speed @ Rated Torque	N Rated	RPM	5500	5500	3000	5000	5000	3000
*Continuous Rated Torque @ Rated Speed		IN-LBS[Nm]	4.7[0.54]	4.7[0.54]	5.1[0.58]	9.4[1.06]	9.4[1.06]	10.0[1.13]
*Continuous Stall Torque		IN-LBS[Nm]	5.8[0.66]	5.8[0.66]	5.8[0.66]	11.3[1.28]	11.3[1.28]	11.3[1.28]
Continuous Line Current		AMPS	3.8	2.0	1.0	7.1	3.9	2.0
Peak Torque	Tpk	IN-LBS[Nm]	17.0[2.0]	17.0[2.0]	17.0[2.0]	34.0[3.8]	34.0[3.8]	34.0[3.8]
Peak Current		AMPS	12.0	6.0	3.0	21.0	12.0	5.9
Max. Theoretical Accel.		RAD/SEC <sup>2</sup>	110,000	110,000	110,000	130,000	130,000	130,000
Torque Sensitivity	Kt	IN-LBS/AMP[Nm/AMP]	1.51[0.171]	2.91[0.329]	5.73[0.647]	1.60[0.180]	2.91[0.329]	5.74[0.649]
Back EMF (Line to Line)	±10%	Vrms/Krpm	13.4	25.9	51.0	14.2	25.9	51.1
D.C.Resistance (P-P)	±10%	OHMS	3.1	11	45	1.1	3.7	15
Inductance (P-P)	±10%	MILLIHENRIES	4.9	17	70	2.3	7.3	29
Rotor Inertia	Jm	IN-LBS-SEC <sup>2</sup> [Kg-M <sup>2</sup> ]	.00015[.000017]	.00015[.000017]	.00015[.000017]	.00027[.000031]	.00027[.000031]	.00027[.000031]
Static Friction	Tf	IN-LBS[Nm]	0.6[0.007]	0.6[0.007]	0.6[0.007]	0.8[0.09]	0.8[0.09]	0.8[0.09]
Motor Weight		LBS[Kg]	3.5[1.59]	3.5[1.59]	3.5[1.59]	4.4[2.00]	4.4[2.00]	4.4[2.00]
Line Voltage		VAC	110	230	230	110	230	230

Motor Parameters		Units	723ATF****	723BTG****	723CTG****	724ATF****	724BTG****	724CTG****
Horsepower	Hp Rated	Hp	0.91	0.91	0.63	1.3	1.3	0.79
Kilowatts	KW Rated	KW	0.68	0.68	0.47	0.93	0.93	0.58
Max. Operating Speed	N Max	RPM	6300	6300	4000	6000	6000	4000
Speed @ Rated Torque	N Rated	RPM	4500	4500	3000	5000	5000	3000
*Continuous Rated Torque @ Rated Speed		IN-LBS[Nm]	12.8[1.44]	12.8[1.44]	13.3[1.50]	15.8[1.79]	15.8[1.79]	16.6[1.88]
*Continuous Stall Torque		IN-LBS[Nm]	15.0[1.69]	15.0[1.69]	15.0[1.69]	18.8[2.12]	18.8[2.12]	18.8[2.12]
Continuous Line Current		AMPS	9.8	5.1	2.6	13.0	6.2	3.2
Peak Torque	Tpk	IN-LBS[Nm]	45.0[5.1]	45.0[5.1]	45.0[5.1]	56.0[6.4]	56.0[6.4]	56.0[6.4]
Peak Current		AMPS	29.0	15.0	7.8	38.0	19.0	9.7
Max. Theoretical Accel.		RAD/SEC <sup>2</sup>	120,000	120,000	120,000	110,000	110,000	110,000
Torque Sensitivity	Kt	IN-LBS/AMP[Nm/AMP]	1.53[0.173]	2.96[0.334]	5.78[0.652]	1.49[0.168]	3.01[0.340]	5.82[0.658]
Back EMF (Line to Line)	±10%	Vrms/Krpm	13.7	26.3	51.4	13.2	26.8	51.8
D.C.Resistance (P-P)	±10%	OHMS	0.58	2.2	7.8	0.39	1.5	5.5
Inductance (P-P)	±10%	MILLIHENRIES	1.3	4.9	18	0.9	3.6	13
Rotor Inertia	Jm	IN-LBS-SEC <sup>2</sup> [Kg-M <sup>2</sup> ]	.00038[.000043]	.00038[.000043]	.00038[.000043]	.00049[.000055]	.00049[.000055]	.00049[.000055]
Static Friction	Tf	IN-LBS[Nm]	1.0[0.11]	1.0[0.11]	1.0[0.11]	1.2[0.14]	1.2[0.14]	1.2[0.14]
Motor Weight		LBS[Kg]	5.3[2.40]	5.3[2.40]	5.3[2.40]	6.2[2.81]	6.2[2.81]	6.2[2.81]
Line Voltage		VAC	110	230	230	110	230	230

**Brake Info:**

Min. Holding Torque: 24IN-LBS  
 Input Voltage: 24VDC  
 Current: .6 AMPS  
 Inertia: .00007IN-LB-SEC<sup>2</sup>  
 Weight Adder: 1.0LB

\*25° C Ambient with a maximum case temperature of 85° C on motor. Motor mounted on a 12" x 12" x 1/2" aluminum heatsink. Thermostat in stator windings will open if winding temperature exceeds 155° C for an approximate +10% headroom in the continuous torque rating before thermostat opens.

**Mechanical Notes:**

1. Axial Load: 20 LBS. Max.
2. Radial Load: 35 LBS. Max. @ 1" from face
3. Motor sealed to IP65

Custom Designed Servo Motors For Your Specific Application. Call 1-800-358-9070 Today.

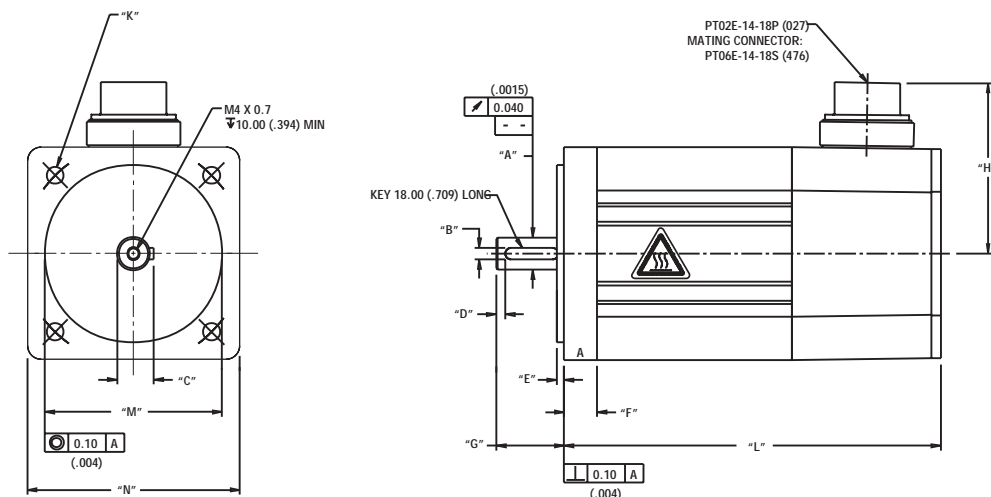

**2 3/4" (72) Metric Connectorized Termination-Option 1 Motors**

Model	"A"	"B"	"C"	"D"	"E"	"F"	"G"
MPM721***7*1*	∅ 11.012(.4335) 11.001(.4331)	3.988(.1570) 3.958(.1558)	12.42(.489)	3.00(.118)	2.5(.10)	11.2(.44)	23.0(.91) 22.5(.89)
MPM722***7*1*	∅ 11.012(.4335) 11.001(.4331)	3.988(.1570) 3.958(.1558)	12.42(.489)	3.00(.118)	2.5(.10)	11.2(.44)	23.0(.91) 22.5(.89)
MPM723***7*1*	∅ 11.012(.4335) 11.001(.4331)	3.988(.1570) 3.958(.1558)	12.42(.489)	3.00(.118)	2.5(.10)	11.2(.44)	23.0(.91) 22.5(.89)
MPM724***7*1*	∅ 11.012(.4335) 11.001(.4331)	3.988(.1570) 3.958(.1558)	12.42(.489)	3.00(.118)	2.5(.10)	11.2(.44)	23.0(.91) 22.5(.89)

Model	"H"	"K"	"L"	"L" w/ Brake	"M"	"N"
MPM721***7*1*	58 (2.3) Max	∅5.79(.228)THRU (4)EQ SPD AS SHOWN ON ∅75.01(2.953)B.C.	128.1(5.05)Max	166.3 (6.55)Max	∅ 60.012(2.3627) 59.993(2.3619)	□ 72.0(2.84)
MPM722***7*1*	58 (2.3) Max	∅5.79(.228)THRU (4)EQ SPD AS SHOWN ON ∅75.01(2.953)B.C.	147.3(5.80)Max	185.4 (7.30)Max	∅ 60.012(2.3627) 59.993(2.3619)	□ 72.0(2.84)
MPM723***7*1*	58 (2.3) Max	∅5.79(.228)THRU (4)EQ SPD AS SHOWN ON ∅75.01(2.953)B.C.	166.4(6.55)Max	204.5 (8.05)Max	∅ 60.012(2.3627) 59.993(2.3619)	□ 72.0(2.84)
MPM724***7*1*	58 (2.3) Max	∅5.79(.228)THRU (4)EQ SPD AS SHOWN ON ∅75.01(2.953)B.C.	185.4(7.30)Max	223.5 (8.80)Max	∅ 60.012(2.3627) 59.993(2.3619)	□ 72.0(2.84)

Metric = 7 Units: mm(in)  
 Option 6 Mount- Not Available

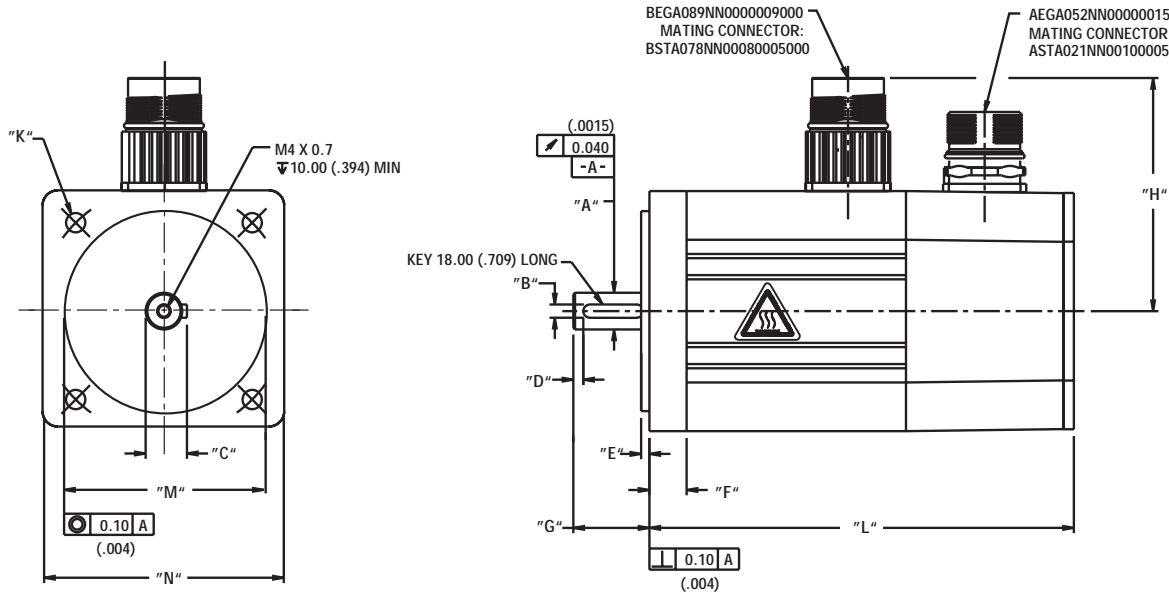

**2 3/4" (72) Metric Intercon Termination-Option 2 Motors**

Model	"A"	"B"	"C"	"D"	"E"	"F"	"G"
MPM721***7*2*	∅ 11.012(.4335) 11.001(.4331)	3.988(.1570) 3.958(.1558)	12.42(.489)	3.00(.118)	2.5(.10)	11.2(.44)	23.0(.91) 22.5(.89)
MPM722***7*2*	∅ 11.012(.4335) 11.001(.4331)	3.988(.1570) 3.958(.1558)	12.42(.489)	3.00(.118)	2.5(.10)	11.2(.44)	23.0(.91) 22.5(.89)
MPM723***7*2*	∅ 11.012(.4335) 11.001(.4331)	3.988(.1570) 3.958(.1558)	12.42(.489)	3.00(.118)	2.5(.10)	11.2(.44)	23.0(.91) 22.5(.89)
MPM724***7*2*	∅ 11.012(.4335) 11.001(.4331)	3.988(.1570) 3.958(.1558)	12.42(.489)	3.00(.118)	2.5(.10)	11.2(.44)	23.0(.91) 22.5(.89)

Model	"H"	"K"	"L"	"L" w/ Brake	"M"	"N"
MPM721***7*2*	70(2.8)Max	∅5.79(.228)THRU (4)EQ SPD AS SHOWN ON ∅75.01(2.953) B.C.	128.1(5.05)Max	166.4(6.55)	∅ 60.012(2.3627) 59.993(2.3619)	□ 72.0(2.84)
MPM722***7*2*	70(2.8)Max	∅5.79(.228)THRU (4)EQ SPD AS SHOWN ON ∅75.01(2.953) B.C.	147.3(5.80)Max	185.4(7.30)	∅ 60.012(2.3627) 59.993(2.3619)	□ 72.0(2.84)
MPM723***7*2*	70(2.8)Max	∅5.79(.228)THRU (4)EQ SPD AS SHOWN ON ∅75.01(2.953) B.C.	166.4(6.55)Max	204.5(8.05)	∅ 60.012(2.3627) 59.993(2.3619)	□ 72.0(2.84)
MPM724***7*2*	70(2.8)Max	∅5.79(.228)THRU (4)EQ SPD AS SHOWN ON ∅75.01(2.953) B.C.	185.4(7.30)Max	223.5(8.80)	∅ 60.012(2.3627) 59.993(2.3619)	□ 72.0(2.84)



Metric = 7 Units: mm (in)  
 Option 6 Mount-Not Available

**Custom Designed Servo Motors For Your Specific Application. Call 1-800-358-9070 Today.**

**2 3/4" Motor with Resolver Feedback**

**Option 1**

**Motor Therm Resolver Connector 270-00024(PT02E-14-18P(027))**



Pin	Function
A	φR
B	φS
C	φT
D	PE GND
U	THERM
N	THERM
H	SIN
G	COS GND
S	COS
F	SIN GND
R	REF GND
E	REF
J	RES SHLD
*K	BRK (+) 
*L	BRK (-) 
*M	BRK SHLD
P	-
T	-

\* USE ONLY WITH BRAKE OPTION

**Option 3-Not Available**

**Option 2**

**Motor Therm Connector 270-000256 (BEGA089NN0000009000)**

Pin	Function
1	φR (U1)
2	PE GND
3	φT (W1)
4	φS (V1)
*A	BRK (+) 
*B	BRK (-) 
C	THERM
D	THERM

\* USE ONLY WITH BRAKE OPTION

**Resolver Connector 270-00257 (AEGA052NN00000013000)**

Pin	Function
1	-
2	REF (R1)
3	REF GND (R2)
4	COS GND (S1)
5	COS (S3)
6	SIN (S2)
7	SIN GND (S4)
8	-
9	-
10	-
11	-
12	-

**2 3/4" Motor with Encoder Feedback**

**Option 1**

**Motor Encoder Therm Connector 270-00219 (PT02E-16-23P(027))**



Pin	Function
A	φR
B	φS
C	φT
D	PE GND
T	GROUND
E	+5VDC
F	CH A
U	CH A\
G	CH B
V	CH B\
H	CH Z
W	CH Z\
J	CH U
K	CH U\
X	CH V
L	CH V\
Y	CH W
M	CH W\
N	GND/CABLE
S	THERM
R	THERM
*P	BRK (+) 
*Z	BRK (-) 

\* USE ONLY WITH BRAKE OPTION

**Option 3-Not Available**

**Option 2**

**Motor Therm Connector 270-000256 (BEGA089NN000009000)**

Pin	Function
1	φR (U1)
2	PE GND
3	φS (W1)
4	φT (V1)
*A	BRK (+) 
*B	BRK (-) 
C	THERM
D	THERM

\* USE ONLY WITH BRAKE OPTION

**Encoder Connector 270-00257 (AEGA052NN0000013000)**

Pin	Function
1	GND (0V)
2	CH A(A)
3	CH A(A)
4	CH B(B)
5	CH B(B)
6	CH Z(Z)
7	CH Z(Z)
8	+5V(+5V)
9	-
10	CH U(RLG U)
11	CH V(RLG V)
12	CH W(RLG W)

Custom Designed Servo Motors For Your Specific Application. Call 1-800-358-9070 Today.

# 3" Frame Brushless Servo Motors



## Motor Data (Sine)

Motor Parameters		Units	891ASG****	891BSG****
Horsepower	Hp Rated	Hp	0.82	0.55
Kilowatts	KW Rated	KW	0.62	0.41
Max. Operating Speed	N Max	RPM	5000	3000
Speed @ Rated Torque	N Rated	RPM	4000	2400
*Continuous Rated Torque @ Rated Speed		IN-LBS[Nm]	13.0[1.47]	14.5[1.64]
*Continuous Stall Torque		IN-LBS[Nm]	16.0[1.81]	16.0[1.81]
Continuous Line Current		AMPS(RMS/φ)	2.7	1.3
Peak Torque	Tpk	IN-LBS[Nm]	58.8[6.64]	58.8[6.64]
Peak Current		AMPS(RMS/φ)	9.9	4.9
Max. Theoretical Accel.		RAD/SEC <sup>2</sup>	95,610	95,610
Torque Sensitivity	Kt	IN-LBS/AMP(RMS/φ)[Nm/AMP(RMS/φ)]	5.9[.67]	11.9[1.34]
Back EMF (Line to Line)	±10%	Vrms/Krpm	37.6	752
D.C.Resistance (P-P)	±10%	OHMS	3.9	15.4
Inductance (P-P)	±10%	MILLIHENRIES	10.4	39.6
Rotor Inertia	Jm	IN-LBS-SEC <sup>2</sup> [Kg-M <sup>2</sup> ]	.000615[.0000693]	.000615[.0000693]
Static Friction	Tf	IN-LBS[Nm]	0.4[0.05]	0.4[0.05]
Motor Weight		LBS[Kg]	7.8[3.5]	7.8[3.5]
Line Voltage		VAC	230	230

Motor Parameters		Units	892ASG****	892BSG****	893ASG****	893BSG****
Horsepower	Hp Rated	Hp	1.62	1.05	1.96	1.10
Kilowatts	KW Rated	KW	1.20	0.78	1.46	0.85
Max. Operating Speed	N Max	RPM	5000	3000	4100	2000
Speed @ Rated Torque	N Rated	RPM	4000	2400	3600	1500
*Continuous Rated Torque @ Rated Speed		IN-LBS[Nm]	25.5[2.9]	27.5[3.1]	34.4[3.8]	36.0[4.0]
*Continuous Stall Torque		IN-LBS[Nm]	30.0[3.4]	30.0[3.4]	39.0[4.4]	39.0[4.4]
Continuous Line Current		AMPS(RMS/φ)	5.2	2.6	4.5	2.1
Peak Torque	Tpk	IN-LBS[Nm]	105.0[11.9]	105.0[11.9]	137.0[15.5]	137.0[15.5]
Peak Current		AMPS(RMS/φ)	18.9	9.6	16.3	7.9
Max. Theoretical Accel.		RAD/SEC <sup>2</sup>	105,954	105,954	100,000	100,000
Torque Sensitivity	Kt	IN-LBS/AMP(RMS/φ)[Nm/AMP(RMS/φ)]	5.8[.66]	11.6[1.31]	8.8[.99]	17.5[1.98]
Back EMF (Line to Line)	±10%	Vrms/Krpm	36.6	73.2	55.0	1100
D.C.Resistance (P-P)	±10%	OHMS	1.5	6.0	1.9	7.7
Inductance (P-P)	±10%	MILLIHENRIES	5.1	20.2	7.5	29.1
Rotor Inertia	Jm	IN-LBS-SEC <sup>2</sup> [Kg-M <sup>2</sup> ]	.000991[.0001116]	.000991[.0001116]	.00137[.000154]	.00137[.000154]
Static Friction	Tf	IN-LBS[Nm]	0.5[0.06]	0.5[0.06]	0.6[0.07]	0.6[0.07]
Motor Weight		LBS[Kg]	10.4[4.7]	10.4[4.7]	14.0[6.0]	14.0[6.0]
Line Voltage		VAC	230	230	230	230

### Brake Info:

Min. Holding Torque: 60IN-LBS  
 Input Voltage: 24VDC  
 Current : 2.2AMPS  
 Inertia : .00015IN-LB-SEC<sup>2</sup>  
 Weight Adder: 2.2LBS

\*25° C Ambient with a maximum case temperature of 100° C on motor. Motor mounted on a 10" x 10" x 1/4" aluminum heatsink. Thermostat in stator windings will open if winding temperature exceeds 155° C. This allows +10% headroom in the continuous torque rating before thermostat opens.

#### Mechanical Notes:

1. Axial Load: 25 LBS. Max.
2. Radial Load: 40 LBS. Max. @ 1" from face
3. Motor sealed to IP65

**Motor Data (Trap)**

Motor Parameters		Units	891ATG****	891BTG****
Horsepower	Hp Rated	Hp	0.82	0.55
Kilowatts	KW Rated	KW	0.62	0.41
Max. Operating Speed	N Max	RPM	5000	3000
Speed @ Rated Torque	N Rated	RPM	4000	2400
<b>*Continuous Rated Torque @ Rated Speed</b>		IN-LBS[Nm]	13.0[1.47]	14.5[1.64]
<b>*Continuous Stall Torque</b>		IN-LBS[Nm]	16.0[1.81]	16.0[1.81]
<b>Continuous Line Current</b>		AMPS	3.8	1.9
Peak Torque	Tpk	IN-LBS[Nm]	58.8[6.64]	58.8[6.64]
<b>Peak Current</b>		AMPS	14.0	7.0
<b>Max. Theoretical Accel.</b>		RAD/SEC <sup>2</sup>	95,610	95,610
Torque Sensitivity	Kt	IN-LBS/AMP[Nm/AMP]	4.2[0.48]	8.4[0.96]
Back EMF (Line to Line)	±10%	Vrms/Krpm	37.6	75.2
D.C.Resistance (P-P)	±10%	OHMS	3.9	15.4
Inductance (P-P)	±10%	MILLIHENRIES	10.4	39.6
Rotor Inertia	Jm	IN-LBS-SEC <sup>2</sup> [Kg-M <sup>2</sup> ]	.000615[.0000693]	.000615[.0000693]
Static Friction	Tf	IN-LBS[Nm]	0.4[0.05]	0.4[0.05]
Motor Weight		LBS[Kg]	7.8[3.5]	7.8[3.5]
Line Voltage		VAC	230	230

Motor Parameters		Units	892ATG****	892BTG****	893ATG****	893BTG****
Horsepower	Hp Rated	Hp	1.62	1.05	1.96	1.10
Kilowatts	KW Rated	KW	1.20	0.78	1.46	0.85
Max. Operating Speed	N Max	RPM	5000	3000	4100	2000
Speed @ Rated Torque	N Rated	RPM	4000	2400	3600	1500
<b>*Continuous Rated Torque @ Rated Speed</b>		IN-LBS[Nm]	25.5[2.9]	27.5[3.1]	34.4[3.8]	36.0[4.0]
<b>*Continuous Stall Torque</b>		IN-LBS[Nm]	30.0[3.4]	30.0[3.4]	39.0[4.4]	39.0[4.4]
<b>Continuous Line Current</b>		AMPS	7.3	3.7	6.3	3.0
Peak Torque	Tpk	IN-LBS[Nm]	105.0[11.9]	105.0[11.9]	137.0[15.5]	137.0[15.5]
<b>Peak Current</b>		AMPS	26.8	13.6	23.1	11.1
<b>Max. Theoretical Accel.</b>		RAD/SEC <sup>2</sup>	105,954	105,954	100,000	100,000
Torque Sensitivity	Kt	IN-LBS/AMP[Nm/AMP]	4.1[0.47]	8.2[0.94]	6.2[0.7]	12.4[1.4]
Back EMF (Line to Line)	±10%	Vrms/Krpm	36.6	73.2	55.0	110.0
D.C.Resistance (P-P)	±10%	OHMS	1.5	6.0	1.9	7.7
Inductance (P-P)	±10%	MILLIHENRIES	5.1	20.2	7.5	29.1
Rotor Inertia	Jm	IN-LBS-SEC <sup>2</sup> [Kg-M <sup>2</sup> ]	.000991[.0001116]	.000991[.0001116]	.00137[.000154]	.00137[.000154]
Static Friction	Tf	IN-LBS[Nm]	0.5[0.06]	0.5[0.06]	0.6[0.07]	0.6[0.07]
Motor Weight		LBS[Kg]	10.4[4.7]	10.4[4.7]	14.0[6.0]	14.0[6.0]
Line Voltage		VAC	230	230	230	230

**Brake Info:**

Min. Holding Torque: 60IN-LBS  
 Input Voltage: 24VDC  
 Current : 2.2AMPS  
 Inertia: .00015IN-LB-SEC<sup>2</sup>  
 Weight Adder: 2.2LBS

\*25° C Ambient with a maximum case temperature of 100° C on motor. Motor mounted on a 10" x 10" x 1/4" aluminum heatsink. Thermostat in stator windings will open if winding temperature exceeds 155° C. This allows +10% headroom in the continuous torque rating before thermostat opens.

- Mechanical Notes:
1. Axial Load: 25 LBS. Max.
  2. Radial Load: 40 LBS. Max. @ 1" from face
  3. Motor sealed to IP65

**Custom Designed Servo Motors For Your Specific Application. Call 1-800-358-9070 Today.**

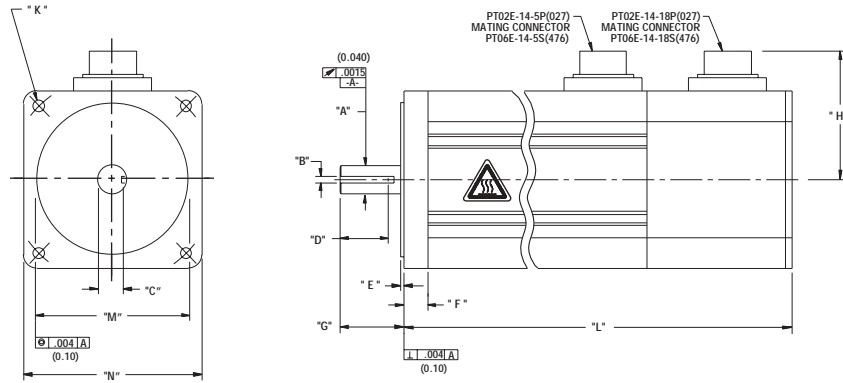

**3" (89) English and Metric Connectorized Termination-Option 1 Motors**

Model	"A"	"B"	"C"	"D"	"E"	"F"	"G"
MPM891****6***	∅ .4997 (12.692) .4993 (12.682)	.1265 (3.213) .1250 (3.175)	.420 (10.67)	.90 (22.9)Min	.06 (1.6)	.44 (11.2)	1.20 (30.5) 1.16 (29.5)
MPM891****7***	∅ 14.000 (.5512) 13.985 (.5508)	5.08 (.200) 5.00 (.197)	10.90 (.429)	20.0 (.79)Min	3.0 (.12)	11.2 (.44)	30.5 (1.20) 29.5 (1.16)
MPM892****6***	∅ .4997 (12.692) .4993 (12.682)	.1265 (3.213) .1250 (3.175)	.420 (10.67)	.90 (22.9)Min	.06 (1.6)	.44 (11.2)	1.20 (30.5) 1.16 (29.5)
MPM892****7***	∅ 14.000 (.5512) 13.985 (.5508)	5.08 (.200) 5.00 (.197)	10.90 (.429)	20.0 (.79)Min	3.0 (.12)	11.2 (.44)	30.5 (1.20) 29.5 (1.16)
MPM893****6***	∅ .4997 (12.692) .4993 (12.682)	.1265 (3.213) .1250 (3.175)	.420 (10.67)	.90 (22.9)Min	.06 (1.6)	.44 (11.2)	1.20 (30.5) 1.16 (29.5)
MPM893****7***	∅ 14.000 (.5512) 13.985 (.5508)	5.08 (.200) 5.00 (.197)	10.90 (.429)	20.0 (.79)Min	3.0 (.12)	11.2 (.44)	30.5 (1.20) 29.5 (1.16)

Model	"H"	"K"	"L"	"L" w/ Brake	"M"	"N"
MPM891****6***	2.5 (64.0)Max	∅.223 (5.66)THRU (4)EQ SPD AS SHOWN ON ∅3.875 (98.43)B.C.	7.24 (183.9)Max	8.74 (222.0) Max	∅ 2.877 (73.08) 2.873 (72.97)	□ 3.31 (84.1)
MPM891****7***	64.0 (2.5)Max	∅7.00 (.276)THRU (4)EQ SPD AS SHOWN ON ∅100.00 (3.937)B.C.	183.9 (7.24)Max	222.0 (8.74) Max	∅ 80.00 (3.150) 79.98 (3.149)	□ 89.0 (3.50)
MPM892****6***	2.5 (64.0)Max	∅.223 (5.66)THRU (4)EQ SPD AS SHOWN ON ∅3.875 (98.43)B.C.	8.74 (222.0)Max	10.24 (260.1) Max	∅ 2.877 (73.08) 2.873 (72.97)	□ 3.31 (84.1)
MPM892****7***	64.0 (2.5)Max	∅7.00 (.276)THRU (4)EQ SPD AS SHOWN ON ∅100.00 (3.937)B.C.	222.0 (8.74)Max	260.1 (10.24) Max	∅ 80.00 (3.150) 79.98 (3.149)	□ 89.0 (3.50)
MPM893****6***	2.5 (64.0)Max	∅.223 (5.66)THRU (4)EQ SPD AS SHOWN ON ∅3.875 (98.43)B.C.	10.24 (260.1)Max	11.74 (298.2) Max	∅ 2.877 (73.08) 2.873 (72.97)	□ 3.31 (84.1)
MPM893****7***	64.0 (2.5)Max	∅7.00 (.276)THRU (4)EQ SPD AS SHOWN ON ∅100.00 (3.937)B.C.	260.1 (10.24)Max	298.2 (11.74) Max	∅ 80.00 (3.150) 79.98 (3.149)	□ 89.0 (3.50)

English = 6 (NEMA 34) Units: in (mm)  
 Metric = 7 Units: mm (in)

For Mechanical Dimensions on Termination Option 2 Consult Factory.

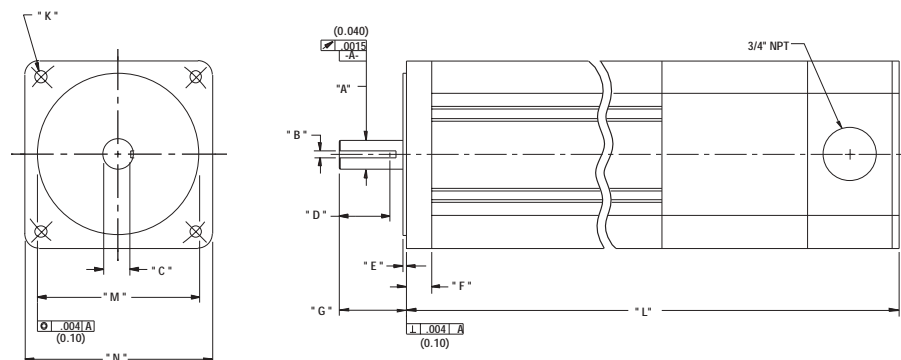

**3" (89)English and Metric NPT Termination-Option 3 Motors**

Model	"A"	"B"	"C"	"D"	"E"	"F"	"G"
<b>MPM891***6***</b>	$\varnothing$ .4997 (12.692) .4993 (12.682)	.1265 (3.213) .1250 (3.175)	.420 (10.67)	.90(22.9) Min	.06(1.6)	.44(11.2)	1.20(30.5) 1.16(29.5)
<b>MPM891***7***</b>	$\varnothing$ 14.000 (.5512) 13.985 (.5508)	5.08 (.200) 5.00 (.197)	10.90 (.429)	20.0(.79) Min	3.0 (.12)	11.2(.44)	30.5(1.20) 29.5(1.16)
<b>MPM892***6***</b>	$\varnothing$ .4997 (12.692) .4993 (12.682)	.1265 (3.213) .1250 (3.175)	.420 (10.67)	.90(22.9) Min	.06(1.6)	.44(11.2)	1.20(30.5) 1.16(29.5)
<b>MPM892***7***</b>	$\varnothing$ 14.000 (.5512) 13.985 (.5508)	5.08 (.200) 5.00 (.197)	10.90 (.429)	20.0(.79) Min	3.0 (.12)	11.2(.44)	30.5(1.20) 29.5(1.16)
<b>MPM893***6***</b>	$\varnothing$ .4997 (12.692) .4993 (12.682)	.1265 (3.213) .1250 (3.175)	.420 (10.67)	.90(22.9) Min	.06(1.6)	.44(11.2)	1.20(30.5) 1.16(29.5)
<b>MPM893***7***</b>	$\varnothing$ 14.000 (.5512) 13.985 (.5508)	5.08 (.200) 5.00 (.197)	10.90 (.429)	20.0(.79) Min	3.0 (.12)	11.2(.44)	30.5(1.20) 29.5(1.16)

Custom Designed Servo Motors For Your Specific Application. Call 1-800-358-9070 Today.

**3" Motor with Resolver Feedback**

**Option 1**

**Motor Connector 270-00026 (PT02E-14-5P(027))**

Pin	Function
A	$\phi$ R
B	$\phi$ S
C	$\phi$ T
D	PE GND
E	-

**Resolver Connector 270-00024(PT02E-14-18R(027))**

Pin	Function
U	THERM
N	THERM
H	SIN
G	COS GND
S	COS
F	SIN GND
R	REF GND
E	REF
D	RES SHLD
P	GND
A	-
B	-
C	-
J	-
K	-
L	-
M	-
T	-

**\* Option 1 with brake**

**Motor Brake Connector 270-00032 (PT02E-16-8P(027))**

Pin	Function
A	$\phi$ R
B	$\phi$ S
C	$\phi$ T
D	PE GND
E	BRK SHLD
F	BRK (+)
G	BRK (-)
H	-

**Option 2**

**Motor Connector 270-00256(BEGA089NN000009000)**

Pin	Function
1	$\phi$ R (U1)
2	PE GND
3	$\phi$ T (W1)
4	$\phi$ S (V1)
*A	BRK (+)
*B	BRK (-)
C	THERM
D	THERM

\*USE ONLY WITH BRAKE OPTION

**Resolver Connector 270-00257(AEGA052NN0000013000)**

Pin	Function
1	-
2	REF (R1)
3	REF GND (R2)
4	COS GND (S1)
5	COS (S3)
6	SIN (S2)
7	SIN GND (S4)
8	-
9	-
10	-
11	-
12	-

**Option 3**

**Connection Chart (NPT) Resolver**

Terminal	Function
R	$\phi$ R
S	$\phi$ S
T	$\phi$ T
GND	PE GND
*S11	BRK (+)
*S10	BRK (-)
S9	REF GND
S8	REF
S7	SIN
S6	COS
S5	COS GND
S4	SIN GND
S3	THERM
S2	THERM
S1	RES SHLD

\*USE ONLY WITH BRAKE OPTION

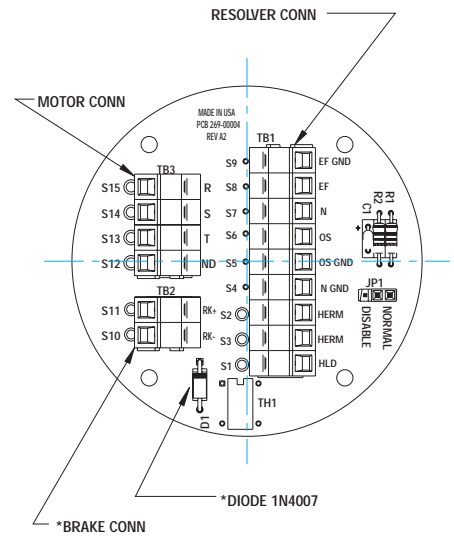

**3" Motor with Encoder Feedback**

**Option 1**

**Motor Connector 270-00026 (PT02E-14-5P(027))**

Pin	Function
A	$\phi$ R
B	$\phi$ S
C	$\phi$ T
D	PE GND
E	-

**Encoder Connector 270-00024 (PT02E-14-18P(027))**

Pin	Function
T	GND
K	+5VDC
B	CH A
C	CH A\
N	CH B
P	CH B\
M	CH Z
U	CH Z\
E	CH U
R	CH U\
F	CH V
S	CH V\
G	CH W
H	CH W\
D	GND/CABLE
A	THERM
L	THERM
J	GND

**Option 1 with brake**

**Motor Brake Connector 270-00032 (PT02E-16-8P(027))**

Pin	Function
A	$\phi$ R
B	$\phi$ S
C	$\phi$ T
D	PE GND
E	BRK SHLD
F	BRK (+)
G	BRK (-)
H	-

**Option 3-Consult Factory**

**Option 2**

**Motor Brake Connector 270-00256 (BEGA089NN00000013000)**

Pin	Function
1	$\phi$ R (U1)
2	PE GND
3	$\phi$ T (W1)
4	$\phi$ S (V1)
*A	BRK (+)
*B	BRK (-)
C	THERM
D	THERM

\*USE ONLY WITH BRAKE OPTION

**Encoder Connector 270-00257 (AEGA052NN00000013000)**

Pin	Function
1	GND (0V)
2	CH A\ (A)
3	CH A (A\)
4	CH B (B)
5	CH B\ (B\)
6	CH Z (Z)
7	CH Z\ (Z\)
8	+5V (+5V)
9	-
10	CH U (RLGU)
11	CH V (RLGV)
12	CH W (RLGW)

Custom Designed Servo Motors For Your Specific Application. Call 1-800-358-9070 Today.

# 4" Frame Brushless Servo Motors



## Motor Data (Sine)

Motor Parameters		Units	1141ASG****	1141BSG****
Horsepower	Hp Rated	Hp	2.1	1.2
Kilowatts	KW Rated	KW	1.60	.88
Max. Operating Speed	N Max	RPM	4200	2100
Speed @ Rated Torque	N Rated	RPM	3000	1500
*Continuous Rated Torque @ Rated Speed		IN-LBS[Nm]	45.0[5.1]	50.0[5.6]
*Continuous Stall Torque		IN-LBS[Nm]	54.0[6.1]	54.0[6.1]
Continuous Line Current		AMPS(RMS/φ)	6.2	3.1
Peak Torque	Tpk	IN-LBS[Nm]	189.0[21.3]	189.0[21.3]
Peak Current		AMPS(RMS/φ)	21.6	10.8
Max. Theoretical Accel.		RAD/SEC <sup>2</sup>	54,000	54,000
Torque Sensitivity	Kt	IN-LBS/AMP(RMS/φ)[Nm/AMP(RMS/φ)]	8.8[.99]	17.5[1.98]
Back EMF (Line to Line)	±10%	Vrms/Krpm	55.0	110.0
D.C.Resistance (P-P)	±10%	OHMS	0.83	3.3
Inductance (P-P)	±10%	MILLIHENRIES	6.1	24.4
Rotor Inertia	Jm	IN-LBS-SEC <sup>2</sup> [Kg-M <sup>2</sup> ]	.0035[.00039]	.0035[.00039]
Static Friction	Tf	IN-LBS[Nm]	1.0[0.11]	1.0[0.11]
Motor Weight		LBS[Kg]	19.4[8.8]	19.4[8.8]
Line Voltage		VAC	230	230

Motor Parameters		Units	1142ASG****	1142BSG****	1143ASG****	1143BSG****
Horsepower	Hp Rated	Hp	3.3	1.8	4.6	2.4
Kilowatts	KW Rated	KW	2.5	1.33	3.4	1.8
Max. Operating Speed	N Max	RPM	4200	2100	4200	2100
Speed @ Rated Torque	N Rated	RPM	3000	1500	3000	1500
*Continuous Rated Torque @ Rated Speed		IN-LBS[Nm]	69.1[7.8]	75.0[8.4]	96.8[10.9]	104.0[11.7]
*Continuous Stall Torque		IN-LBS[Nm]	83.0[9.3]	83.0[9.3]	116.2[13.1]	116.2[13.1]
Continuous Line Current		AMPS(RMS/φ)	9.5	4.7	13.2	6.6
Peak Torque	Tpk	IN-LBS[Nm]	290.5[32.7]	290.5[32.7]	406.7[45.7]	406.7[45.7]
Peak Current		AMPS(RMS/φ)	33.1	16.5	46.4	23.2
Max. Theoretical Accel.		RAD/SEC <sup>2</sup>	44,015	44,015	42,811	42,811
Torque Sensitivity	Kt	IN-LBS/AMP(RMS/φ)[Nm/AMP(RMS/φ)]	8.8[.99]	17.5[1.98]	8.8[.99]	17.5[1.98]
Back EMF (Line to Line)	±10%	Vrms/Krpm	55.0	110.0	55.0	110.0
D.C.Resistance (P-P)	±10%	OHMS	.40	1.8	.27	1.1
Inductance (P-P)	±10%	MILLIHENRIES	2.8	12.6	2.0	8.1
Rotor Inertia	Jm	IN-LBS-SEC <sup>2</sup> [Kg-M <sup>2</sup> ]	.0066[.00074]	.0066[.00074]	.0095[.00107]	.0095[.00107]
Static Friction	Tf	IN-LBS[Nm]	1.4[0.16]	1.4[0.16]	1.8[0.2]	1.8[0.2]
Motor Weight		LBS[Kg]	27.6[12.5]	27.6[12.5]	37.0[16.8]	37.0[16.8]
Line Voltage		VAC	230	230	230	230

### Brake Info

Min. Holding Torque: 240IN-LBS  
 Input Voltage: 24VDC  
 Current : .88AMPS  
 Inertia : .000412IN-LB-SEC<sup>2</sup>  
 Weight Adder: 6 LBS

\*25° C Ambient with a maximum case temperature of 100° C on motor. Motor mounted on a 12" x 12" x 1/2" aluminum heatsink. Thermostat in stator windings will open if winding temperature exceeds 155° C. This allows +10% headroom in the continuous torque rating before thermostat opens.

#### Mechanical Notes:

1. Axial Load: 50 LBS. Max.
2. Radial Load: 100 LBS. Max. @ 1" from face
3. Motor Sealed to IP65

**Motor Data (Trap)**

Motor Parameters			Units	1141ATG****	1141BTG****
Horsepower	Hp Rated	Hp		2.1	1.2
Kilowatts	KW Rated	KW		1.6	.88
Max. Operating Speed	N Max	RPM		4200	2100
Speed @ Rated Torque	N Rated	RPM		3000	1500
*Continuous Rated Torque @ Rated Speed		IN-LBS[Nm]		45.0[5.1]	50.0[5.6]
*Continuous Stall Torque		IN-LBS[Nm]		54.0[6.1]	54.0[6.1]
Continuous Line Current		AMPS		8.7	4.4
Peak Torque	Tpk	IN-LBS[Nm]		189.0[21.3]	189.0[21.3]
Peak Current		AMPS		30.5	15.3
Max. Theoretical Accel.		RAD/SEC <sup>2</sup>		54,000	54,000
Torque Sensitivity	Kt	IN-LBS/AMP[Nm/AMP]		6.2[0.71]	12.4[1.40]
Back EMF (Line to Line)	±10%	Vrms/Krpm		55.0	110.0
D.C. Resistance (P-P)	±10%	OHMS		.82	3.3
Inductance (P-P)	±10%	MILLIHENRIES		6.1	24.4
Rotor Inertia	Jm	IN-LBS-SEC <sup>2</sup> [Kg-M <sup>2</sup> ]		.0035[.00039]	.0035[.00039]
Static Friction	Tf	IN-LBS[Nm]		1.0[0.11]	1.0[0.11]
Motor Weight		LBS[Kg]		19.4[8.8]	19.4[8.8]
Line Voltage		VAC		230	230

Motor Parameters			Units	1142ATG****	1142BTG****	1143ATG****	1143BTG****
Horsepower	Hp Rated	Hp		3.3	1.8	4.6	2.4
Kilowatts	KW Rated	KW		2.5	1.3	3.4	1.8
Max. Operating Speed	N Max	RPM		4200	2100	4200	2100
Speed @ Rated Torque	N Rated	RPM		3000	1500	3000	1500
*Continuous Rated Torque @ Rated Speed		IN-LBS[Nm]		69.1[7.8]	75.0[8.4]	96.8[10.9]	104.0[11.7]
*Continuous Stall Torque		IN-LBS[Nm]		83.0[9.3]	83.0[9.3]	116.2[13.1]	116.2[13.1]
Continuous Line Current		AMPS		13.4	6.7	18.7	9.4
Peak Torque	Tpk	IN-LBS[Nm]		290.5[32.7]	290.5[32.7]	406.7[45.7]	406.7[45.7]
Peak Current		AMPS		46.8	23.4	65.6	32.8
Max. Theoretical Accel.		RAD/SEC <sup>2</sup>		44,015	44,015	42,811	42,811
Torque Sensitivity	Kt	IN-LBS/AMP[Nm/AMP]		6.2[0.71]	12.4[1.40]	6.2[0.71]	12.4[1.40]
Back EMF (Line to Line)	±10%	Vrms/Krpm		55.0	110.0	55.0	110.0
D.C. Resistance (P-P)	±10%	OHMS		.40	1.8	.27	1.1
Inductance (P-P)	±10%	MILLIHENRIES		2.8	12.6	2.0	8.1
Rotor Inertia	Jm	IN-LBS-SEC <sup>2</sup> [Kg-M <sup>2</sup> ]		.0066[.00074]	.0066[.00074]	.0095[.00107]	.0095[.00107]
Static Friction	Tf	IN-LBS[Nm]		1.4[0.16]	1.4[0.16]	1.8[0.2]	1.8[0.2]
Motor Weight		LBS[Kg]		27.6[12.5]	27.6[12.5]	37.0[16.8]	37.0[16.8]
Line Voltage		VAC		230	230	230	230

**Brake Info:**

Min. Holding Torque: 240IN-LBS  
 Input Voltage: 24VDC  
 Current : .88AMPS  
 Inertia : .000412IN-LB-SEC<sup>2</sup>  
 Weight Adder: 6 LBS

\*25° C Ambient with a maximum case temperature of 100° C on motor. Motor mounted on a 12" x 12" x 1/2" aluminum heatsink. Thermostat in stator windings will open if winding temperature exceeds 155° C. This allows +10% headroom in the continuous torque rating before thermostat opens.

**Mechanical Notes:**

1. Axial Load: 50 LBS. Max.
2. Radial Load: 100 LBS. Max. @ 1" from face
3. Motor Sealed to IP65

**Custom Designed Servo Motors For Your Specific Application. Call 1-800-358-9070 Today.**

**Motor Data (Sine)**

Motor Parameters		Units	1141CSJ****	1141DSJ****
Horsepower	Hp Rated	Hp	2.1	1.2
Kilowatts	KW Rated	KW	1.6	.88
Max. Operating Speed	N Max	RPM	4200	2100
Speed @ Rated Torque	N Rated	RPM	3000	1500
*Continuous Rated Torque @ Rated Speed		IN-LBS[Nm]	45.0[5.1]	50.0[5.6]
*Continuous Stall Torque		IN-LBS[Nm]	54.0[6.1]	54.0[6.1]
Continuous Line Current		AMPS/(RMS/φ)	3.1	1.6
Peak Torque	Tpk	IN-LBS[Nm]	189.0[21.3]	189.0[21.3]
Peak Current		AMPS/(RMS/φ)	10.8	5.4
Max. Theoretical Accel.		RAD/SEC <sup>2</sup>	54,000	54,000
Torque Sensitivity	Kt	IN-LBS/AMP/(RMS/φ)[Nm/AMP/(RMS/φ)]	17.5[1.98]	34.9[3.94]
Back EMF (Line to Line)	±10%	Vrms/Krpm	110.0	220.0
D.C.Resistance (P-P)	±10%	OHMS	3.2	13.3
Inductance (P-P)	±10%	MILLIHENRIES	24.0	99.0
Rotor Inertia	Jm	IN-LBS-SEC <sup>2</sup> [Kg-M <sup>2</sup> ]	.0035[.00039]	.0035[.00039]
Static Friction	Tf	IN-LBS[Nm]	1.0[0.11]	1.0[0.11]
Motor Weight		LBS[Kg]	19.4[8.8]	19.4[8.8]
Line Voltage		VAC	460	460

Motor Parameters		Units	1142CSJ****	1142DSJ****	1143CSJ****	1143DSJ****
Horsepower	Hp Rated	Hp	3.3	1.8	4.6	2.4
Kilowatts	KW Rated	KW	2.5	1.3	3.4	1.8
Max. Operating Speed	N Max	RPM	4200	2100	4200	2100
Speed @ Rated Torque	N Rated	RPM	3000	1500	3000	1500
*Continuous Rated Torque @ Rated Speed		IN-LBS[Nm]	69.1[7.8]	75.0[8.4]	96.8[10.9]	104.0[11.7]
*Continuous Stall Torque		IN-LBS[Nm]	83.0[9.3]	83.0[9.3]	116.2[13.1]	116.2[13.1]
Continuous Line Current		AMPS/(RMS/φ)	4.7	2.3	6.6	3.3
Peak Torque	Tpk	IN-LBS[Nm]	290.5[32.7]	290.5[32.7]	406.7[45.7]	406.7[45.7]
Peak Current		AMPS/(RMS/φ)	16.5	8.3	23.2	11.6
Max. Theoretical Accel.		RAD/SEC <sup>2</sup>	44,015	44,015	42,811	42,811
Torque Sensitivity	Kt	IN-LBS/AMP/(RMS/φ)[Nm/AMP/(RMS/φ)]	17.5[1.98]	34.9[3.94]	17.5[1.98]	34.9[3.94]
Back EMF (Line to Line)	±10%	Vrms/Krpm	1100	2200	1100	2200
D.C.Resistance (P-P)	±10%	OHMS	1.8	6.3	1.0	3.9
Inductance (P-P)	±10%	MILLIHENRIES	12.1	47.4	7.8	29.6
Rotor Inertia	Jm	IN-LBS-SEC <sup>2</sup> [Kg-M <sup>2</sup> ]	.0066[.00074]	.0066[.00074]	.0095[.00107]	.0095[.00107]
Static Friction	Tf	IN-LBS[Nm]	1.4[0.16]	1.4[0.16]	1.8[0.2]	1.8[0.2]
Motor Weight		LBS[Kg]	27.6[12.5]	27.6[12.5]	37.0[16.8]	37.0[16.8]
Line Voltage		VAC	460	460	460	460

**Brake Info:**

Min. Holding Torque: 240IN-LBS  
 Input Voltage: 24VDC  
 Current : .88 AMPS  
 Inertia : .000412IN-LB-SEC<sup>2</sup>  
 Weight Adder: 6 LBS

\*25° C Ambient with a maximum case temperature of 100° C on motor. Motor mounted on a 12" x 12" x 1/2" aluminum heatsink. Thermostat in stator windings will open if winding temperature exceeds 155° C. This allows +10% headroom in the continuous torque rating before thermostat opens.

Mechanical Notes:

1. Axial Load: 50 LBS, Max.
2. Radial Load: 100 LBS, Max. @ 1" from face
3. Motor Sealed to IP65

**Motor Data (Trap)**

Motor Parameters		Units	1141CTJ****	1141DTJ****
Horsepower	Hp Rated	Hp	2.1	1.2
Kilowatts	KW Rated	KW	1.6	.88
Max. Operating Speed	N Max	RPM	4200	2100
Speed @ Rated Torque	N Rated	RPM	3000	1500
*Continuous Rated Torque @ Rated Speed		IN-LBS[Nm]	45.0[5.1]	50.0[5.6]
*Continuous Stall Torque		IN-LBS[Nm]	54.0[6.1]	54.0[6.1]
Continuous Line Current		AMPS	4.4	2.2
Peak Torque	Tpk	IN-LBS[Nm]	189.0[21.3]	189.0[21.3]
Peak Current		AMPS	15.3	7.6
Max. Theoretical Accel.		RAD/SEC <sup>2</sup>	54,000	54,000
Torque Sensitivity	Kt	IN-LBS/AMP[Nm/AMP]	12.4[1.40]	24.7[2.79]
Back EMF (Line to Line)	±10%	Vrms/Krpm	1100	220.0
D.C.Resistance (P-P)	±10%	OHMS	3.2	13.3
Inductance (P-P)	±10%	MILLIHENRIES	24.0	99.0
Rotor Inertia	Jm	IN-LBS-SEC <sup>2</sup> [Kg-M <sup>2</sup> ]	.0035[.00039]	.0035[.00039]
Static Friction	Tf	IN-LBS[Nm]	1.0[0.11]	1.0[0.11]
Motor Weight		LBS[Kg]	19.4[8.8]	19.4[8.8]
Line Voltage		VAC	460	460

Motor Parameters		Units	1142CTJ****	1142DTJ****	1143CTJ****	1143DTJ****
Horsepower	Hp Rated	Hp	3.3	1.8	4.6	2.4
Kilowatts	KW Rated	KW	2.5	1.3	3.4	1.8
Max. Operating Speed	N Max	RPM	4200	2100	4200	2100
Speed @ Rated Torque	N Rated	RPM	3000	1500	3000	1500
*Continuous Rated Torque @ Rated Speed		IN-LBS[Nm]	69.1[7.8]	75.0[8.4]	96.8[10.9]	104.0[11.7]
*Continuous Stall Torque		IN-LBS[Nm]	83.0[9.3]	83.0[9.3]	116.2[13.1]	116.2[13.1]
Continuous Line Current		AMPS	6.7	3.3	9.4	4.7
Peak Torque	Tpk	IN-LBS[Nm]	290.5[32.7]	290.5[32.7]	406.7[45.7]	406.7[45.7]
Peak Current		AMPS	23.4	11.7	32.8	16.4
Max. Theoretical Accel.		RAD/SEC <sup>2</sup>	44,015	44,015	42,811	42,811
Torque Sensitivity	Kt	IN-LBS/AMP[Nm/AMP]	12.4[1.40]	24.7[2.79]	12.4[1.40]	24.7[2.79]
Back EMF (Line to Line)	±10%	Vrms/Krpm	1100	2200	1100	2200
D.C.Resistance (P-P)	±10%	OHMS	1.8	6.3	1.0	3.9
Inductance (P-P)	±10%	MILLIHENRIES	12.1	47.4	7.8	29.6
Rotor Inertia	Jm	IN-LBS-SEC <sup>2</sup> [Kg-M <sup>2</sup> ]	.0066[.00074]	.0066[.00074]	.0095[.00107]	.0095[.00107]
Static Friction	Tf	IN-LBS[Nm]	1.40[.16]	1.4[0.16]	1.8[0.2]	1.8[0.2]
Motor Weight		LBS[Kg]	27.6[12.5]	27.6[12.5]	37.0[16.8]	37.0[16.8]
Line Voltage		VAC	460	460	460	460

**Brake Info:**

Min. Holding Torque: 240IN-LBS  
 Input Voltage: 24VDC  
 Current : .88AMPS  
 Inertia : .000412IN-LB-SEC<sup>2</sup>  
 Weight Adder: 6 LBS

\*25° C Ambient with a maximum case temperature of 100° C on motor. Motor mounted on a 12" x 12" x 1/2" aluminum heatsink. Thermostat in stator windings will open if winding temperature exceeds 155° C. This allows +10% headroom in the continuous torque rating before thermostat opens.

Mechanical Notes:

1. Axial Load: 50 LBS. Max.
2. Radial Load: 100 LBS. Max. @ 1" from face
3. Motor Sealed to IP65

Custom Designed Servo Motors For Your Specific Application. Call 1-800-358-9070 Today.

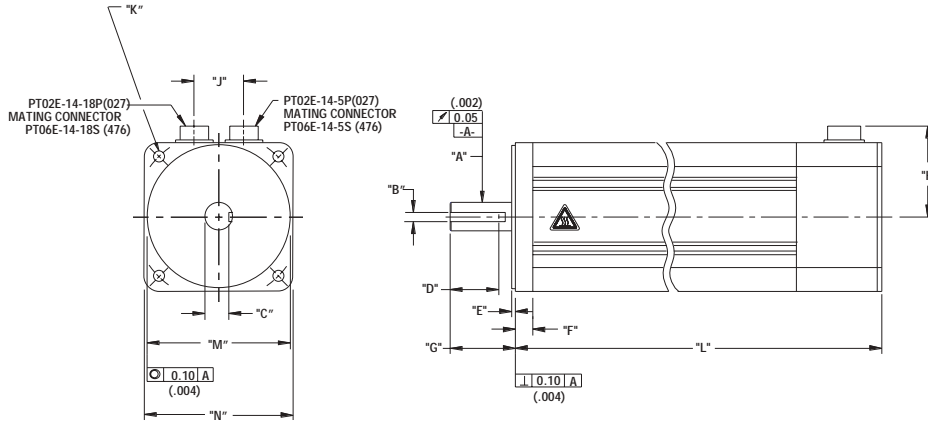

**4" (114) English and Metric Connectorized Termination-Option 1 Motors**

Model	"A"	"B"	"C"	"D"	"E"	"F"	"G"
<b>MPM1141***6***</b>	ø .6245(15.862) .6241(15.852)	.1890(4.801) .1875(4.763)	.509(12.93)	1.5(38.1)Min	.10(2.5)	.53(13.5)	1.90(48.2) 1.86(47.1)
<b>MPM1141***7***</b>	ø 18.999(.7480) 18.987(.7475)	5.99(.236) 5.97(.235)	15.49(.610)	37.0(1.46)Min	3.0(.12)	13.0(.51)	50.5(1.99) 49.5(1.95)
<b>MPM1142***6***</b>	ø .8750(22.225) .8745(22.212)	.1890(4.801) .1875(4.763)	.774(19.65)	1.5(38.1)Min	.10(2.5)	.53(13.5)	1.90(48.2) 1.86(47.1)
<b>MPM1142***7***</b>	ø 24.000(.9449) 23.988(.9444)	7.998(.3149) 7.963(.3135)	19.90(.784)	37.0(1.46)Min	3.0(.12)	13.0(.51)	50.5(1.99) 49.5(1.95)
<b>MPM1143***6***</b>	ø .8750(22.225) .8745(22.212)	.1890(4.801) .1875(4.763)	.774(19.65)	1.5(38.1)Min	.10(2.5)	.53(13.5)	1.90(48.2) 1.86(47.1)
<b>MPM1143***7***</b>	ø 24.000(.9449) 23.988(.9444)	7.998(.3149) 7.963(.3135)	19.90(.784)	37.0(1.46)Min	3.0(.12)	13.0(.51)	50.5(1.99) 49.5(1.95)

Model	"H"	"J"	"K"	"L"	"L" w/ Brake	"M"	"N"
<b>MPM1141***6***</b>	2.8(71)Max	1.5(38.0)	3/8-16UNC-2B THRU (4)EQ SPD AS SHOWN ON Ø5.875(149.23)B.C.	8.61(218.7)Max	10.61(269.5)	ø 4.500(114.30) 4.499(114.27)	□ 5.00(127.0)
<b>MPM1141***7***</b>	71(2.8)Max	38.0(1.5)	Ø9.18(.362)THRU (4)EQ SPD AS SHOWN ON Ø130.00(5.118)B.C.	218.2(8.59)Max	269.0(10.59)	ø 110.01(4.331) 109.98(4.330)	□ 114.3(4.50)
<b>MPM1142***6***</b>	2.8(71)Max	1.5(38.0)	3/8-16UNC-2B THRU (4)EQ SPD AS SHOWN ON Ø5.875(149.23)B.C.	11.11(282.2)Max	13.11(333.0)	ø 4.500(114.30) 4.499(114.27)	□ 5.00(127.0)
<b>MPM1142***7***</b>	71(2.8)Max	38.0(1.5)	Ø9.18(.362)THRU (4)EQ SPD AS SHOWN ON Ø130.00(5.118)B.C.	281.7(11.09)Max	332.5(13.09)	ø 110.01(4.331) 109.98(4.330)	□ 114.3(4.50)
<b>MPM1143***6***</b>	2.8(71)Max	1.5(38.0)	3/8-16UNC-2B THRU (4)EQ SPD AS SHOWN ON Ø5.875(149.23)B.C.	13.61(345.7)Max	15.61(396.5)	ø 4.500(114.30) 4.499(114.27)	□ 5.00(127.0)
<b>MPM1143***7***</b>	71(2.8)Max	38.0(1.5)	Ø9.18(.362)THRU (4)EQ SPD AS SHOWN ON Ø130.00(5.118)B.C.	345.2(13.59)Max	396.0(15.59)	ø 110.01(4.331) 109.98(4.330)	□ 114.3(4.50)

English = 6 Units: in (mm)  
 Metric = 7 Units: mm (in)

For Mechanical Dimensions on Termination Option 2 Consult Factory.

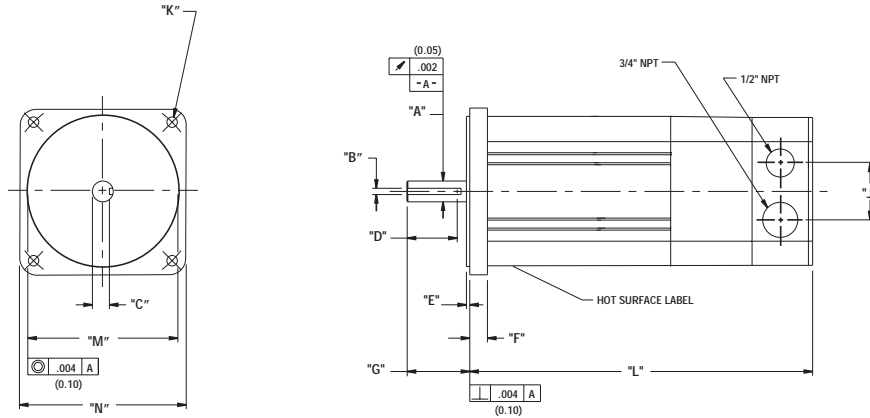

**4" (114) English and Metric NPT Termination-Option 3 Motors**

Model	"A"	"B"	"C"	"D"	"E"	"F"	"G"
MPM1141***6***	∅ .6245(15.862) ∅ .6241(15.852)	.1890(4.801) .1875(4.763)	.509(12.93)	1.5(38.1)Min	.10(2.5)	.53(13.5)	1.90(48.2) 1.86(47.1)
MPM1141***7***	∅ 18.999(.7480) ∅ 18.987(.7475)	5.99(.236) 5.97(.235)	15.49(610)	37.0(1.46)Min	3.0(.12)	13.0(.51)	50.5(1.99) 49.5(1.95)
MPM1142***6***	∅ .8750(22.225) ∅ .8745(22.212)	.1890(4.801) .1875(4.763)	.774(19.65)	1.5(38.1)Min	.10(2.5)	.53(13.5)	1.90(48.2) 1.86(47.1)
MPM1142***7***	∅ 24.000(.9449) ∅ 23.988(.9444)	7.998(.3149) 7.963(.3135)	19.90(.784)	37.0(1.46)Min	3.0(.12)	13.0(.51)	50.5(1.99) 49.5(1.95)
MPM1143***6***	∅ .8750(22.225) ∅ .8745(22.212)	.1890(4.801) .1875(4.763)	.774(19.65)	1.5(38.1)Min	.10(2.5)	.53(13.5)	1.90(48.2) 1.86(47.1)
MPM1143***7***	∅ 24.000(.9449) ∅ 23.988(.9444)	7.998(.3149) 7.963(.3135)	19.90(.784)	37.0(1.46)Min	3.0(.12)	13.0(.51)	50.5(1.99) 49.5(1.95)

Model	"J"	"K"	"L"	"L" w/ Brake	"M"	"N"
MPM1141***6***	1.71(43.4)	3/8-16UNC-2B THRU (4)EQ SPD AS SHOWN ON ∅5.875(149.23) B.C.	10.30(261.6)Max	12.30(312.42)	∅ 4.500(114.30) 4.499(114.27)	□ 5.00(127.0)
MPM1141***7***	43.4(1.71)	∅9.18(.362)THRU (4)EQ SPD AS SHOWN ON ∅130.00(5.118) B.C.	261.0(10.28)Max	311.9(12.28)	∅ 110.00(4.331) 109.98(4.330)	□ 114.3(4.50)
MPM1142***6***	1.71(43.4)	3/8-16UNC-2B THRU (4)EQ SPD AS SHOWN ON ∅5.875(149.23) B.C.	12.80(325.1)Max	14.80(375.92)	∅ 4.500(114.30) 4.499(114.27)	□ 5.00(127.0)
MPM1142***7***	43.4(1.71)	∅9.18(.362)THRU (4)EQ SPD AS SHOWN ON ∅130.00(5.118) B.C.	324.5(12.78)Max	375.4(14.78)	∅ 110.00(4.331) 109.98(4.330)	□ 114.3(4.50)
MPM1143***6***	1.71(43.4)	3/8-16UNC-2B THRU (4)EQ SPD AS SHOWN ON ∅5.875(149.23) B.C.	15.30(388.6)Max	17.30(439.42)	∅ 4.500(114.30) 4.499(114.27)	□ 5.00(127.0)
MPM1143***7***	43.4(1.71)	∅9.18(.362)THRU (4)EQ SPD AS SHOWN ON ∅130.00(5.118) B.C.	388.0(15.28)Max	438.9(17.28)	∅ 110.00(4.331) 109.98(4.330)	□ 114.3(4.50)

English = 6 Units: in (mm)  
 Metric = 7 Units: mm (in)

For Mechanical Dimensions on Termination Option 2 Consult Factory.

**Custom Designed Servo Motors For Your Specific Application. Call 1-800-358-9070 Today.**

**4" Motor with Resolver Feedback**

**Option 1**

Motor Connector 270-00026 (PT02E-14-5P(027))	
Pin	Function
A	$\phi$ R
B	$\phi$ S
C	$\phi$ T
D	PE GND
E	-

Resolver Connector 270-00024 (PT02E-14-18P(027))	
Pin	Function
U	THERM
N	THERM
H	SIN
G	COS GND
S	COS
F	SIN GND
R	REF GND
E	REF
D	RES SHLD
P	GND
A	-
B	-
C	-
J	-
K	-
L	-
M	-
T	-

**\* Option 1 with brake**

Motor Brake Connector 270-00032 (PT02E-16-8P(027))	
Pin	Function
A	$\phi$ R
B	$\phi$ S
C	$\phi$ T
D	PE GND
E	BRK SHLD
F	BRK (+)
G	BRK (-)
H	-

**Option 2**

Motor Brake Connector 270-00256 (BEGA0589NN000009000)	
Pin	Function
1	$\phi$ R (U1)
2	PE GND
3	$\phi$ T (W1)
4	$\phi$ S (V1)
*A	BRK (+)
*B	BRK (-)
C	THERM
D	THERM

**\* USE ONLY WITH BRAKE OPTION**

Resolver Connector 270-00257 (AEGA052NN0000013000)	
Pin	Function
1	-
2	REF (R1)
3	REF GND (R2)
4	COS GND (S1)
5	COS (S3)
6	SIN (S2)
7	SIN GND (S4)
8	-
9	-
10	-
11	-
12	-

**Option 3**

Connection Chart (NPT) Resolver	
Terminal	Function
R	$\phi$ R
S	$\phi$ S
T	$\phi$ T
GND	PE GND
*S11	BRK (+)
*S10	BRK (-)
S9	REF GND
S8	REF
S7	SIN
S6	COS
S5	COS GND
S4	SIN GND
S3	THERM
S2	THERM
S1	RES SHLD

**\* USE ONLY WITH BRAKE OPTION**

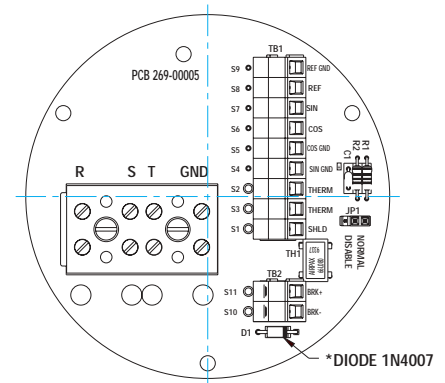

**4" Motor with Encoder Feedback**

**Option 1**

**Motor Connector 270-00026 (PT02E-14-5P(027))**



Pin	Function
A	$\phi$ R
B	$\phi$ S
C	$\phi$ T
D	PE GND
E	-

**Encoder Connector 270-00024 (PT02E-14-18P(027))**

Pin	Function
T	GND
K	+5VDC
B	CH A
C	CH A\
N	CH B
P	CH B\
M	CH Z
U	CH Z\
E	CH U
R	CH U\
F	CH V
S	CH V\
G	CH W
H	CH W\
D	GND/CABLE
A	THERM
L	THERM
J	GND

**Option 1 with brake**



**Motor Brake Connector 270-00032 (PT02E-16-8P(027))**

Pin	Function
A	$\phi$ R
B	$\phi$ S
C	$\phi$ T
D	PE GND
E	BRK SHLD
F	BRK (+) 
G	BRK (-) 
H	-

**Option 3-Consult Factory**

**Option 2**

**Motor Brake Connector 270-00256 (BEGA089NN00000013000)**

Pin	Function
1	$\phi$ R (U1)
2	PE GND
3	$\phi$ T (W1)
4	$\phi$ S (V1)
*A	BRK (+) 
*B	BRK (-) 
C	THERM
D	THERM

\*USE ONLY WITH BRAKE OPTION

**Encoder Connector 270-00257 (AEGA052NN00000013000)**

Pin	Function
1	GND (0V)
2	CH A\ (A)
3	CH A (A\)
4	CH B (B)
5	CH B\ (B\)
6	CH Z (Z)
7	CH Z\ (Z\)
8	+5V (+5V)
9	-
10	CH U (RLGU)
11	CH V (RLGV)
12	CH W (RLGW)

Custom Designed Servo Motors For Your Specific Application. Call 1-800-358-9070 Today.

# 6" Frame Brushless Servo Motors



## Motor Data (Sine)

Motor Parameters		Units	421ASG****	1421BSG***	1422ASG****
Horsepower	Hp Rated	Hp	4.4	2.6	6.8
Kilowatts	KW Rated	KW	3.2	2.1	5.1
Max. Operating Speed	N Max	RPM	2700	1750	2700
Speed @ Rated Torque	N Rated	RPM	2400	1500	2400
*Continuous Rated Torque @ Rated Speed		IN-LBS[Nm]	115.0[13.0]	120.0[13.5]	179.0[20.2]
*Continuous Stall Torque		IN-LBS[Nm]	130.0[14.7]	130.0[14.7]	210.0[23.7]
Continuous Line Current		AMPS(RMS $\phi$ )	11.6	6.9	18.7
Peak Torque	Tpk	IN-LBS[Nm]	390.0[43.9]	390.0[43.9]	630.0[70.8]
Peak Current		AMPS(RMS $\phi$ )	33.9	20.9	56.3
Max. Theoretical Accel.		RAD/SEC <sup>2</sup>	36,792	36,792	33,511
Torque Sensitivity	Kt	IN-LBS/AMP (RMS $\phi$ )[Nm/AMP(RMS $\phi$ )]	11.2[1.26]	18.8[2.06]	11.2[1.26]
Back EMF (Line to Line)	±10%	Vrms/Krpm	70.0	115.0	70.0
D.C.Resistance (P-P)	±10%	OHMS	.66	1.7	.24
Inductance (P-P)	±10%	MILLIHENRIES	4.7	122	2.0
Rotor Inertia	Jm	IN-LBS-SEC <sup>2</sup> [Kg-M <sup>2</sup> ]	.0106 [.00119]	.0106 [.00119]	.0188 [.00212]
Static Friction	Tf	IN-LBS[Nm]	2.4[0.27]	2.4[0.27]	3.0[0.34]
Motor Weight		LBS[Kg]	36.0[16.3]	36.0[16.3]	51.0[23.1]
Line Voltage		VAC	230	230	230

Motor Parameters		Units	1422BSG****	1423ASG****	1423BSG****	1424ASG****	1424BSG****
Horsepower	Hp Rated	Hp	4.5	9.1	6.0	102	7.6
Kilowatts	KW Rated	KW	3.4	6.8	4.5	7.6	5.7
Max. Operating Speed	N Max	RPM	1750	2700	1750	2400	1750
Speed @ Rated Torque	N Rated	RPM	1500	2400	1500	2100	1500
*Continuous Rated Torque @ Rated Speed		IN-LBS[Nm]	190.0[21.3]	238.0[26.9]	252.0[28.2]	306.0[34.6]	320.0[36.0]
*Continuous Stall Torque		IN-LBS[Nm]	210.0[23.7]	280.0[31.5]	280.0[31.5]	360.0[40.7]	360.0[40.7]
Continuous Line Current		AMPS(RMS/ $\phi$ )	11.2	25.0	14.9	24.0	19.2
Peak Torque	Tpk	IN-LBS[Nm]	630.0[70.8]	840.0[94.4]	840.0[94.4]	1081.0[122.2]	1081.0[122.2]
Peak Current		AMPS(RMS/ $\phi$ )	33.5	75.2	44.7	72.1	57.5
Max. Theoretical Accel.		RAD/SEC <sup>2</sup>	33,511	30,769	30,769	30,710	30,710
Torque Sensitivity	Kt	IN-LBS/AMP (RMS $\phi$ )[Nm/AMP(RMS $\phi$ )]	18.2[2.06]	11.2[1.26]	18.2[2.06]	15.0[1.70]	18.2[2.06]
Back EMF (Line to Line)	±10%	Vrms/Krpm	115.0	70.0	115.0	93.0	115.0
D.C.Resistance (P-P)	±10%	OHMS	.72	.13	.45	.18	.26
Inductance (P-P)	±10%	MILLIHENRIES	6.1	1.4	4.3	1.7	2.9
Rotor Inertia	Jm	IN-LBS-SEC <sup>2</sup> [Kg-M <sup>2</sup> ]	.0188[.00212]	.0273[.00308]	.0273[.00308]	.0352[.00397]	.0352[.00397]
Static Friction	Tf	IN-LBS[Nm]	3.0[0.34]	3.6[0.41]	3.6[0.41]	4.2[0.47]	4.2[0.47]
Motor Weight		LBS[Kg]	51.0[23.1]	66.0[29.9]	66.0[29.9]	83.0[37.7]	83.0[37.7]
Line Voltage		VAC	230	230	230	230	230

### Brake Info:

Min. Holding Torque: 360IN-LBS  
 Input Voltage: 24VDC  
 Current: 1.13AMPS  
 Inertia: .00227IN-LB-SEC<sup>2</sup>  
 Weight Added: 12LBS

\*25° C Ambient with a maximum case temperature of 100° C on motor. Motor mounted on a 12" x 12" x 1/2" aluminum heatsink. Thermostat in stator windings will open if winding temperature exceeds 155° C. This allows for an approximate +10% headroom in the continuous torque rating before thermostat opens.

#### Mechanical Notes:

1. Axial Load: 50 LBS. Max.
2. Radial Load: 150 LBS. Max. @ 1" from face
3. Motor Sealed to IP65

**Motor Data (Trap)**

Motor Parameters		Units	1421ATG****	1421BTG****	1422ATG****	1422BTG****
<b>Horsepower</b>	Hp Rated	Hp	4.4	2.9	6.8	4.5
<b>Kilowatts</b>	KW Rated	KW	3.2	2.1	5.1	3.4
<b>Max. Operating Speed</b>	N Max	RPM	2700	1750	2700	1750
<b>Speed @ Rated Torque</b>	N Rated	RPM	2400	1500	2400	1500
<b>*Continuous Rated Torque @ Rated Speed</b>		IN-LBS[Nm]	115.0 [13.0]	120.0 [13.5]	179.0 [20.2]	190.0 [21.3]
<b>*Continuous Stall Torque</b>		IN-LBS[Nm]	130.0 [14.7]	130.0 [14.7]	210.0 [23.7]	210.0 [23.7]
<b>Continuous Line Current</b>		AMPS	16.9	9.8	26.5	15.8
<b>Peak Torque</b>	Tpk	IN-LBS[Nm]	390.0 [43.9]	390.0 [43.9]	630.0 [70.8]	630.0 [70.8]
<b>Peak Current</b>		AMPS	48.0	29.6	79.6	47.4
<b>Max. Theoretical Accel.</b>		RAD/SEC <sup>2</sup>	36,792	36,792	33,511	33,511
<b>Torque Sensitivity</b>	Kt	IN-LBS/AMP[Nm/AMP]	7.9 [0.89]	12.9 [1.46]	7.9 [0.89]	12.9 [1.46]
<b>Back EMF (Line to Line)</b>	±10%	Vrms/Krpm	70.0	115.0	70.0	115.0
<b>D. C. Resistance (P-P)</b>	±10%	OHMS	.66	1.7	.24	.72
<b>Inductance (P-P)</b>	±10%	MILLIHENRIES	4.7	12.6	2.0	6.1
<b>Rotor Inertia</b>	Jm	IN-LBS-SEC <sup>2</sup> [Kg-M <sup>2</sup> ]	.0106 [.00119]	.0106 [.00119]	.0188 [.00212]	.0188 [.00212]
<b>Static Friction</b>	Tf	IN-LBS[Nm]	2.4 [0.27]	2.4 [0.27]	3.0 [0.34]	3.0 [0.34]
<b>Motor Weight</b>		LBS[Kg]	36.0 [16.3]	36.0 [16.3]	51.0 [23.1]	51.0 [23.1]
<b>Line Voltage</b>		VAC	230	230	230	230

Motor Parameters		Units	1423ATG****	1423BTG****	1424ATG****	1424BTG****
<b>Horsepower</b>	Hp Rated	Hp	9.1	6.0	10.2	7.6
<b>Kilowatts</b>	KW Rated	KW	6.8	4.5	7.6	5.7
<b>Max. Operating Speed</b>	N Max	RPM	2700	1750	2400	1750
<b>Speed @ Rated Torque</b>	N Rated	RPM	2400	1500	2100	1500
<b>*Continuous Rated Torque @ Rated Speed</b>		IN-LBS[Nm]	238.0 [26.9]	252.0 [28.2]	306.0 [34.6]	320.0 [36.0]
<b>*Continuous Stall Torque</b>		IN-LBS[Nm]	280.0 [31.5]	280.0 [31.5]	360.0 [40.7]	360.0 [40.7]
<b>Continuous Line Current</b>		AMPS	35.4	21.1	34.0	27.1
<b>Peak Torque</b>	Tpk	IN-LBS[Nm]	840.0 [94.4]	840.0 [94.4]	1081.0 [122.2]	1081.0 [122.2]
<b>Peak Current</b>		AMPS	106.3	63.2	102.0	81.3
<b>Max. Theoretical Accel.</b>		RAD/SEC <sup>2</sup>	30,769	30,769	30,710	30,710
<b>Torque Sensitivity</b>	Kt	IN-LBS/AMP[Nm/AMP]	7.9 [0.89]	12.9 [1.46]	10.4 [1.2]	12.9 [1.46]
<b>Back EMF (Line to Line)</b>	±10%	Vrms/Krpm	70.0	115.0	93.0	115.0
<b>D. C. Resistance (P-P)</b>	±10%	OHMS	.13	.45	.18	.26
<b>Inductance (P-P)</b>	±10%	MILLIHENRIES	1.4	4.3	1.7	2.9
<b>Rotor Inertia</b>	Jm	IN-LBS-SEC <sup>2</sup> [Kg-M <sup>2</sup> ]	.0273 [.00308]	.0273 [.00308]	.0352 [.00397]	.0352 [.00397]
<b>Static Friction</b>	Tf	IN-LBS[Nm]	3.6 [0.41]	3.6 [0.41]	4.2 [0.47]	4.2 [0.47]
<b>Motor Weight</b>		LBS[Kg]	66.0 [29.9]	66.0 [29.9]	83.0 [37.7]	83.0 [37.7]
<b>Line Voltage</b>		VAC	230	230	230	230

**Brake Info:**

**Min. Holding Torque:** 360IN-LBS  
**Input Voltage:** 24VDC  
**Current :** 1.13AMPS  
**Inertia:** .00227IN-LB-SEC<sup>2</sup>  
**Weight Added:** 12LBS

\*25° C Ambient with a maximum case temperature of 100° C on motor. Motor mounted on a 12" x 12" x 1/2" aluminum heatsink. Thermostat in stator windings will open if winding temperature exceeds 155° C. This allows for an approximate +10% headroom in the continuous torque rating before thermostat opens.

**Mechanical Notes:**

1. Axial Load: 50 LBS. Max.
2. Radial Load: 150 LBS. Max. @ 1" from face
3. Motor Sealed to IP65

**Custom Designed Servo Motors For Your Specific Application. Call 1-800-358-9070 Today.**

**Motor Data (Sine)**

Motor Parameters		Units	1421CSJ****	1421DSJ****	1422CSJ****
Horsepower	Hp Rated	Hp	4.9	2.9	7.5
Kilowatts	KW Rated	KW	3.6	2.1	5.7
Max. Operating Speed	N Max	RPM	3400	1750	3400
Speed @ Rated Torque	N Rated	RPM	2800	1500	2800
*Continuous Rated Torque @ Rated Speed		IN-LBS[Nm]	110.0[12.4]	120.0[13.5]	170.0[19.2]
*Continuous Stall Torque		IN-LBS[Nm]	130.0[14.7]	130.0[14.7]	210.0[23.7]
Continuous Line Current		AMPS/(RMS/φ)	6.9	3.5	112
Peak Torque	Tpk	IN-LBS[Nm]	390.0[43.9]	390.0[43.9]	630.0[70.8]
Peak Current		AMPS/(RMS/φ)	20.9	10.5	335
Max. Theoretical Accel.		RAD/SEC <sup>2</sup>	36,792	36,792	33,511
Torque Sensitivity	Kt	IN-LBS/AMP (RMS/φ)[Nm/AMP (RMS/φ)]	18.2[2.1]	36.5[4.1]	18.2[2.1]
Back EMF (Line to Line)	±10%	Vrms/Krpm	115.0	230.0	115.0
D.C. Resistance (P-P)	±10%	OHMS	1.9	7.1	.68
Inductance (P-P)	±10%	MILLIHENRIES	13.0	52.3	5.6
Rotor Inertia	Jm	IN-LBS-SEC <sup>2</sup> [Kg-M <sup>2</sup> ]	.0106[.00119]	.0106[.00119]	.0188[.00212]
Static Friction	Tf	IN-LBS[Nm]	2.4[0.27]	2.4[0.27]	3.0[0.34]
Motor Weight		LBS[Kg]	36.0[16.3]	36.0[16.3]	51.0[23.1]
Line Voltage		VAC	460	460	460

Motor Parameters		Units	1422DSJ****	1423CSJ****	1423DSJ****	1424CSJ****	1424DSJ****
Horsepower	Hp Rated	Hp	4.5	9.8	6.0	124	7.6
Kilowatts	KW Rated	KW	3.4	7.3	4.5	9.3	5.7
Max. Operating Speed	N Max	RPM	1750	3400	1750	3400	1750
Speed @ Rated Torque	N Rated	RPM	1500	2800	1500	2800	1500
*Continuous Rated Torque @ Rated Speed		IN-LBS[Nm]	190.0[21.3]	220.0[24.8]	252.0[28.2]	280.0[31.6]	320.0[36.0]
*Continuous Stall Torque		IN-LBS[Nm]	210.0[23.7]	280.0[31.5]	280.0[31.5]	360.0[40.7]	360.0[40.7]
Continuous Line Current		AMPS/(RMS/φ)	5.6	14.9	7.5	192	9.6
Peak Torque	Tpk	IN-LBS[Nm]	630.0[70.8]	840.0[94.4]	840.0[94.4]	1081.0[122.2]	1081.0[122.2]
Peak Current		AMPS/(RMS/φ)	16.8	44.7	22.3	57.5	287
Max. Theoretical Accel.		RAD/SEC <sup>2</sup>	33,511	30,769	30,769	30,710	30,710
Torque Sensitivity	Kt	IN-LBS/AMP (RMS/φ)[Nm/AMP (RMS/φ)]	36.5[4.1]	18.2[2.1]	36.5[4.1]	18.2[2.1]	36.5[4.1]
Back EMF (Line to Line)	±10%	Vrms/Krpm	230.0	115.0	230.0	115.0	2300
D.C. Resistance (P-P)	±10%	OHMS	2.5	.45	1.7	.26	1.2
Inductance (P-P)	±10%	MILLIHENRIES	230	4.3	16.9	2.9	11.1
Rotor Inertia	Jm	IN-LBS-SEC <sup>2</sup> [Kg-M <sup>2</sup> ]	.0188[.00212]	.0273[.00308]	.0273[.00308]	.0352[.00397]	.0352[.00397]
Static Friction	Tf	IN-LBS[Nm]	3.0[0.34]	3.6[0.41]	3.6[0.41]	4.2[0.47]	4.2[0.47]
Motor Weight		BS[Kg]	51.0[23.1]	66.0[29.9]	66.0[29.9]	83.0[37.7]	83.0[37.7]
Line Voltage		VAC	460	460	460	460	460

**Brake Info:**

Min. Holding Torque: 360IN-LBS  
 Input Voltage: 24VDC  
 Current : 1.13AMPS  
 Inertia : .00227IN-LB-SEC<sup>2</sup>  
 Weight Added: 12LBS

\*25° C Ambient with a maximum case temperature of 100° C on motor. Motor mounted on a 12" x 12" x 1/2" aluminum heatsink. Thermostat in stator windings will open if winding temperature exceeds 155° C. This allows for an approximate +10% headroom in the continuous torque rating before thermostat opens.

Mechanical Notes:

1. Axial Load: 50 LBS. Max.
2. Radial Load: 150 LBS. Max. @ 1" from face
3. Motor Sealed to IP65

**Motor Data (Trap)**

Motor Parameters		Units	1421CTJ****	1421DTJ****	1422CTJ****	1422DTJ****
Horsepower	Hp Rated	Hp	4.9	2.9	7.5	4.5
Kilowatts	KW Rated	KW	3.6	2.1	5.7	3.4
Max. Operating Speed	N Max	RPM	3400	1750	3400	1750
Speed @ Rated Torque	N Rated	RPM	2800	1500	2800	1500
*Continuous Rated Torque @ Rated Speed		IN-LBS[Nm]	110.0[12.4]	120.0[13.5]	170.0[19.2]	190.0[21.3]
*Continuous Stall Torque		IN-LBS[Nm]	130.0[14.7]	130.0[14.7]	210.0[23.7]	210.0[23.7]
Continuous Line Current		AMPS	9.8	4.9	15.8	7.9
Peak Torque	Tpk	IN-LBS[Nm]	390.0[43.9]	390.0[43.9]	630.0[70.8]	630.0[70.8]
Peak Current		AMPS	29.6	14.8	47.4	23.7
Max. Theoretical Accel.		RAD/SEC <sup>2</sup>	36,792	36,792	33,511	33,511
Torque Sensitivity	Kt	IN-LBS/AMP[Nm/AMP]	12.9[1.46]	25.8[2.92]	12.9[1.46]	25.8[2.92]
Back EMF (Line to Line)	±10%	Vrms/Krpm	115.0	230.0	115.0	230.0
D.C.Resistance (P-P)	±10%	OHMS	1.9	7.1	.68	2.5
Inductance (P-P)	±10%	MILLIHENRIES	13.0	52.3	5.6	23.0
Rotor Inertia	Jm	IN-LBS-SEC <sup>2</sup> [Kg-M <sup>2</sup> ]	.0106[.00119]	.0106[.00119]	.0188[.00212]	.0188[.00212]
Static Friction	Tf	IN-LBS[Nm]	2.4[0.27]	2.4[0.27]	3.0[0.34]	3.0[0.34]
Motor Weight		LBS[Kg]	36.0[16.3]	36.0[16.3]	51.0[23.1]	51.0[23.1]
Line Voltage		VAC	460	460	460	460

Motor Parameters		Units	1423CTJ****	1423DTJ****	1424CTJ****	1424DTJ****
Horsepower	Hp Rated	Hp	9.8	6.0	12.4	7.6
Kilowatts	KW Rated	KW	7.3	4.5	9.3	5.7
Max. Operating Speed	N Max	RPM	3400	1750	3400	1750
Speed @ Rated Torque	N Rated	RPM	2800	1500	2800	1500
*Continuous Rated Torque @ Rated Speed		IN-LBS[Nm]	220.0[24.8]	252.0[28.2]	280.0[31.6]	320.0[36.0]
*Continuous Stall Torque		IN-LBS[Nm]	280.0[31.5]	280.0[31.5]	360.0[40.7]	360.0[40.7]
Continuous Line Current		AMPS	21.1	10.6	27.1	13.6
Peak Torque	Tpk	IN-LBS[Nm]	840.0[94.4]	840.0[94.4]	1081.0[122.2]	1081.0[122.2]
Peak Current		AMPS	63.2	31.6	81.3	40.6
Max. Theoretical Accel.		RAD/SEC <sup>2</sup>	30,769	30,769	30,710	30,710
Torque Sensitivity	Kt	IN-LBS/AMP[Nm/AMP]	12.9[1.46]	25.8[2.92]	12.9[1.46]	25.8[2.92]
Back EMF (Line to Line)	±10%	Vrms/Krpm	115.0	230.0	115.0	230.0
D.C.Resistance (P-P)	±10%	OHMS	.45	1.7	.26	1.2
Inductance (P-P)	±10%	MILLIHENRIES	4.3	16.9	2.9	11.1
Rotor Inertia	Jm	IN-LBS-SEC <sup>2</sup> [Kg-M <sup>2</sup> ]	.0273[.00308]	.0273[.00308]	.0352[.00397]	.0352[.00397]
Static Friction	Tf	IN-LBS[Nm]	3.6[0.41]	3.6[0.41]	4.2[0.47]	4.2[0.47]
Motor Weight		LBS[Kg]	66.0[29.9]	66.0[29.9]	83.0[37.7]	83.0[37.7]
Line Voltage		VAC	460	460	460	460

**Brake Info:**

Min. Holding Torque: 360IN-LBS  
 Input Voltage: 24VDC  
 Current: 1.13AMPS  
 Inertia: .00227IN-LB-SEC<sup>2</sup>  
 Weight Added: 12LBS

\*25° C Ambient with a maximum case temperature of 100° C on motor. Motor mounted on a 12" x 12" x 1/2" aluminum heatsink. Thermostat in stator windings will open if winding temperature exceeds 155° C. This allows for an approximate +10% headroom in the continuous torque rating before thermostat opens.

- Mechanical Notes:
1. Axial Load: 50 LBS. Max.
  2. Radial Load: 150 LBS. Max. @ 1" from face
  3. Motor Sealed to IP65

Custom Designed Servo Motors For Your Specific Application. Call 1-800-358-9070 Today.

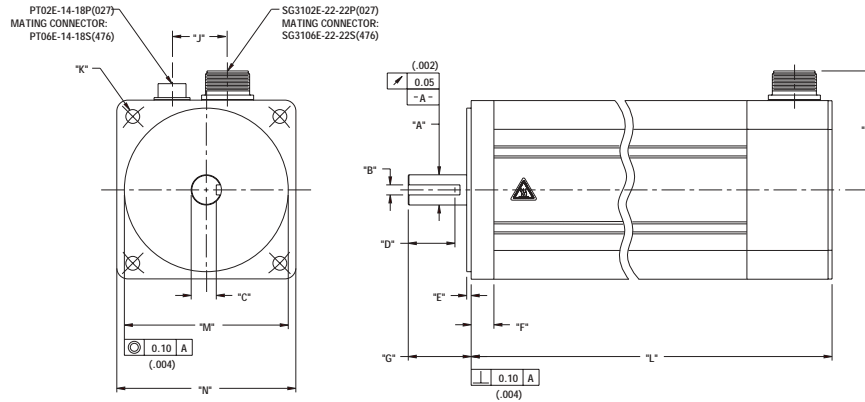

**6" (142) English and Metric Connectorized Termination-Option 1 Motors**

Model	"A"	"B"	"C"	"D"	"E"	"F"	"G"
MPM1421***6***	∅ .8750(22.225) .8745(22.212)	.1890(4.801) .1875(4.763)	.774(19.66)	1.41(35.8) Min	.13 (3.2)	.73 (18.4)	1.97 (50.0) 1.93 (49.0)
MPM1421***7***	∅ 24.000(9449) 23.988(9444)	7.998(3149) 7.963(3135)	19.91(.784)	37.0(1.46) Min	3.6 (.14)	18.0 (.71)	50.5 (1.99) 49.5 (1.95)
MPM1422***6***	∅ .8750(22.225) .8745(22.212)	.1890(4.801) .1875(4.763)	.774(19.66)	1.41(35.8) Min	.13 (3.2)	.73 (18.4)	1.97 (50.0) 1.93 (49.0)
MPM1422***7***	∅ 24.000(9449) 23.988(9444)	7.998(3149) 7.963(3135)	19.91(.784)	37.0(1.46) Min	3.6 (.14)	18.0 (.71)	50.5 (1.99) 49.5 (1.95)
MPM1423***6***	∅ .8750(22.225) .8745(22.212)	.1890(4.801) .1875(4.763)	.774(19.66)	1.41(35.8) Min	.13 (3.2)	.73 (18.4)	1.97 (50.0) 1.93 (49.0)
MPM1423***7***	∅ 31.999(1.2598) 31.986(1.2593)	10.000(.3937) 9.964(.3923)	26.90(1.059)	37.0(1.46) Min	3.6 (.14)	18.0 (.71)	50.5 (1.99) 49.5 (1.95)
MPM1424***6***	∅ .8750(22.225) .8745(22.212)	.1890(4.801) .1875(4.763)	.774(19.66)	1.41(35.8) Min	.13 (3.2)	.73 (18.4)	1.97 (50.0) 1.93 (49.0)
MPM1424***7***	∅ 31.999(1.2598) 31.986(1.2593)	10.000(.3937) 9.964(.3923)	26.90(1.059)	37.0(1.46) Min	3.6 (.14)	18.0 (.71)	50.5 (1.99) 49.5 (1.95)

Model	"H"	"J"	"K"	"L"	"L" w/ Brake	"M"	"N"
MPM1421***6***	3.7(95)Max	1.74(44.1)	3/8-16UNC-2BTHRU (4)EQ SPD AS SHOWN ON Ø5.875(149.22) B.C.	11.31(287.3)Max	14.01(355.9)Max	∅ 4.500(114.30) 4.499(114.27)	□ 5.59(142.0)
MPM1421***7***	95(3.7)Max	44.1(1.74)	∅11.00(.433)THRU (4)EQ SPD AS SHOWN ON Ø165.00(6.496) B.C.	286.8(11.29)Max	355.3(13.99)Max	∅ 130.00(5.118) 129.97(5.117)	□ 142.0(5.59)
MPM1422***6***	3.7(95)Max	1.74(44.1)	3/8-16UNC-2BTHRU (4)EQ SPD AS SHOWN ON Ø5.875(149.22) B.C.	14.01(355.9)Max	16.71(424.4)Max	∅ 4.500(114.30) 4.499(114.27)	□ 5.59(142.0)
MPM1422***7***	95(3.7)Max	44.1(1.74)	∅11.00(.433)THRU (4)EQ SPD AS SHOWN ON Ø165.00(6.496) B.C.	355.3(13.99)Max	423.9(16.69)Max	∅ 130.00(5.118) 129.97(5.117)	□ 142.0(5.59)
MPM1423***6***	3.7(95)Max	1.74(44.1)	3/8-16UNC-2BTHRU (4)EQ SPD AS SHOWN ON Ø5.875(149.22) B.C.	16.71(424.4)Max	19.41(493.0)Max	∅ 4.500(114.30) 4.499(114.27)	□ 5.59(142.0)
MPM1423***7***	95(3.7)Max	44.1(1.74)	∅11.00(.433)THRU (4)EQ SPD AS SHOWN ON Ø165.00(6.496) B.C.	423.9(16.69)Max	492.5(19.39)Max	∅ 130.00(5.118) 129.97(5.117)	□ 142.0(5.59)
MPM1424***6***	3.7(95)Max	1.74(44.1)	3/8-16UNC-2BTHRU (4)EQ SPD AS SHOWN ON Ø5.875(149.22) B.C.	19.41(493.0)Max	22.11(561.6)Max	∅ 4.500(114.30) 4.499(114.27)	□ 5.59(142.0)
MPM1424***7***	95(3.7)Max	44.1(1.74)	∅11.00(.433)THRU (4)EQ SPD AS SHOWN ON Ø165.00(6.496) B.C.	492.5(19.39)Max	561.1(22.09)Max	∅ 130.00(5.118) 129.97(5.117)	□ 142.0(5.59)

English = 6 Units: in (mm)  
 Metric = 7 Units: mm (in)

For Mechanical Dimensions on Termination Option 2 Consult Factory.

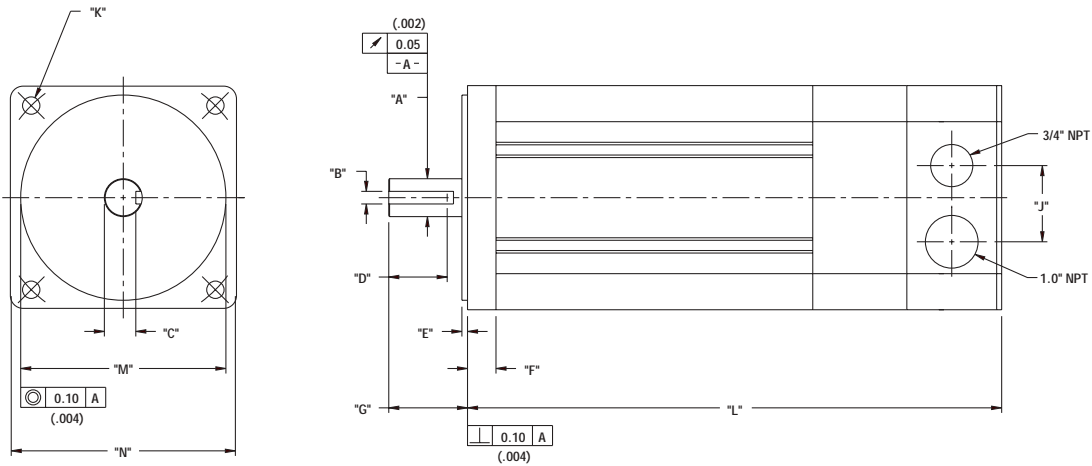

**6" (142) English and Metric NPT Termination-Option 3 Motors**

Model	"A"	"B"	"C"	"D"	"E"	"F"	"G"
MPM1421***6***	∅ .8750(22.225) ∅ .8745(22.212)	.1890(4.801) .1875(4.763)	.774(19.66)	1.41(35.8) Min	.13(3.2)	.73(18.4)	1.97(50.0) 1.93(49.0)
MPM1421***7***	∅ 24.00(9449) ∅ 23.988(9444)	7.998(3149) 7.963(3135)	19.91(.784)	37.0(1.46) Min	3.6(.14)	18.0(.71)	50.4(1.98) 49.4(1.94)
MPM1422***6***	∅ .8750(22.225) ∅ .8745(22.212)	.1890(4.801) .1875(4.763)	.774(19.66)	1.41(35.8) Min	.13(3.2)	.73(18.4)	1.97(50.0) 1.93(49.0)
MPM1422***7***	∅ 24.00(9449) ∅ 23.988(9444)	7.998(3149) 7.963(3135)	19.91(.784)	37.0(1.46) Min	3.6(.14)	18.0(.71)	50.4(1.98) 49.4(1.94)
MPM1423***6***	∅ .8750(22.225) ∅ .8745(22.212)	.1890(4.801) .1875(4.763)	.774(19.66)	1.41(35.8) Min	.13(3.2)	.73(18.4)	1.97(50.0) 1.93(49.0)
MPM1423***7***	∅ 31.999(1.2598) ∅ 31.986(1.2593)	10.000(.3937) 9.964(.3923)	26.90(1.059)	37.0(1.46) Min	3.6(.14)	18.0(.71)	50.4(1.98) 49.4(1.94)
MPM1424***6***	∅ .8750(22.225) ∅ .8745(22.212)	.1890(4.801) .1875(4.763)	.774(19.66)	1.41(35.8) Min	.13(3.2)	.73(18.4)	1.97(50.0) 1.93(49.0)
MPM1424***7***	∅ 31.999(1.2598) ∅ 31.986(1.2593)	10.000(.3937) 9.964(.3923)	26.90(1.059)	37.0(1.46) Min	3.6(.14)	18.0(.71)	50.4(1.98) 49.4(1.94)

Model	"J"	"K"	"L"	"L" w/ Brake	"M"	"N"
MPM1421***6***	1.90(48.3)	3/8-16UNC-2BTHRU (4)EQ SPD AS SHOWN ON ∅5.875(149.22) B.C.	13.37(339.6) Max	16.07(408.2) Max	∅ 4.500(114.30) ∅ 4.499(114.27)	□ 5.59(142.0)
MPM1421***7***	48.3(1.90)	∅11.00(.433)THRU (4)EQ SPD AS SHOWN ON ∅165.00(6.496) B.C.	339.0(13.35) Max	408.0(16.05) Max	∅ 130.00(5.118) ∅ 129.97(5.117)	□ 142.0(5.59)
MPM1422***6***	1.90(48.3)	3/8-16UNC-2BTHRU (4)EQ SPD AS SHOWN ON ∅5.875(149.22) B.C.	16.07(408.2) Max	18.77(476.8) Max	∅ 4.500(114.30) ∅ 4.499(114.27)	□ 5.59(142.0)
MPM1422***7***	48.3(1.90)	∅11.00(.433)THRU (4)EQ SPD AS SHOWN ON ∅165.00(6.496) B.C.	408.0(16.05) Max	477.0(18.75) Max	∅ 130.00(5.118) ∅ 129.97(5.117)	□ 142.0(5.59)
MPM1423***6***	1.90(48.3)	3/8-16UNC-2BTHRU (4)EQ SPD AS SHOWN ON ∅5.875(149.22) B.C.	18.77(476.8) Max	21.47(545.3) Max	∅ 4.500(114.30) ∅ 4.499(114.27)	□ 5.59(142.0)
MPM1423***7***	48.3(1.90)	∅11.00(.433)THRU (4)EQ SPD AS SHOWN ON ∅165.00(6.496) B.C.	477.0(18.75) Max	546.0(21.45) Max	∅ 130.00(5.118) ∅ 129.97(5.117)	□ 142.0(5.59)
MPM1424***6***	1.90(48.3)	3/8-16UNC-2BTHRU (4)EQ SPD AS SHOWN ON ∅5.875(149.22) B.C.	21.47(545.3) Max	24.17(613.9) Max	∅ 4.500(114.30) ∅ 4.499(114.27)	□ 5.59(142.0)
MPM1424***7***	48.3(1.90)	∅11.00(.433)THRU (4)EQ SPD AS SHOWN ON ∅165.00(6.496) B.C.	546.0(21.45) Max	613.3(24.15) Max	∅ 130.00(5.118) ∅ 129.97(5.117)	□ 142.0(5.59)

English = 6 Units: in (mm)  
 Metric = 7 Units: mm (in)

For Mechanical Dimensions on Termination Option 2 Consult Factory.

**Custom Designed Servo Motors For Your Specific Application. Call 1-800-358-9070 Today.**

**6" Motor with Resolver Feedback**

**Option 1**

Motor Connector 270-00017(SG3102E-22-22P(027))

Pin	Function
A	$\phi$ R
B	$\phi$ S
C	$\phi$ T
D	PE GND

Resolver Connector 270-00024(PT02E-14-18P(027))

Pin	Function
U	THERM
N	THERM
H	SIN
G	COS GND
S	COS
F	SIN GND
R	REF GND
E	REF
D	RES SHLD
P	GND
*A	BRK (+)
*B	BRK (-)
*C	BRK SHLD
J	-
K	-
L	-
M	-
T	-

\*USE ONLY WITH BRAKE OPTION

**Option 2**

Motor Connector 270-00325 (CEGA258NN0000001000)

Pin	Function
U	$\phi$ R(U1)
V	$\phi$ S(V1)
W	$\phi$ T(W1)
PE	PE GND
*+	BRK (+)
*-	BRK (-)
1	THERM
2	THERM

\*USE ONLY WITH BRAKE OPTION

Resolver Connector 270-00257(AEGA052NN00000013000)

Pin	Function
1	-
2	REF (R1)
3	REF GND (R2)
4	COS GND (S1)
5	COS (S3)
6	SIN (S2)
7	SIN GND (S4)
8	-
9	-
10	-
11	-
12	-

**Option 3**

Connection Chart (NPT) Resolver

Terminal	Function	Connection
1	$\phi$ R	TB3 (MOTOR CONN)
2	$\phi$ S	
3	$\phi$ T	
4	PE GND	
*S11	BRK (+)	TB2 (BRAKE CONN)
*S10	BRK (-)	
S9	REF GND	TB1 (RESOLVER & THERM CONN)
S8	REF	
S7	SIN	
S6	COS	
S5	COS GND	
S4	SIN GND	
S3	THERM	
S2	THERM	
S1	RES SHLD	

\*USE ONLY WITH BRAKE OPTION

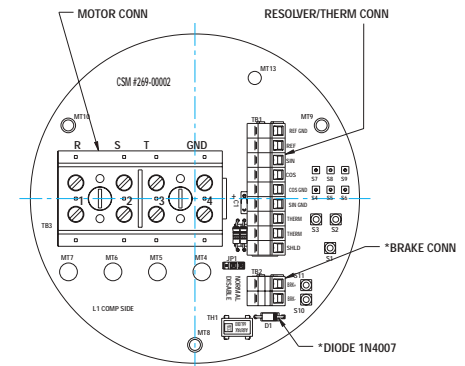



**6" Motor with Encoder Feedback**

**Option 1**

Motor Connector 270-00017 (SG3102E-22-22P(027))	
Pin	Function
A	$\phi$ R
B	$\phi$ S
C	$\phi$ T
D	PE GND



Encoder Connector 270-00024 (PT02E-14-18P(027))	
Pin	Function
T	GROUND
K	+5VDC
B	CH A
C	CH A\
N	CH B
P	CH B\
M	CH Z
U	CH Z\
E	CH U
R	CH U\
F	CH V
S	CH V\
G	CH W
H	CH W\
D	GND/CABLE
A	THERM
L	THERM
J	GND

**Option 1 with brake**

Encoder Brake Connector 270-00219 (PT02E-16-23P(027))	
Pin	Function
T	GROUND
K	+5VDC
B	CH A
C	CH A\
N	CH B
P	CH B\
M	CH Z
U	CH Z\
E	CH U
R	CH U\
F	CH V
S	CH V\
G	CH W
H	CH W\
D	GND/CABLE
A	THERM
L	THERM
J	GND
V*	BRK (+) 
W*	BRK (-) 
X*	BRK SHLD
Y	-
Z	-

\* Use only with Brake option

**Option 2**

Motor Connector 270-00325 (CEGA258NN0000001000)	
Pin	Function
U	$\phi$ R(U1)
PE	PE GND
W	$\phi$ S(W1)
V	$\phi$ T(V1)
*+	BRK (+) 
*-	BRK (-) 
1	THERM
2	THERM

\* USE ONLY WITH BRAKE OPTION

Motor Connector 270-00257 (AEGA052NN00000013000)	
Pin	Function
1	GND(OV)
2	CH A(A)
3	CH A(A\)
4	CH B(B)
5	CH B(B\)
6	CH Z(Z)
7	CH Z(Z\)
8	+5V(+5V)
9	-
10	CH U(RLG U)
11	CH V(RLG V)
12	CH W(RLG W)

**Option 3-Consult Factory**

Custom Designed Servo Motors For Your Specific Application. Call 1-800-358-9070 Today.

# 8" Frame Brushless Servo Motors



## Motor Data (Sine)

Motor Parameters		Units	1901ASG****	1901BSG****	1902ASG****
Horsepower	Hp Rated	Hp	6.0	3.0	11.9
Kilowatts	KW Rated	KW	4.5	2.2	8.9
Max. Operating Speed	N Max	RPM	2500	1250	2500
Speed @ Rated Torque	N Rated	RPM	1800	750	2000
*Continuous Rated Torque @ Rated Speed		IN-LBS[Nm]	209 [23.6]	250 [28.2]	375 [42.4]
*Continuous Stall Torque		IN-LBS[Nm]	280 [31.9]	280 [31.6]	600 [67.8]
Continuous Line Current		AMPS	22.0	10.7	47.2
Peak Torque	Tpk	IN-LBS[Nm]	746 [84.3]	625 [70.6]	1800 [203.0]
Peak Current		AMPS	58.7	23.8	141.6
Max. Theoretical Accel.		RAD/SEC <sup>2</sup>	18,195	15,244	23,077
Torque Sensitivity		Kt	12.7 [1.44]	26.21 [2.96]	12.71 [1.44]
Back EMF (Line to Line)		±10% Vrms/Krpm	80	165	80
D.C.Resistance (P-P)		±10% OHMS	.31	1.36	11
Inductance (P-P)		±10% MILLIHENRIES	3.70	15.5	.65
Rotor Inertia		Jm	.0411[.00464]	.0411[.00464]	.0714[.00807]
Static Friction		Tf	8.2[.92]	8.2[.92]	9.8[1.1]
Motor Weight		LBS[Kg]	67[30.4]	67[30.4]	98[44.5]
Line Voltage		VAC	230	230	230

Motor Parameters		Units	1902BSG****	1904ASG****	1904BSG****
Horsepower	Hp Rated	Hp	6.7	17.5	10.8
Kilowatts	KW Rated	KW	5.0	13.0	8.0
Max. Operating Speed	N Max	RPM	1250	2250	1250
Speed @ Rated Torque	N Rated	RPM	850	2000	1000
*Continuous Rated Torque @ Rated Speed		IN-LBS[Nm]	500 [56.5]	550 [62.1]	680 [76.8]
*Continuous Stall Torque		IN-LBS[Nm]	600 [67.8]	820 [92.7]	820 [92.7]
Continuous Line Current		AMPS	23.5	58.7	32.1
Peak Torque	Tpk	IN-LBS[Nm]	1560 [176.3]	3000 [339.0]	3000 [339.0]
Peak Current		AMPS	61.0	214.5	117
Max. Theoretical Accel.		RAD/SEC <sup>2</sup>	20,000	22,556	22,556
Torque Sensitivity		Kt	25.58 [2.89]	13.98 [1.58]	25.58 [2.89]
Back EMF (Line to Line)		±10% Vrms/Krpm	161	88	161
D.C.Resistance (P-P)		±10% OHMS	.44	.05	.19
Inductance (P-P)		±10% MILLIHENRIES	6.8	96	3.2
Rotor Inertia		Jm	.0714[.00807]	.133[.0150]	.133[.0150]
Static Friction		Tf	9.8[1.1]	13.0[1.5]	13.0[1.5]
Motor Weight		LBS[Kg]	98[44.5]	160[72.6]	160[72.6]
Line Voltage		VAC	230	230	230

### Brake Info:

Min. Holding Torque: 90FT-LBS  
 Input Voltage: 24VDC  
 Current : 1.4AMPS  
 Inertia : .0085 IN-LB-SEC<sup>2</sup>  
 Weight Adder: 18LBS

\*25° C Ambient with a maximum case temperature of 100° C on motor. Motor mounted on a 14" x 14" x 3/4" aluminum heatsink. Thermostat in stator windings will open if winding temperature exceeds 155° C. This allows for an approximate +10% headroom in the continuous torque rating before thermostat opens.

### Mechanical Notes:

1. Axial Load: 100 LBS. Max.
2. Radial Load: 250 LBS. Max. @ 1" from face
3. Motor Sealed to IP65

**Motor Data (Trap)**

Motor Parameters		Units	1901ATG****	1901BTG****	1902ATG****
Horsepower	Hp Rated	Hp	6.0	3.0	11.4
Kilowatts	KW Rated	KW	4.5	2.2	8.9
Max. Operating Speed	N Max	RPM	2500	1250	2500
Speed @ Rated Torque	N Rated	RPM	1800	750	2000
*Continuous Rated Torque @ Rated Speed		IN-LBS[Nm]	209 [23.6]	250 [28.2]	375 [42.4]
*Continuous Stall Torque		IN-LBS[Nm]	280 [31.9]	280 [31.6]	600 [67.8]
Continuous Line Current		AMPS	31.15	15.10	66.7
Peak Torque	Tpk	IN-LBS[Nm]	746 [84.3]	625 [70.6]	1800 [203.0]
Peak Current		AMPS	82.98	33.71	200
Max. Theoretical Accel.		RAD/SEC <sup>2</sup>	18,195	15,244	23,077
Torque Sensitivity	Kt	IN-LBS/AMP[Nm/AMP]	8.99 [1.02]	18.54 [2.09]	8.99 [10.02]
Back EMF (Line to Line)	±10%	Vrms/Krpm	80	165	80
D.C.Resistance (P-P)	±10%	OHMS	.31	1.36	11
Inductance (P-P)	±10%	MILLIHENRIES	3.70	15.5	1.65
Rotor Inertia	Jm	IN-LBS-SEC <sup>2</sup> [Kg-M <sup>2</sup> ]	.0411[.00464]	.0411[.00464]	.0714[.00807]
Static Friction	Tf	IN-LBS[Nm]	8.2[.92]	8.2[.92]	9.8[1.1]
Motor Weight		LBS[Kg]	67[30.4]	67[30.4]	98[44.5]
Line Voltage		VAC	230	230	230

Motor Parameters		Units	1902BTG****	1904ATG****	1904BTG****
Horsepower	Hp Rated	Hp	6.7	17.5	10.8
Kilowatts	KW Rated	KW	5.0	13.0	8.0
Max. Operating Speed	N Max	RPM	1250	2250	1250
Speed @ Rated Torque	N Rated	RPM	850	2000	1000
*Continuous Rated Torque @ Rated Speed		IN-LBS[Nm]	500 [56.5]	550 [62.1]	680 [76.8]
*Continuous Stall Torque		IN-LBS[Nm]	600 [67.8]	820 [92.7]	820 [92.7]
Continuous Line Current		AMPS	33	82.9	45.3
Peak Torque	Tpk	IN-LBS[Nm]	1560 [176.3]	3000 [339.0]	3000 [339.0]
Peak Current		AMPS	86.2	303	166
Max. Theoretical Accel.		RAD/SEC <sup>2</sup>	21,849	22,556	22,556
Torque Sensitivity	Kt	IN-LBS/AMP[Nm/AMP]	18.09 [2.04]	9.89 [1.12]	18.09 [2.04]
Back EMF (Line to Line)	±10%	Vrms/Krpm	161	88	161
D.C.Resistance (P-P)	±10%	OHMS	.44	05	.19
Inductance (P-P)	±10%	MILLIHENRIES	6.8	96	3.2
Rotor Inertia	Jm	IN-LBS-SEC <sup>2</sup> [Kg-M <sup>2</sup> ]	.0714[.00807]	.133[.0150]	.133[.0150]
Static Friction	Tf	IN-LBS[Nm]	9.8[1.1]	13.0[1.5]	13.0[1.5]
Motor Weight		LBS[Kg]	98[44.5]	160[72.6]	160[72.6]
Line Voltage		VAC	230	230	230

**Brake Info:**

Min. Holding Torque: 90FT-LBS  
 Input Voltage: 24VDC  
 Current : 1.4AMPS  
 Inertia: .0085 IN-LB-SEC<sup>2</sup>  
 Weight Adder: 18LBS

\*25° C Ambient with a maximum case temperature of 100° C on motor. Motor mounted on a 14" x 14" x 3/4" aluminum heatsink. Thermostat in stator windings will open if winding temperature exceeds 155° C. This allows for an approximate +10% headroom in the continuous torque rating before thermostat opens.

- Mechanical Notes:
1. Axial Load: 100 LBS. Max.
  2. Radial Load: 250 LBS. Max. @ 1" from face
  3. Motor Sealed to IP65

**Custom Designed Servo Motors For Your Specific Application. Call 1-800-358-9070 Today.**

**Motor Data (Sine)**

Motor Parameters		Units	1901CSJ****	1901DSJ****	1902CSJ****
Horsepower	Hp Rated	Hp	6.2	3.4	11.9
Kilowatts	KW Rated	KW	4.6	2.6	8.9
Max. Operating Speed	N Max	RPM	2500	1300	2500
Speed @ Rated Torque	N Rated	RPM	1900	900	2000
*Continuous Rated Torque @ Rated Speed		IN-LBS[Nm]	205 [23.2]	240 [27.1]	375 [42.4]
*Continuous Stall Torque		IN-LBS[Nm]	280 [31.6]	280 [31.6]	600 [67.8]
Continuous Line Current		AMPS	10.7	5.5	23.58
Peak Torque	Tpk	IN-LBS[Nm]	830 [93.8]	780 [88.1]	1800 [203.4]
Peak Current		AMPS	31.7	15.4	70.4
Max. Theoretical Accel.		RAD/SEC <sup>2</sup>	20,244	19,024	23,077
Torque Sensitivity	Kt	IN-LBS/AMP[Nm/AMP]	26.21 [2.96]	50.52 [5.71]	25.58 [2.89]
Back EMF (Line to Line)	±10%	Vrms/Krpm	165	318	161
D.C.Resistance (P-P)	±10%	OHMS	1.4	4.6	.44
Inductance (P-P)	±10%	MILLIHENRIES	15.5	60.2	6.8
Rotor Inertia	Jm	IN-LBS-SEC <sup>2</sup> [Kg-M <sup>2</sup> ]	.0411[.00464]	.0411[.00464]	.0714[.00807]
Static Friction	Tf	IN-LBS[Nm]	8.2[.92]	8.2[.92]	9.8[1.1]
Motor Weight		LBS[Kg]	67[30.4]	67[30.4]	98[44.5]
Line Voltage		VAC	460	460	460

Motor Parameters		Units	1902DSJ****	1904CSJ****	1904DSJ****
Horsepower	Hp Rated	Hp	6.4	18.1	11.2
Kilowatts	KW Rated	KW	4.8	13.5	8.4
Max. Operating Speed	N Max	RPM	1230	2500	1250
Speed @ Rated Torque	N Rated	RPM	800	2150	1050
*Continuous Rated Torque @ Rated Speed		IN-LBS[Nm]	505 [57.1]	530 [59.9]	675 [76.3]
*Continuous Stall Torque		IN-LBS[Nm]	600 [67.8]	820 [92.7]	820 [92.7]
Continuous Line Current		AMPS	11.5	32.1	16
Peak Torque	Tpk	IN-LBS[Nm]	1440 [162.7]	3000 [339]	3000 [339]
Peak Current		AMPS	27.5	117	59
Max. Theoretical Accel.		RAD/SEC <sup>2</sup>	18,462	22,556	22,556
Torque Sensitivity	Kt	IN-LBS/AMP[Nm/AMP]	52.3 [5.91]	25.58 [2.89]	51.16 [5.78]
Back EMF (Line to Line)	±10%	Vrms/Krpm	329	161	322
D.C.Resistance (P-P)	±10%	OHMS	2.0	19	.72
Inductance (P-P)	±10%	MILLIHENRIES	29.3	3.2	13.4
Rotor Inertia	Jm	IN-LBS-SEC <sup>2</sup> [Kg-M <sup>2</sup> ]	.0714[.0807]	.133[.0150]	.133[.0150]
Static Friction	Tf	IN-LBS[Nm]	9.8[1.1]	13.0[1.5]	13.0[1.5]
Motor Weight		LBS[Kg]	98[44.5]	160[72.6]	160[72.6]
Line Voltage		VAC	460	460	460

**Brake Info:**

Min. Holding Torque: 90FT-LBS  
 Input Voltage: 24VDC  
 Current : 1.4AMPS  
 Inertia: .0085 IN-LB-SEC<sup>2</sup>  
 Weight Adder: 18LBS

\*25° C Ambient with a maximum case temperature of 100° C on motor. Motor mounted on a 14" x 14" x 3/4" aluminum heatsink. Thermostat in stator windings will open if winding temperature exceeds 155° C. This allows for an approximate +10% headroom in the continuous torque rating before thermostat opens.

- Mechanical Notes:
1. Axial Load: 100 LBS. Max.
  2. Radial Load: 250 LBS. Max. @ 1" from face
  3. Motor Sealed to IP65

**Motor Data (Trap)**

Motor Parameters			Units	1901CTJ****	1901DTJ****	1902CTJ****
Horsepower	Hp Rated	Hp		6.2	3.4	11.9
Kilowatts	KW Rated	KW		4.6	2.6	8.9
Max. Operating Speed	N Max	RPM		2500	1300	2500
Speed @ Rated Torque	N Rated	RPM		1900	900	2000
*Continuous Rated Torque @ Rated Speed		IN-LBS[Nm]		205 [23.2]	240 [27.1]	375 [42.4]
*Continuous Stall Torque		IN-LBS[Nm]		280 [31.6]	280 [31.6]	600 [67.8]
Continuous Line Current		AMPS		15.1	7.8	33.17
Peak Torque	Tpk	IN-LBS[Nm]		830 [93.8]	780 [88.1]	1800 [203.4]
Peak Current		AMPS		44.8	21.8	99.5
Max. Theoretical Accel.		RAD/SEC <sup>2</sup>		20,244	19,024	23,077
Torque Sensitivity	Kt	IN-LBS/AMP[Nm/AMP]		18.53 [2.05]	35.73 [4.04]	18.09 [2.04]
Back EMF (Line to Line)	±10%	Vrms/Krpm		165	318	161
D.C. Resistance (P-P)	±10%	OHMS		1.4	4.6	.44
Inductance (P-P)	±10%	MILLIHENRIES		15.5	60.2	6.8
Rotor Inertia	Jm	IN-LBS-SEC <sup>2</sup> [Kg-M <sup>2</sup> ]		.0411[.00464]	.0411[.00464]	.0714[.00807]
Static Friction	Tf	IN-LBS[Nm]		8.2[.92]	8.2[.92]	9.8[1.1]
Motor Weight		LBS[Kg]		67[30.4]	67[30.4]	98[44.5]
Line Voltage		VAC		460	460	460

Motor Parameters			Units	1902DTJ****	1904CTJ****	1904DTJ****
Horsepower	Hp Rated	Hp		6.4	18.1	11.2
Kilowatts	KW Rated	KW		4.8	13.5	8.4
Max. Operating Speed	N Max	RPM		1230	2500	1250
Speed @ Rated Torque	N Rated	RPM		800	2150	1050
*Continuous Rated Torque @ Rated Speed		IN-LBS[Nm]		505 [57.1]	530 [59.9]	675 [76.3]
*Continuous Stall Torque		IN-LBS[Nm]		600 [67.8]	820 [92.7]	820 [92.7]
Continuous Line Current		AMPS		16.2	45.4	22.7
Peak Torque	Tpk	IN-LBS[Nm]		1440 [162.7]	3000 [339]	3000 [339]
Peak Current		AMPS		38.9	166	83.0
Max. Theoretical Accel.		RAD/SEC <sup>2</sup>		18,462	22,556	22,556
Torque Sensitivity	Kt	IN-LBS/AMP[Nm/AMP]		37 [4.18]	18.09 [2.04]	36.18 [4.09]
Back EMF (Line to Line)	±10%	Vrms/Krpm		329	161	322
D.C. Resistance (P-P)	±10%	OHMS		2.0	19	.72
Inductance (P-P)	±10%	MILLIHENRIES		29.3	3.2	13.4
Rotor Inertia	Jm	IN-LBS-SEC <sup>2</sup> [Kg-M <sup>2</sup> ]		.0714[.0807]	.133[.0150]	.133[.0150]
Static Friction	Tf	IN-LBS[Nm]		9.8[1.1]	13.0[1.5]	13.0[1.5]
Motor Weight		LBS[Kg]		98[44.5]	160[72.6]	160[72.6]
Line Voltage		VAC		460	460	460

**Brake Info:**

Min. Holding Torque: 90FT-LBS  
 Input Voltage: 24VDC  
 Current : 1.4AMPS  
 Inertia : .0085 IN-LB-SEC<sup>2</sup>  
 Weight Adder: 18LBS

\*25° C Ambient with a maximum case temperature of 100° C on motor. Motor mounted on a 14" x 14" x 3/4" aluminum heatsink. Thermostat in stator windings will open if winding temperature exceeds 155° C. This allows for an approximate +10% headroom in the continuous torque rating before thermostat opens.

**Mechanical Notes:**

1. Axial Load: 100 LBS. Max.
2. Radial Load: 250 LBS. Max. @ 1" from face
3. Motor Sealed to IP65

**Custom Designed Servo Motors For Your Specific Application. Call 1-800-358-9070 Today.**

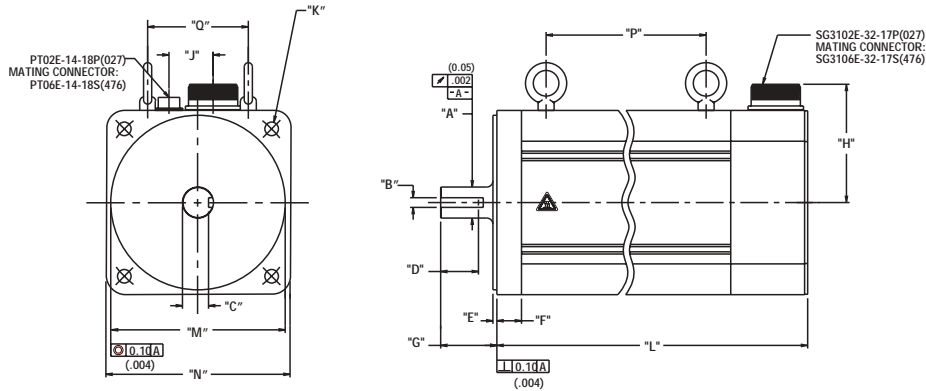

**8" (190) Metric Connectorized Termination-Option 1 Motors**

Model	"A"	"B"	"C"	"D"	"E"	"F"	"G"	"H"
MPM1901***7***	32.017(1.2605) ∅ 31.999(1.2598)	10.000(.3937) 9.964(.3923)	26.90(1.059)	39.0(1.54) Min	4.0(0.16)	25.4(1.00)	58.5(2.30) 57.5(2.26)	123.0(4.84)
MPM1902***7***	32.017(1.2605) ∅ 31.999(1.2598)	10.000(.3937) 9.964(.3923)	26.90(1.059)	39.0(1.54) Min	4.0(0.16)	25.4(1.00)	58.5(2.30) 57.5(2.26)	123.0(4.84)
MPM1904***7***	48.019(1.8905) ∅ 47.998(1.8897)	14.000(.5512) 13.957(.5495)	42.39(1.669)	39.0(1.54) Min	4.0(0.16)	25.4(1.00)	58.5(2.30) 57.5(2.26)	123.0(4.84)

Model	J"	"K"	"L"	"L" w/ Brake	"M"	"N"	"P"	"Q"
MPM1901***7***	45.5(1.79)	∅14.00(.551)THRU (4)EQ SPD AS SHOWN ON ∅215.00(8.464) B.C.	321.2(12.65)Max	397.5(15.65)Max	∅ 180.01(7.087) 179.99(7.086)	□ 190.0(7.48)	165.1(6.50)	103.9(4.09)
MPM1902***7***	45.5(1.79)	∅14.00(.551)THRU (4)EQ SPD AS SHOWN ON ∅215.00(8.464) B.C.	397.5(15.65)Max	473.7(18.65)Max	∅ 180.01(7.087) 179.99(7.086)	□ 190.0(7.48)	241.3(9.50)	103.9(4.09)
MPM1904***7***	45.5(1.79)	∅14.00(.551)THRU (4)EQ SPD AS SHOWN ON ∅215.00(8.464) B.C.	549.9(21.65)Max	626.1(24.65)Max	∅ 180.01(7.087) 179.99(7.086)	□ 190.0(7.48)	393.7(15.50)	103.9(4.09)

Metric = 7 Units: mm (in) For Mechanical Dimensions on Termination Option 2 Consult Factory.  
 Option 6-Not Available  
 Custom Mounts-Consult Factory

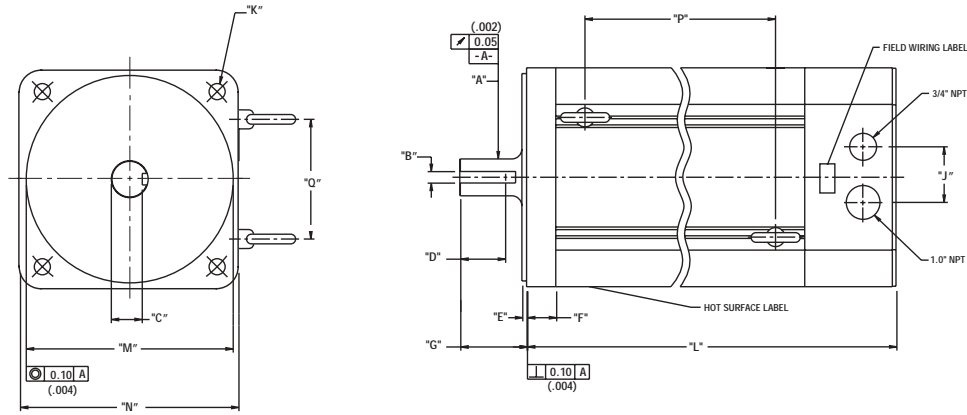

**8" (190) Metric NPT Termination-Option 3 Motors**

Model	"A"	"B"	"C"	"D"	"E"	"F"	"G"
MPM1901***7***	∅ 32.017(1.2605) 31.999(1.2598)	10.000(.3937) 9.964(.3923)	26.90(1.059)	39.0(1.54)Min	4.0(0.16)	25.4(1.00)	58.5(2.30) 57.5(2.26)
MPM1902***7***	∅ 32.018(1.2605) 31.998(1.2598)	10.000(.3937) 9.964(.3923)	26.90(1.059)	39.0(1.54)Min	4.0(0.16)	25.4(1.00)	58.5(2.30) 57.5(2.26)
MPM1904***7***	∅ 48.019(1.8905) 47.998(1.8897)	14.000(.5512) 13.957(.5495)	42.39(1.669)	39.0(1.54)Min	4.0(0.16)	25.4(1.00)	58.5(2.30) 57.5(2.26)

Model	"J"	"K"	"L"	"L" w/ Brake	"M"	"N"	"P"	"Q"
MPM1901***7***	48.3(1.90)	∅14.00(.551)THRU (4)EQ SPD AS SHOWN ON ∅215.00(8.464) B.C.	321.2(12.65)Max	397.5(15.65)Max	∅ 180.01(7.087) 179.99(7.086)	□ 190.0(7.48)	165.1(6.50)	103.9(4.09)
MPM1902***7***	48.3(1.90)	∅14.00(.551)THRU (4)EQ SPD AS SHOWN ON ∅215.00(8.464) B.C.	397.5(15.65)Max	473.7(18.65)Max	∅ 180.01(7.087) 179.99(7.086)	□ 190.0(7.48)	241.3(9.50)	103.9(4.09)
MPM1904***7***	48.3(1.90)	∅14.00(.551)THRU (4)EQ SPD AS SHOWN ON ∅215.00(8.464) B.C.	549.9(21.65)Max	626.1(24.65)Max	∅ 180.01(7.087) 179.99(7.086)	□ 190.0(7.48)	393.7(15.50)	103.9(4.09)

Metric = 7 Units: mm (in) For Mechanical Dimensions on Termination Option 2 Consult Factory.  
 Option 6-Not Available  
 Custom Mounts-Consult Factory

**Custom Designed Servo Motors For Your Specific Application. Call 1-800-358-9070 Today.**

**8" Motor with Resolver Feedback**

**Option 1**

**Motor Connector 270-00066 (SG3102E-32-17P(027))**

Pin	Function
A	$\phi R$
B	$\phi S$
C	$\phi T$
D	PE GND

**Resolver Connector 270-00024(PT02E-14-18P(027))**

Pin	Function
U	THERM
N	THERM
H	SIN
G	COS GND
S	COS
F	SIN GND
R	REF GND
E	REF
D	RES SHLD
P	GND
*A	BRK (+)
*B	BRK (-)
*C	BRK SHLD
J	-
K	-
L	-
M	-
T	-

\*USE ONLY WITH BRAKE OPTION

**Option 2**

**Motor Connector 270-00352 (FECF08CMRAB000)**

Pin	Function
U	$\phi R(U1)$
V	$\phi S(V1)$
W	$\phi T(W1)$
PE	PE GND
*+	BRK (+)
*-	BRK (-)
1	THERM
2	THERM

\*USE ONLY WITH BRAKE OPTION

**Resolver Connector 270-00257 (AEGA052NN00000013000)**

Pin	Function
1	-
2	REF (R1)
3	REF GND (R2)
4	COS GND (S1)
5	COS (S3)
6	SIN (S2)
7	SIN GND (S4)
8	-
9	-
10	-
11	-
12	-

**Option 3**

**Connection Chart (NPT) Resolver**

Terminal	Function
1	$\phi R$
2	$\phi S$
3	$\phi T$
-	PE GND
*S11	BRK (+)
*S10	BRK (-)
S9	REF GND
S8	REF
S7	SIN
S6	COS
S5	COS GND
S4	SIN GND
S3	THERM
S2	THERM
S1	RES SHLD

\*USE ONLY WITH BRAKE OPTION

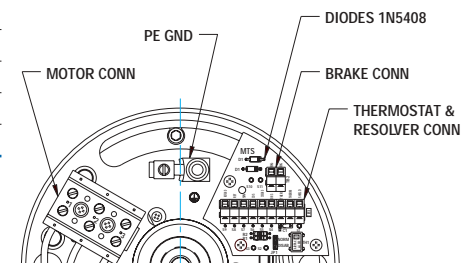

**8" Motor with Encoder Feedback**

**Option 1**

**Motor Connector 270-00066 (SG3102E-32-17P(027))**



Pin	Function
A	$\phi$ R
B	$\phi$ S
C	$\phi$ T
D	PE GND

**Encoder Connector 270-00024(PT02E-14-18P(027))**

Pin	Function
T	GROUND
K	+5VDC
B	CH A
C	CH A\
N	CH B
P	CH B\
M	CH Z
U	CH Z\
E	CH U
R	CH U\
F	CH V
S	CH V\
G	CH W
H	CH W\
D	GND/CABLE
A	THERM
L	THERM
J	GND

**Option 1 with brake**



**Encoder Brake Connector 270-00219 (PT02E-16-23P(027))**

Pin	Function
T	GROUND
K	+5VDC
B	CH A
C	CH A\
N	CH B
P	CH B\
M	CH Z
U	CH Z\
E	CH U
R	CH U\
F	CH V
S	CH V\
G	CH W
H	CH W\
D	GND/CABLE
A	THERM
L	THERM
J	GND
V*	BRK (+) 
W*	BRK (-) 
X*	BRK SHLD
Y	-
Z	-

\*USE ONLY WITH BRAKE OPTION

**Option 2**

**Motor Connector 270-00352 (FECF08CMRAB000)**

Pin	Function
U	$\phi$ R(U1)
PE	PE GND
W	$\phi$ S(W1)
V	$\phi$ T(V1)
*+	BRK (+) 
*-	BRK (-) 
1	THERM
2	THERM

\* USE ONLY WITH BRAKE OPTION

**Motor Connector 270-00257 (AEGA052NN00000013000)**

Pin	Function
1	GND(OV)
2	CH A(A)
3	CH A(A\)
4	CH B(B)
5	CH B(B\)
6	CH Z(Z)
7	CH Z(Z\)
8	+5V(+5V)
9	-
10	CH U(RLGU)
11	CH V(RLGV)
12	CH W(RLGW)

**Option 3-Consult Factory**

Custom Designed Servo Motors For Your Specific Application. Call 1-800-358-9070 Today.