

ACCU ELECTRIC MOTORS INC

USA: (888) 932-9183

CANADA: (905) 829-2505

- ✓ Over 100 years cumulative experience
- ✓ 24 hour rush turnaround / technical support service
- ✓ Established in 1993



The leading independent repairer of servo motors and drives in North America.

Visit us on the web:

www.servo-repair.com

www.servorepair.ca

www.ferrocontrol.com

www.sandvikrepair.com

www.accuelectric.com

Scroll down to view your document!

For 24/7 repair services :

USA: 1 (888) 932 - 9183

Canada: 1 (905) 829 -2505

Emergency After hours: 1 (416) 624 0386

Servicing USA and Canada

Gemini GV Hardware Installation Guide

Effective: December 1, 2001

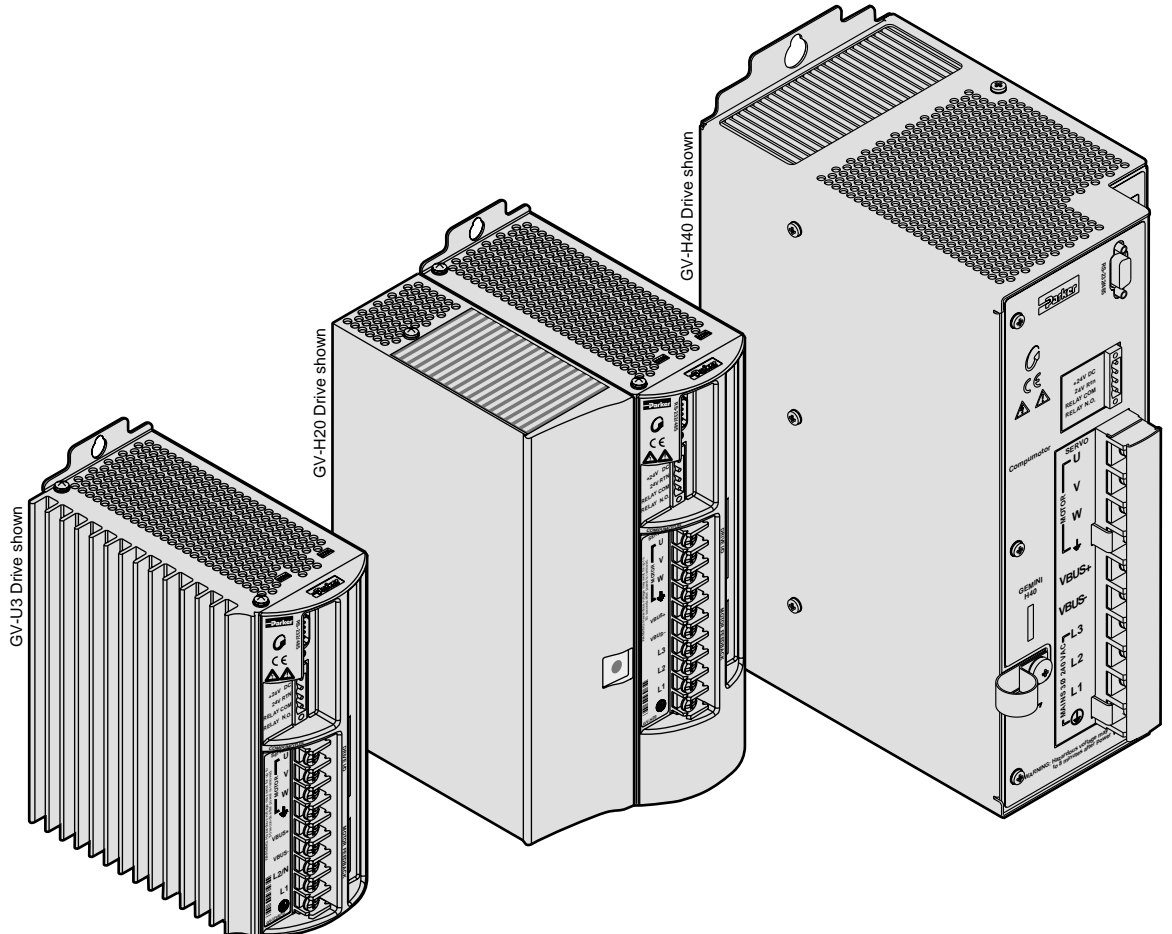

Gemini GV Series
Digital Servo Drives

IMPORTANT

User Information



WARNING



Gemini Series products are used to control electrical and mechanical components of motion control systems. You should test your motion system for safety under all potential conditions. Failure to do so can result in damage to equipment and/or serious injury to personnel.

Gemini Series products and the information in this user guide are the proprietary property of Parker Hannifin Corporation or its licensors, and may not be copied, disclosed, or used for any purpose not expressly authorized by the owner thereof.

Since Parker Hannifin constantly strives to improve all of its products, we reserve the right to change this user guide and software and hardware mentioned therein at any time without notice.

In no event will the provider of the equipment be liable for any incidental, consequential, or special damages of any kind or nature whatsoever, including but not limited to lost profits arising from or in any way connected with the use of the equipment or this user guide.

© 2001 Parker Hannifin Corporation
All Rights Reserved

Motion Planner and Pocket Motion Planner are trademarks of Parker Hannifin Corporation.
Microsoft and MS-DOS are registered trademarks, and Windows, Visual Basic, and Visual C++ are trademarks of Microsoft Corporation.

Technical Assistance ⇨ *Contact your local automation technology center (ATC) or distributor, or ...*

North America and Asia:

Compumotor Division of Parker Hannifin
5500 Business Park Drive
Rohnert Park, CA 94928
Telephone: (800) 358-9070 or (707) 584-7558
Fax: (707) 584-3793
FaxBack: (800) 936-6939 or (707) 586-8586
e-mail: tech_help@cmotor.com
Internet: <http://www.compumotor.com>

Europe (non-German speaking):

Parker Digiplan
21 Balena Close
Poole, Dorset
England BH17 7DX
Telephone: +44 (0)1202 69 9000
Fax: +44 (0)1202 69 5750

Germany, Austria, Switzerland:

HAUSER Elektronik GmbH
Postfach: 77607-1720
Robert-Bosch-Str. 22
D-77656 Offenburg
Telephone: +49 (0)781 509-0
Fax: +49 (0)781 509-176



Technical Support Email
tech_help@cmotor.com

Table of Contents

CHANGE SUMMARY	5
CHAPTER 1 – INTRODUCTION	7
Gemini Products—Overview	8
Compatible Compumotor Products	10
CHAPTER 2 – INSTALLATION	11
Checking Your Shipment	12
“Express Setup” Overview	12
Step 1 – Connecting the Motor	14
Step 2 – Connecting AC Power	16
Step 3 – Configuring the Drive	18
Step 4 – Connecting the 6K Controller	20
What’s Next?	22
CHAPTER 3 – CONFIGURATION	23
Configuration	24
Tuning Procedures	28
Torque Mode Tuning	28
Velocity Mode Tuning	30
Position Mode Tuning	31
Filter Adjustments	33
CHAPTER 4 – SPECIAL FEATURES	35
Relay Connections (optional)	36
+24VDC “Keep Alive” Power Connections (optional)	36
Multiple Drive Installations (optional)	37
Regeneration Protection	38
Aligning the Resolver (optional)	42
RS-232/485 Communications	44
Establishing Communications	44
Configuring the Serial Port	44
RS-232 Communications	45
RS-232 Daisy-Chaining	45
RS-485 Communications	47
RS-485 Multi-Drop	47
Updating the Drive’s Operating System	48
CHAPTER 5 – TROUBLESHOOTING	49
APPENDIX A – SPECIFICATIONS	57
Power Specifications	58
Interface/Communication	59
Inputs and Outputs	60
Feedback Devices	66
Dimensions	69
Protective Circuits	74
Cable Specifications	76
APPENDIX B – USING NON-COMPUMOTOR MOTORS	81
APPENDIX C – REGULATORY COMPLIANCE: UL AND CE	85
INDEX	93

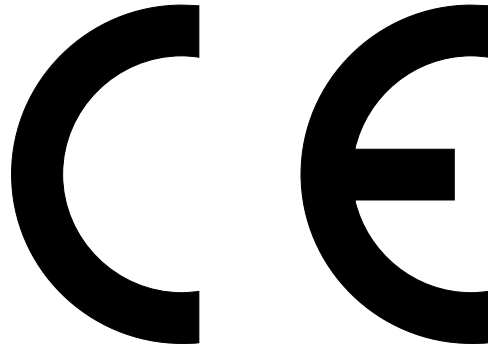

Product Type : Gemini Family of Drives, GV-nnnn

Including, but not limited to :

GV-L3n, GV-U3n, GV-U6n, GV-U12n, GV-H20n, GV-H40n ,
GPDM

When installed in accordance with this installation guide, the above products have been demonstrated to be in compliance with the requirements of directives

- 89/336/EEC Electromagnetic Compatibility Directive
as amended by Directive 92/31/EEC

These products are intended for use in Commercial, Light Industrial and Industrial Environments as defined in the relevant EMC standards.

These products are compliant with the Low Voltage Directive.

- 73/23/EEC Low Voltage Directive
- 93/68/EEC CE Marking Directive

Symbols:



Protective Earth Connection



Earth (Ground) Terminal



Shield, Frame, or Chassis Terminal



Caution, Risk of Electrical Shock



Caution, Refer to Accompanying Documentation

Change Summary

Gemini GV Hardware Installation Guide

Revision E

December 1, 2001

The following is a summary of the primary technical changes to this document since the previous version was released.

This document, part number 88-017791-01E, supersedes 88-017791-01D.

GV-H40 Drive Added to Gemini Product Line

Information about the Gemini GV-H40 Drive has been added throughout this *Hardware Installation Guide*.

+24VDC Power Input – Current Specification (page 37)

The input current specification has been changed from 500 mA *maximum* to 500 mA *minimum* required from your power supply.

Connecting V Bus±: Fuse Each Drive (page 38)

CLARIFICATION: When connecting two or more drives through their V Bus± terminals, fuse the AC input lines of each drive, as the drawing labeled *Sharing the Power Bus* now shows.

TASX, Bit 5 – Resolver Failure (page 52)

CHANGE: The TASX command's Bit 5 indicates resolver failure (not encoder failure).

Soldercup Connectors Specified (page 60 & 66)

NEW: Mating soldercup connectors and backshells are specified for the 50 pin DRIVE I/O connector and the 26 pin MOTOR FEEDBACK connector.

Pulse Input Specifications (page 61)

CLARIFICATION: Specifications are listed for minimum pulse width and maximum pulse frequency for step/direction or encoder inputs.

Panel Layout – Vertical Clearance for GV-H20 (page 73)

CHANGE: Allow 2 inches (50.8 mm) below a GV-H20 drive. If you mount another drive above a GV-H20, allow at least 4 inches (100 mm) vertical clearance above the GV-H20; allow 6 inches (150 mm) if operating at full power.

Non-CE Cables (pages 75 – 80)

NEW: Compumotor now offers non-CE cables.

Hall Sensors – Configuration and Troubleshooting (page 82)

NEW: Information about configuring and troubleshooting Hall sensors has been

added to *Appendix B Using Non-CompuMotor Motors*.

Ferrite Absorbers Recommended for GV-H20 (page 88)

CHANGE: For increased product immunity and reduced product emissions, particularly with large servo motors, we now recommend that you install two clip-on ferrite absorbers.

Revision D

December 17, 1999

The following is a summary of the primary technical changes to this document when part number 88-017791-01D superseded 88-017791-01C.

- DRFLVL Command Removed from Configuration Steps.
- RFS Command Recommended in Reconfiguration.
- Depth Commands Added to Filter Adjustments.

Revision C

November 1, 1999

The following is a summary of the primary technical changes to this document when part number 88-017791-01C superseded 88-017791-01B.

- Information for the Gemini GV-H20n Servo Drive, was added.
- Information for the Gemini Power Dissipation Module (GPDM) was added.
- Information about using resolver feedback was added.
- GC-26, GC-50, GFB-KIT were added.
- Special Features Chapter was added.

Revision B

July 30, 1999

The following is a summary of the primary technical changes that occurred in this document when part number 88-017791-01B superseded 88-017791-01A.

- Z-Channel was added to Encoder Outputs
- We recommended connecting RS-485 cables before applying power.
- Digital Outputs Drawing – minor corrections were made to the *Internal Connections* section of the *Digital Outputs* drawing.

CHAPTER ONE

Introduction

IN THIS CHAPTER

- Gemini Product Overview
 - Compatible Compumotor Products
-

Gemini Products—Overview

The Gemini Series is a *family* of high performance digital drives. The family contains drives for both stepper and servo motors. With many models and options available, the user can choose the precise level of power and control for the application's motion requirements.

Gemini Product Descriptions

Gemini GT and GV

Gemini GT Stepper Drives and GV Servo Drives are the basic Gemini products. They are controlled with standard command interfaces of step/direction (GT and GV) or $\pm 10V$ (GV only), and can be used with standard indexers or controllers.

The drives are configured over RS232/485 with either Motion Planner on a personal computer (PC), or Pocket Motion Planner on a palm PC. Many advanced features are standard in the drives, such as sensorless stall detect and ABS damping in the GT, and digital tuning and notch filters in the GV.

Gemini GT6 and GV6

The Gemini GT6 and GV6 are controller/drives available with several different programming modes. These drives have basic motion control and sequencing capabilities, and can be used in distributed control applications. By using optional plug-in cards, they can be equipped with interfaces for Profibus or DeviceNet.

The GT6 and GV6 are configured and programmed over RS232/485, either with Motion Planner on a PC, or Pocket Motion Planner on a palm PC.

Gemini GT6K and GV6K

The GT6K and GV6K are single axis packaged controller/drives in the Gemini family that offer full 6K Series controller functionality and programmability for complex distributed control applications. Key features include: complex program capabilities such as math, variables, and logic control; flexible and expandable serial I/O modules; and Ethernet compatibility for PC bus access. The user programs these devices over an RS232/485 communication port or Ethernet; a second port is available for use with a full-time operator interface.

Gemini Product Names

The following table lists the meanings of letters and numbers in Gemini product names. Notice that “T” is associated with step motor products (“sTep”), and “V” is associated with servo motor products (“serV_o”).

Control Level:

Step Motor Drives and Controller/Drives

GT	Step Motor Drive
GT6	6000-based Step Motor Controller
GT6K	6K-based Step Motor Controller

Servo Motor Drives and Controller/Drives

GV	Servo Motor Drive
GV6	6000-based Servo Controller
GV6K	6K-based Servo Controller

Power Level:

Step Motor Drives and Controller Drives

L5	120VAC, 5A at 170VDC
L8	120VAC, 8A at 170VDC

Servo Motor Drives and Controller/Drives

L3	120VAC, 3A continuous, 7.5A peak at 170VDC
U3	120/240VAC, single phase, 3A continuous, 7.5A peak at 170/340VDC
U6	120/240VAC, single phase, 6A continuous, 15A peak at 170/340VDC
U12	120/240VAC, single phase, 12A continuous, 30A peak at 170/340VDC
H20	208/240VAC, three phase, 20A continuous, 50A peak at 294/340VDC (single phase: 16A continuous, 50A peak at 294/340VDC)
H40	208/240VAC, three phase, 40A continuous, 100A peak at 294/340VDC

Amperage values represent continuous current, peak of the sine wave.

- “L” = “Low” voltage input (120VAC)
- “U” = “Universal” voltage input (120/240VAC)
- “H” = “High” voltage input (208/240VAC)

Options:

Data Bus (-db) Option (for GT6 and GV6 only):

DN	DeviceNet
PB	Profibus

Feedback (-fb) Option (for Servos only):

E	Encoder/Hall
R	Resolver

Ship Kit Options:

NK	No Kit
----	--------

Format:

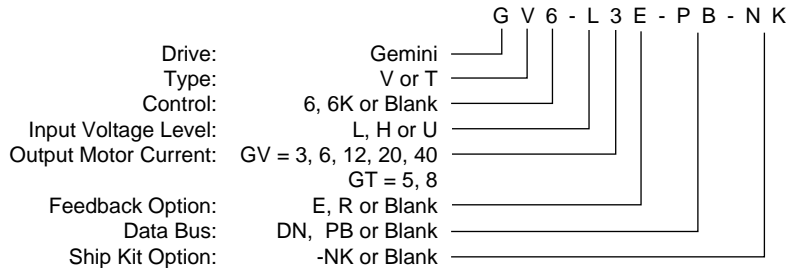

Format Example

Compatible Compumotor Products

GT- <i>nn</i> Stepper	6K or other Compumotor indexer
GV- <i>nnn</i> Servo	$\pm 10V$ mode: 6K or other Compumotor controller Step/Direction mode: 6K or other Compumotor indexer
Software	Motion Planner Pocket Motion Planner (version 1.2 or higher) Note: Gemini drives are not compatible with ASCII communication programs such as Motion Architect or X Language software.
Cables, Motors, etc.:	See list at beginning of <i>Chapter 2 Installation</i> , in <i>Appendix A Specifications</i> , and in the separate <i>Gemini Motor Reference Manual</i> .

User Guides

The following items ship with the drive:

- Gemini Quick Start Guide
- Gemini Hardware Installation Guide
- Gemini Programmer's Reference
- Gemini Motor Reference Manual
- Motion Planner CD-ROM

You can also order the drive only, with none of the above items. Specify the *-NK* option ("No Kit").

Motor Information

Information about Compumotor motors is in the separate *Gemini Motor Reference Manual*.

CHAPTER TWO

Installation

IN THIS CHAPTER

- Checking Your Shipment
 - Express Setup
-

Checking Your Shipment

Inspect your shipment carefully. You should have received one or more of the following:

Gemini Drives

GV-L3n (“n” can be E (for Encoder) or R (for Resolver))
GV-U3n
GV-U6n
GV-U12n
GV-H20n
GV-H40n

Ship Kit Items

The following ship with the drive:

Part	Part Number
Gemini GV Quick Reference Guide	88-017779-01
Gemini GV Hardware Installation Guide	88-017791-01
Gemini Programmer's Reference	88-017778-01
Gemini Motor Reference Manual	88-017790-01
Motion Planner CD-ROM	95-017633-01

Options and Accessories

You may have ordered one or more of the following options or accessories.

Part	Part Number
GPDM Gemini Power Dissipation Module	GPDM
Drive Only (no accompanying manuals)	-NK

Cables: various cables, breakout modules, etc., are available. See *Appendix A Specifications* for cable and accessory information.

Cable clamps, EMC filters, ferrites, etc., are available. See *Appendix C Regulatory Compliance* for part numbers and more information.

Motors

You may have ordered a motor from one of the following families of Compumotor motors:

SM Series	BE Series	J Series
NeoMetric Series	M Series	Linear Series

“Express Setup” Overview

This chapter gives instructions for performing an *express setup*. The purpose of the express setup is to verify that the drive, cables, and motor work properly as a system. It will also verify serial communications and controller connections.

You will connect together only the components necessary to achieve basic motion—a drive, a motor (without a load connected), and a controller. You will use a computer to communicate with the drive, and with the controller.

In the express setup, we will give procedures for the following steps:

1. Connecting the motor to the drive (with no load attached)
2. Connecting AC power to the drive
3. Establishing communications and configuring the drive for autorun
4. Connecting a controller, enabling the drive, and observing the motor turn

Information you may need for final installation will be presented in *Chapter 3 Configuration*, in *Chapter 4 Special Features*, in *Appendix A Specifications*, and in the separate *Gemini Motor Reference Manual*.

The next drawing shows locations and names of the Gemini components that you will encounter during the installation procedure.

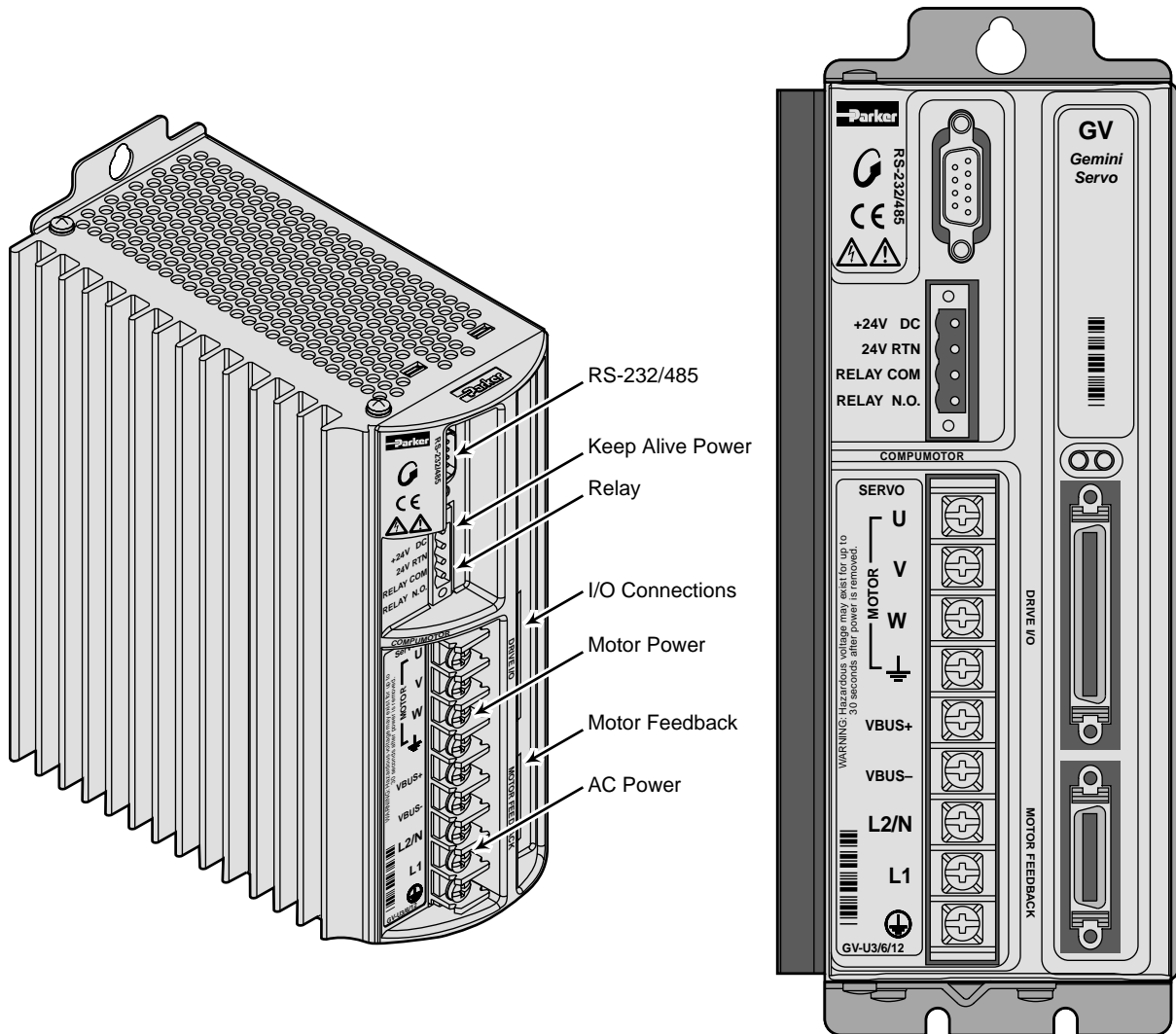

Component Locations

Illustrations in this Installation Guide

We will usually show the Gemini GV-U3n Drive in illustrations. Other Gemini drives have similar features. In cases where we need to illustrate *differences* between drives, we will show relevant drawings for each drive.

System Overview

In this express setup procedure, we will give instructions for a Compumotor system—Gemini drive with Compumotor motor, Compumotor cables, and Compumotor 6K controller.

If you use non-Compumotor equipment, try to follow along and perform the steps in the Express Setup procedure; consult *Appendix A Specifications* for additional information you may need.

The next drawing shows the components of a Compumotor system.

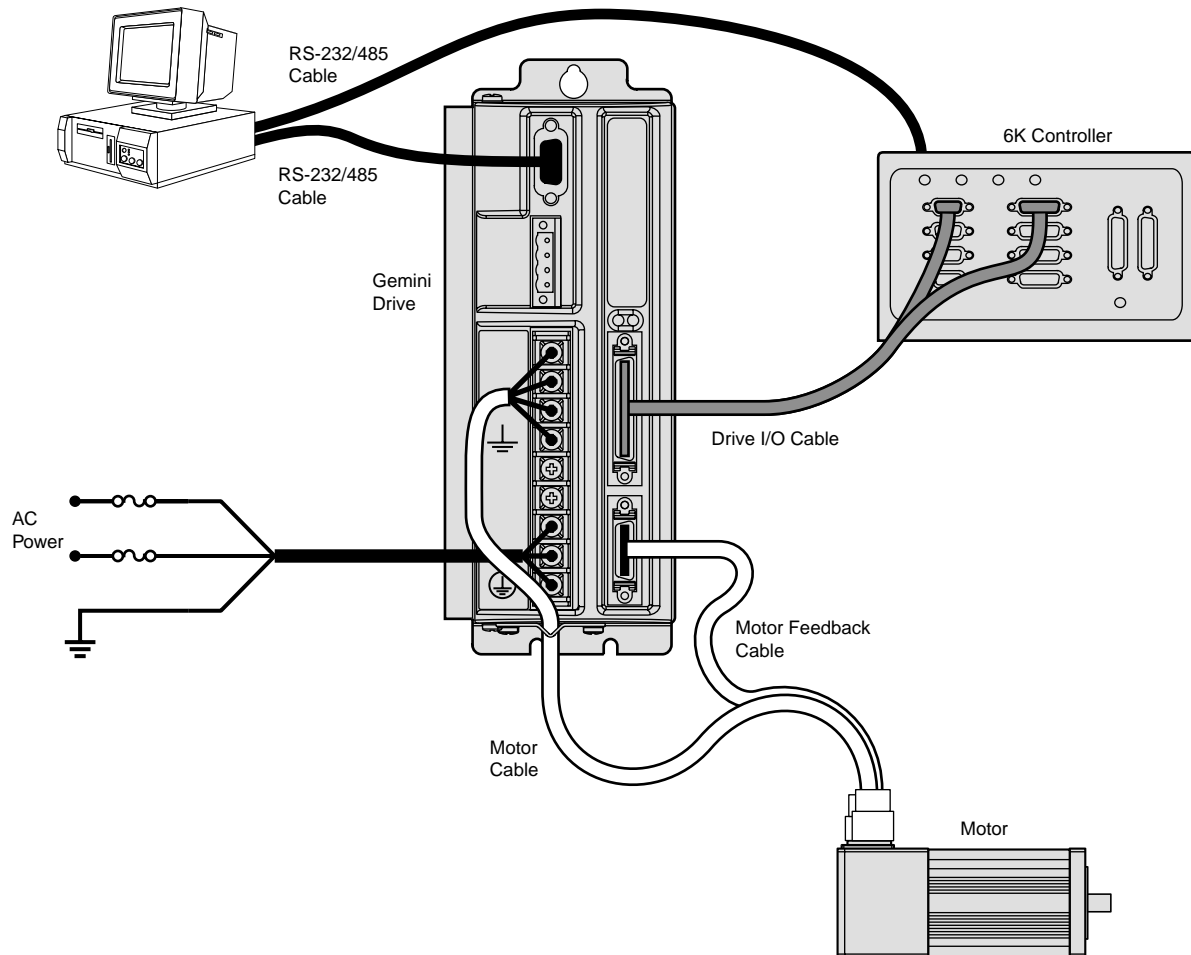

Compumotor System

If you use a Compumotor controller other than the 6K, see *Appendix A Specifications* for wiring instructions.

Step 1 – Connecting the Motor

Compumotor's motor cable with the GS or GB option has an MS connector on one end. The other end has three black wires with identifying white numbers (1, 2, or 3), and one green/yellow wire. (See the separate *Gemini Motor Reference Manual* for motor specifications, dimensions, speed/torque curves, and wiring diagrams for your particular motor.)

Connecting the Motor Cable

1. Connect the MS connector on the motor cable to the mating connector on the motor. (If you use a non-Compumotor motor, see *Appendix B* for information.)
2. Remove the clear plastic cover from the drive terminals. Connect the motor cable's green/yellow wire to the drive terminal with the \perp symbol. This connects the motor's protective conductor terminal to the drive's safety earth.
3. Connect your motor cable's phase wires 1, 2, and 3 to the drive's U, V, W terminals, respectively, as shown in the drawing below.



WARNING



The drive's barrier strip terminals are at hazardous voltages when power is applied to the drive, and up to 30 seconds after power is removed. Lower voltages may still be present for several minutes after power is removed. Reinstall the clear plastic terminal cover after you make connections.

4. Secure the cable to the drive by placing the exposed cable shield in the saddle clamp on the bottom of the drive (GV-H20n/H40n: R-Clamp on heatsink). Make the loop of cable between saddle clamp and drive terminals as short as possible.

Connecting the Motor Feedback Cable

Compumotor's motor feedback cable with the GS or GB option has an MS connector on one end, and a 26 pin connector on the other end.

1. Connect the MS connector on the motor cable to the mating connector on the motor.
2. Connect the 26 pin connector on the motor cable to the drive's MOTOR FEEDBACK connector.
3. Tighten the jack screws on the connector housing to secure the connector to the drive.

Secure the Motor

1. If your motor is not permanently mounted, clamp it securely in place during this Express Setup procedure.

The next drawing illustrates these connections.

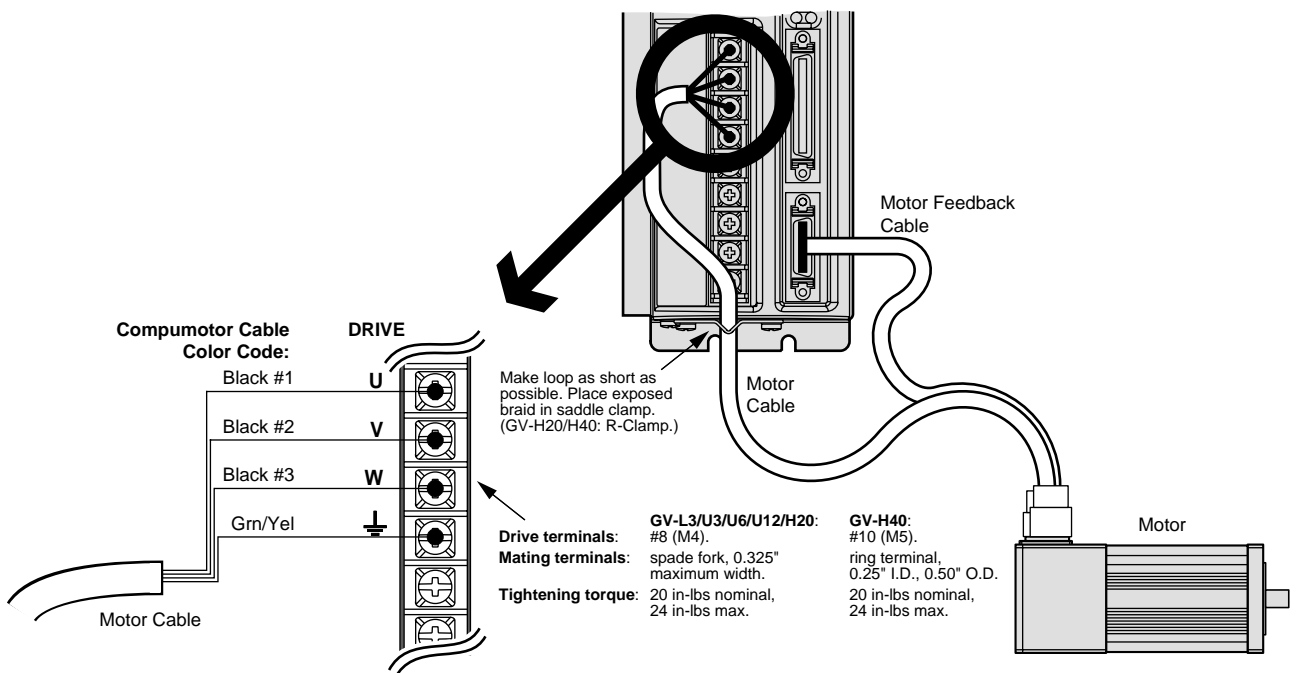

Motor Wiring – Typical

Step 2 – Connecting AC Power

Acceptable ranges of AC input voltage are listed below for each drive :

Drive	AC Input Range
GV-L3n	95 – 132VAC
GV-U3n/U6n/U12n	95 – 264VAC
GV-H20n	165 – 264VAC [single phase (1Ø) or three phase power (3Ø)]
GV-H40n	165 – 264VAC [three phase power (3Ø) only]



WARNING



You must connect the drive's protective conductor terminal, marked with the \oplus symbol, to a reliable system safety earth. Make the connection directly, by means of a low impedance path less than or equal to 0.1 ohm (no fuses, etc.). Under normal operation, no current should flow through the safety earth connection.



WARNING



The drive's barrier strip terminals are at hazardous voltages when power is applied to the drive, and up to 30 seconds after power is removed. Lower voltages may still be present for several minutes after power is removed. Reinstall the clear plastic terminal cover after you make connections.

Fuse Information

Gemini drives have no internal fuses. For safety, you must provide a fuse in each of the AC input lines. Recommended fuse types and sizes are:

Drive Type	Fuse Style	Rating	Fuse Type
GV-L3n (120VAC)	125VAC Time Delay	10 amp	Type RK5 or better
GV-U3n/6n/12n (120VAC)	125VAC Time Delay	30 amp	Type RK5 or better
GV-U3n/6n/12n (240VAC)	250VAC Time Delay	30 amp	Type RK5 or better
GV-H20n (208/240VAC, 1Ø/3Ø)	250VAC Time Delay	30 amp	Type RK5 or better
GV-H40n (208/240VAC, 3Ø)	250VAC Time Delay	60 amp	Type RK5 or better

The next table lists part numbers for suitable fuses, from several manufacturers:

Amps	Bussmann	Goold	Littelfuse	Grainger
10	FRN-R-10	TR10R	FLNR10	1A693
30	FRN-R-30	TR30R	FLNR30	1A698
60	FRN-R-60	TR60R	FLNR060	1A700

Connecting Power

GV-L3n: Connecting AC Power



CAUTION



Do not operate the GV-L3n above 132VAC, or the drive will be permanently damaged.

120VAC Operations:

1. Connect power system's safety earth to drive's protective conductor terminal, marked with the \oplus symbol. Do not fuse the protective conductor terminal.
2. Connect 120VAC, 50/60 Hz, single phase power line to drive's L1 terminal.
3. Connect neutral to drive's N terminal.
4. **Reinstall the clear plastic terminal cover after you make connections.**

Connections are illustrated in the next drawing.

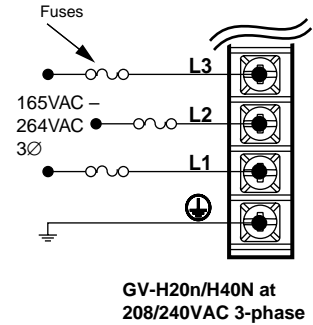
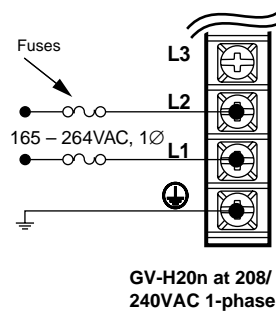
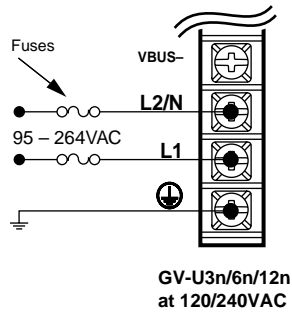
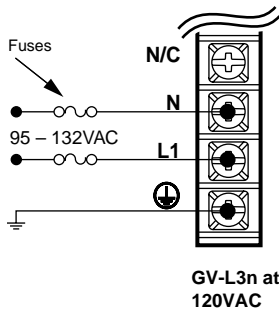

Drive terminals:	GV-L3/U3/U6/U12/H20: #8 (M4).	GV-H40: #10 (M5).
Mating terminals:	spade fork, 0.325" maximum width.	ring terminal, 0.25" I.D., 0.50" O.D.
Tightening torque:	20 in-lbs nominal, 24 in-lbs max.	20 in-lbs nominal, 24 in-lbs max.

Power Connections

GV-U3n/6n/12n: Connecting AC Power

Connections are illustrated in the drawing above.

208/240VAC Operations:

1. Connect power system's safety earth to drive's protective conductor terminal, marked with the \oplus symbol. Do not fuse the protective conductor terminal.
2. Connect 208/240VAC, 50/60 Hz, single phase power to drive's L1 and L2/N terminals.
3. **Reinstall the clear plastic terminal cover after you make connections.**

120VAC Operations:

1. Connect power system's safety earth to drive's protective conductor terminal, marked with the \oplus symbol. Do not fuse the protective conductor terminal.
2. Connect 120VAC, 50/60 Hz, single phase power line to drive's L1 terminal.
3. Connect neutral to drive's L2/N terminal.
4. **Reinstall the clear plastic terminal cover after you make connections.**

GV-H20n: Connecting Single Phase AC Power

Connections are illustrated in the drawing above.

Single Phase 208/240VAC Operations:

1. Connect power system's safety earth to drive's protective conductor terminal, marked with the \oplus symbol. Do not fuse the protective conductor terminal.
2. Connect 208/240VAC, 1Ø, 50/60 Hz power to drive's L1 and L2 terminals.
3. **Reinstall the clear plastic terminal cover after you make connections.**

NOTE: Default current settings are for three phase operation. For single phase, you must modify the current settings in *Step 3 – Configuring the Drive* on the next page.

GV-H20n/H40n: Connecting Three Phase AC Power

Connections are illustrated in the drawing above.

Three Phase 208/240VAC Operations:

1. Connect power system's safety earth to drive's protective conductor terminal, marked with the \oplus symbol. Do not fuse the protective conductor terminal.
2. Connect 208/240VAC, 3Ø, 50/60 Hz power to drive's L1, L2 and L3 terminals.
3. **Reinstall the clear plastic terminal cover after you make connections.**

Applying Power

1. Verify that the load is not connected to the motor, and that the motor is clamped securely in place.
2. Verify that a cable is not attached to the DRIVE I/O connector.
3. Apply power to the drive. After the power-up sequence, the LEDs should display the following state:

Left LED	Right LED	Indicated State
red	off	Drive ready, not enabled

Proceed to *Step 3 – Configuring the Drive*.

Step 3 – Configuring the Drive

Gemini drives have no DIP switches or potentiometers for configuration. You will use software tools to communicate with the drive and configure drive settings.

Configuration Software

Two software programs are located on the Motion Planner CD-ROM. *Motion Planner* runs on a personal computer (PC). *Pocket Motion Planner* runs on a palm PC or Handheld Personal Computer (HPC) that uses Windows CE 2.0 or higher, or on a PC. These programs are also available on the Compumotor web site at <http://www.compumotor.com>.

Information about installing and using each of these software tools can be found in the *Gemini Programmer's Reference*.

Establishing Communications

We assume you are using a Gemini drive and a 6K controller, and that you have only one serial port on your PC. The following procedures give instructions for moving the cable back and forth between the Gemini and 6K.



WARNING



This procedure causes the motor shaft to move. Do not connect a load to the shaft.

1. Verify that a load is not connected to the motor, and that the motor is clamped securely in place.
2. Verify that a cable is not attached to the DRIVE I/O connector.
3. Using a null modem cable, connect the drive's RS-232/485 connector to the serial port on your PC, palm PC, or HPC. (A null modem cable is available from Compumotor. See *Appendix A Specifications* for more information.) It is not necessary to turn off AC power before you plug in an RS-232 cable; however, connect RS-485 cables *before* applying AC power.
4. Install and launch Motion Planner or Pocket Motion Planner.

Proceed to *Configuring the Drive*.

Configuring the Drive

Choose one of the columns below, based upon which software program you are using—Motion Planner, or Pocket Motion Planner—and follow the procedure to configure your drive.

NOTE: If this is not the first time the drive has been configured, issue an RFS command (Return to Factory Settings) from the terminal emulator, before performing the following procedures.

Configuring the Gemini Drive with Motion Planner

1. Install and launch Motion Planner
2. When the product selection dialog appears, select a Gemini drive and select the COM port to which the Gemini is connected.
3. In the Editor window, click on the Gemini button at the top of the window to launch the setup wizard.
3. To verify communications with the drive, click the "Terminal" tab on the bottom of the screen to enter terminal mode. Issue the following command:
TREV (transfers the drive's revision level)
Revision level information for your drive should appear on the screen.
To solve communication problems: see *RS-232/485 Communications* in *Chapter 4 – Special Features*.
4. Select "Express Setup", and select "Initialize wizard with factory defaults". (If you wish to keep the existing drive configuration, you should upload it and then initialize from the editor.)
5. Click the "Next" button to proceed with the wizard. Fill in the wizard dialogs as prompted, including choosing a motor series, frame size, and part number. At the end of the wizard, click the "finish" button; this creates the setup code and places it in the Editor window. (For GV-H20 using single phase power, see *Note 2* below.)
6. Select File/Save to save the setup code to a file (*.prg) on your hard drive.
7. Select Communications/Download to download the setup code (contents of the Editor window) to the Gemini drive. When the download is complete, choose to "Reset" the drive.
Drive setup is complete. All of the setup parameters (command values) are stored in the Gemini drive's EEPROM and are automatically recalled when you cycle power or reset the drive.
8. Click the "Terminal" tab on the bottom of the screen to enter terminal mode.
9. Issue a DMODE13 command. This configures the drive for autorun mode, in which the motor runs open loop in the clockwise direction at 1 rps. (The motor will not begin turning, though, because you have not yet enabled the drive.)

Proceed to *Step 4 – Connecting the 6K Controller*.¹

Configuring the Gemini Drive with Pocket Motion Planner

1. Install and launch Pocket Motion Planner.
2. Select "Tools/Config Tool".
3. Select "Edit Current Configuration" for factory defaults. (Or upload the existing configuration, and then select "Edit Current Configuration".)
4. Select drive type by choosing "Auto Detect". The software will identify the drive type, and automatically use settings for your specific drive type. If the message "Auto Detect Failed" appears, see *RS-232 Communication Problems* in *Chapter 4 Troubleshooting*.
5. Select "Express Setup"
6. Choose a motor series, frame size, and part number. (For GV-H20 using single phase power, see *Note 2* below.)
7. Save your configuration file
8. Download the configuration file to the Gemini drive; choose to "Reset" the drive.
9. Enter terminal mode.
10. Issue a DMODE13 command. This configures the drive for autorun mode, in which the motor runs open loop in the clockwise direction at 1 rps. (The motor will not begin turning, though, because you have not yet enabled the drive.)

Proceed to *Step 4 – Connecting the 6K Controller*.¹

¹ If you are not using a 6K controller, proceed to *Verifying Correct System Operations without a 6K Controller*, in *Step 4* on the following pages.

² GV-H20 default current values are for three phase operation. If you use single phase power with the GV-H20, you must manually modify the current values as follows:

- Set continuous current (DMTIC) to 11.3 amps rms or less
- Set peak current (DMTIP) to 28.3 amps rms or less

Depending upon which motor you selected, your settings may already be lower than these limits.

Step 4 – Connecting the 6K Controller

Connecting the 6K Controller and Enabling the Drive

In this section of Express Setup, you will use the 6K to enable the Gemini drive. When you issue the DRIVE1 command in Step 5, the 6K will connect the Gemini's enable input to ground, thus enabling the drive.

NOTE: If you are not using a 6K controller, proceed to *Verifying Correct System Operations Without a 6K Controller*, on the next page.

We assume below that you will connect the Gemini drive to Axis 1 on the 6K. If you use a different axis, modify the commands below accordingly.

NOTE: Pocket Motion Planner can *not* be used to communicate with the 6K. Only use Motion Planner to communicate with the 6K.

1. In Motion Planner, end the session with the Gemini drive by exiting the program. Save changes. (Exiting the program stops *binary* communications with the drive.)
2. Move the null modem cable from the drive's RS-232/485 connector to the 6K's COM port.
3. Restart Motion Planner and establish communications with the 6K:
 - Select File/New/Terminal Emulator/OK.
 - Under Communications/Settings, select the 6K product and COM port you are using. (When you select a 6K product, Motion Planner begins *ASCII* communications with that 6K product.)
4. From Motion Planner, issue the following commands to the 6K:
 - DRIVE0 (ensures the drive is disabled)
 - CMDDIR0 (ensures clockwise is the positive direction)
 - SMPER0 (disables position error fault)
5. Configure the 6K axis by sending one of the following commands:
 - AXSDEF1 (configures axis 1 for analog servo control)
 - AXSDEF0 (configures axis 1 for step and direction)
6. Connect the 6K's Axis 1 to the Gemini's DRIVE I/O connector. Use the appropriate cable for your mode of operation.
 - Torque or Velocity Mode: use the Analog Command Cable
 - Position Mode: use the Step & Direction Command Cable

Tighten the thumbscrews on the cable. It is not necessary to turn off AC power before you plug in the cable. (Because you issued a DRIVE0 command above, the drive should not enable when you connect the cable.)
7. From Motion Planner, issue the following command to the 6K
 - DRIVE1 (enables the drive)

The motor should begin turning.

Proceed to *Verifying Correct System Operations*.

Verifying Correct System Operations

Choose one of the columns below, based upon which controller you are using—6K or non-6K—and follow the procedure to verify correct system operations.

Verifying Correct System Operations with a 6K Controller

1. Verify that the drive is enabled. (Left LED is illuminated green; right LED flashes yellow/green during autorun.)
2. Verify that the motor is rotating clockwise at approximately one revolution per second, as viewed from the shaft end of the motor. (The motor is turning because earlier you configured the drive for autorun.)
3. (NOTE: If you operate the drive in position mode, skip Steps 3 and 4.)
From Motion Planner, issue a TPE command to the 6K and note the response.
4. Repeat the TPE command. The response should be more positive than the previous response. This indicates that the encoder is turning in the correct direction.
If your system does not perform properly, find and correct the problem before proceeding. If necessary, see *Chapter 4 Troubleshooting*.
5. From Motion Planner, issue the following commands:
 - DRIVE0 (disables the drive)
 - Reconfigure the SMPER setting to its previous value, if necessary. (Factory default value is 4000.)
 - For the 6K to read and react to a GV fault, enter the command DRFEN1 for each axis.
6. End the Motion Planner session with the 6K by closing the terminal and the editor.

Proceed to *Reconfiguring the Drive*, below.

Reconfiguring the Drive

1. Connect the null modem cable from the PC to the drive's RS-232/485 connector.
2. In Motion Planner, establish communications with the Gemini drive:
 - Select File/New/Terminal Emulator/OK.
 - Under Communications/Settings, select the GV.
3. Configure the Gemini drive for the intended mode of operation:
 - Issue a DMODE2 command to configure the drive for torque mode.
 - Or, issue a DMODE6 command to configure the drive for step/direction mode.

This completes the *Express Setup* procedure.

Verifying Correct System Operations without a 6K Controller

1. Enable the drive by connecting a jumper between pin 1 and pin 2 on the 50 pin DRIVE I/O connector. (For connector diagrams, see *Appendix A Specifications*.)
2. Verify that the drive is enabled. (Left LED is illuminated green; right LED flashes yellow/green during autorun.)
3. Verify that the motor is rotating clockwise at approximately one revolution per second, as viewed from the shaft end of the motor. (The motor is turning because earlier you configured the drive for autorun.)
4. (NOTE: If you operate the drive in position mode, skip Steps 3 and 4.)
From the Motion Planner terminal, issue a TPE command to the Gemini and note the response.
5. Repeat the TPE command. The response should be more positive than the previous response. This indicates that the encoder is turning in the correct direction.
If your system does not perform properly, find and correct the problem before proceeding. If necessary, see *Chapter 4 Troubleshooting*.

Proceed to *Step 3 of Reconfiguring the Drive*, below.

What's Next?

This chapter has given you information and instructions for performing an *Express Setup*. The following list explains the steps you should take to complete your installation, and indicates where to find additional information for each of those steps.

1. **Mount the drive.** For information on drive dimensions, environmental specifications, airflow and cooling, etc., see *Appendix A Specifications*.
2. **Mount the motor.** For information on motor dimensions, motor cables, encoders, speed/torque curves, etc., see the separate *Gemini Motor Reference Manual*.
3. **Make System Connections.** Information about Compumotor cables is in *Appendix A Specifications*. For information on cabling practices to reduce electrical noise, see *Appendix C Regulatory Compliance: UL and CE*.

Connect any of the drive's optional features you may wish to use (see *Appendix A Specifications* for more information):

- Reset Input
- VINref – Voltage Input Reference
- Digital Inputs (and CNTRL-P)
- Digital Outputs
- Encoder Output
- Analog Monitor

Connect any of the drive's special features you may wish to use (see *Chapter 4 Special Features* for more information):

- Relay, and how to control a Motor Brake
- +24VDC "Keep Alive" Power
- Multiple Drive Installations
- Connecting drive power buses together
- Regeneration and the GPDM Power Dissipation Module
- Aligning the Resolver
- RS-232 Daisy Chain
- RS-485 Multi-Drop

4. **Connect the Load.**
5. **Configure Your Drive.** After completing your hardware installation in Steps 1 – 4 above, proceed to *Chapter 3 Configuration* for information about additional drive configuration options.
6. **Tune Your System.** Tune your system according to the drive mode you use:
 - **Torque Mode** – When you selected a Compumotor motor during *Express Setup*, default tuning gains were downloaded into the drive's memory for that motor. In most cases, no further *drive* tuning is necessary. Consult your controller's user guide for *controller* tuning instructions.

If you need higher performance than you can achieve through controller tuning, you can perform the *Torque Mode Tuning* procedure, found at the end of *Chapter 3 Configuration*.

- **Velocity Mode** – Perform the *Velocity Mode Tuning* procedure, found at the end of *Chapter 3 Configuration*.
- **Position Mode** – Perform the *Position Mode Tuning* procedure, found at the end of *Chapter 3 Configuration*.

CHAPTER THREE

Configuration

IN THIS CHAPTER

- Configuration
 - Tuning Procedures
-

Configuration

You can configure the Gemini drive's settings for optimum system performance. For most of these settings, configuration is optional—if you do nothing, the drive will use default values the very first time it powers up. If you change any settings, the new settings are saved automatically. Most changed settings are effective immediately, but some require that you issue a reset (software RESET command, reset input, or cycle power) before the drive acts upon them.

This chapter will give an overview of all software commands that configure drive settings. For more in depth descriptions about the software commands, see the separate *Gemini Programmer's Reference*.

At the end of this chapter, we have provided tuning procedures you can use to configure the Gemini drive's tuning settings.

Software Programs for Configuration

Two software programs are located on the Motion Planner CD-ROM. *Motion Planner* runs on a personal computer (PC). *Pocket Motion Planner* runs on a palm PC or Handheld Personal Computer (HPC) that uses Windows CE 2.0 or higher, or on a PC. These programs are also available on the Compumotor web site at <http://www.compumotor.com>.

Information about installing and using each of these software tools can be found in the *Gemini Programmer's Reference*.

Overview of Configuration Commands

Motion Planner and Pocket Motion Planner's configuration procedures present commands in groups organized by function. The overview below is organized similarly to the software's *Full Configuration* procedure. (*Express Setup*, which was discussed in *Chapter 2 Installation*, gives you fewer configuration options.)

Motor Settings

If you select a Compumotor motor from the list of motors the software presents to you, the software will send settings to the drive for the motor you selected. No further motor setting configuration is necessary on your part.

If you use a non-Compumotor motor, or choose to manually configure a Compumotor motor, use the following commands to configure motor settings. Also see *Appendix B – Using Non-Compumotor Motors* for additional instructions.

Command	Description
ERES	feedback resolution (encoder or resolver)
DMTIC	continuous current
DMTICD	continuous current derating
DMTKE	motor constant
DMTRES	line-to-line resistance
DMTJ	rotor inertia
DPOLE	number of pole pairs
DMTW	rated speed
DMTIP	peak current

DMTLMN	minimum line-to-line inductance
DMTLMX	maximum line-to-line inductance
DMTD	motor damping
DMTRWC	motor thermal resistance (winding to case)
DMTTCM	motor case (and heatsink) thermal time constant
DMTTCW	motor winding thermal time constant
DPWM	PWM switching frequency
DMTMAX	motor maximum temperature
SHALL	Hall sensor orientation

System Settings

The system settings configure the drive's mode of operation, resolution, direction, and fault modes.

Drive Settings

Command	Description	Options:
DMODE	mode of operation:	no mode defined torque control ($\pm 10V$) velocity control ($\pm 10V$) position control (step/direction) position control (step/direction inverted— inverts sense of direction signal) position control (clockwise/counterclockwise) encoder tracking ¹ autorun ² torque tuning mode velocity tuning mode position tuning mode
DRES	input step resolution	you enter a number (position mode only)
ORES	pseudo encoder output resolution	you enter a number
DMTLIM	torque limit	you enter a number
DMTSCL	torque scale	you enter a number
DMVLIM	velocity limit	you enter a number
DMVSCL	velocity scale	you enter a number

¹Encoder tracking mode uses incoming quadrature encoder pulses to command motion.

²Autorun mode commands motion with no pulse source connected. It is used during Express Setup, and for troubleshooting.

Load Settings

Command	Description	Options:
LJRAT	load to rotor inertia ratio	you enter a number
LDAMP	load damping	you enter a number

Fault Settings

Command	Description	Options:
FLTSTP	fault on startup indexer pulses	can be turned on or off
FLTDSB	fault on disable	can be turned on or off
SMPER	maximum position error	you enter a number
SMVER	maximum velocity error	you enter a number
DIFOLD	enable current foldback	can be turned on or off
DMTAMB	motor ambient temperature	you enter a number
DHALL	fault on encoder/Hall mismatch	can be turned on or off

Input/Output (I/O) Settings

The I/O settings configure the drive's three digital inputs, three digital outputs, and two analog monitors.

Digital Inputs

Command	Description	Options:
LH	hard limit disable	hard limits disabled negative limit only positive limit only both hard limits enabled
INLVL	input sense	active high or active low
INDEB	input debounce time	can be set in milliseconds

Digital Outputs

Command	Description	Options:
OUTLVL	output sense	active high or active low

Analog Monitors

Command	Description	Options:
DMONAV	analog monitor A variable	unused/turn off variable motor temperature drive temperature position error velocity setpoint actual velocity torque/force setpoint actual (electrical) torque velocity error phase A (or U) commanded current phase A (or U) actual current phase B (or V) commanded current phase B (or V) actual current d-axis commanded current d-axis actual current q-axis commanded current q-axis actual current
DMONAS	analog monitor A scaling ¹	you enter a percentage ¹
DMONBV	analog monitor B variable	same choices as DMONAV
DMONBS	analog monitor B scaling ¹	you enter a percentage ¹

¹Monitor output is scalable from -2000% to +2000%, but is limited to $\pm 10V$ peak to peak.

Communications Settings

The communication settings configure the drive for RS-232/485 communications.

RS-232/485

Command	Description	Options:
ERRLVL	error level	you enter a number
ECHO	echo enable	can be turned on or off
E	listening	can be turned on or off

Tuning Settings

Tuning settings are divided into two groups: primary and advanced. Tuning can be done in torque, velocity, or position mode. Tuning procedures for each of these modes are presented below. Relevant commands are:

Primary Tuning – Torque Mode Commands

Command	Description	Options:
DIBW	current loop bandwidth	you enter a number

Primary Tuning – Velocity Mode Commands

Command	Description	Options:
DVBW	velocity loop bandwidth	you enter a number

Primary Tuning – Position Mode Commands

Command	Description	Options:
DPBW	Position loop bandwidth	you enter a number

Advanced Tuning – All Mode Commands

Command	Description	Options:
DIBW	current loop bandwidth	you enter a number
DVBW	velocity loop bandwidth	you enter a number
DPBW	position loop bandwidth	you enter a number
SGIRAT	current (torque) damping ratio	you enter a number
DNOTAF	notch filter A frequency	you enter a number
DNOTAQ	notch filter A quality factor	you enter a number
DNOTBF	notch filter B frequency	you enter a number
DNOTBQ	notch filter B quality factor	you enter a number
DNOTLD	notch lead filter frequency	you enter a number
DNOTLG	notch lag filter frequency	you enter a number

Advanced Tuning – Velocity Mode Commands

All of the torque mode advanced tuning commands are available, plus:

Command	Description	Options:
SGVRAT	velocity damping ratio	you enter a number
SGINTE	integration ON/OFF	can be turned on or off

Advanced Tuning – Position Mode Commands

All of the torque mode advanced tuning commands are available, plus:

Command	Description	Options:
SGPSIG	position/velocity bandwidth ratio	you enter a number
SGPRAT	position damping ratio	you enter a number
SGINTE	integration ON/OFF	can be turned on or off

Tuning Procedures

During the *Express Setup* procedure in *Chapter 2 Installation*, the drive uses default values for tuning parameters, based upon the motor information you entered. That procedure assumes that the motor is unloaded. In the following tuning procedures, you will enter in system information that will characterize the load on the motor.

If you are operating the Gemini drive in torque mode, it is not necessary for you to enter in motor load information. The default tuning parameters for torque mode are set to provide suitable motor performance. Should you wish to modify the default values and fine tune you system, proceed to the *Torque Mode Tuning* section below.

The default tuning parameters for velocity and position modes are set to provide good, stiff motor shaft performance for a given load setting. With the default tuning parameters set in the *Express Setup* procedure, you need only set the system load-to-rotor inertia ratio and your system will be tuned.

Entering Load Settings

The main load setting you will adjust is LJRAT, which is the load-to-rotor inertia value for your system. The more accurately you know this value, the closer your tuning bandwidth settings will correspond to the actual dynamic performance of your system. If you only know this value approximately, you can adjust this value until you achieve the system performance you desire. The total system inertia is given by the following formula:

$$\text{Total system inertia} = \text{motor rotor inertia} * (1 + \text{LJRAT})$$

If your system has significant mechanical damping, you will also want to adjust the LDAMP setting which specifies system damping provided by the load. If you know that you have significant damping in your system from your load but do not know its exact value, you can adjust this value until you achieve the system performance that you desire.

Both the LJRAT and the LDAMP values can be set in the *Full Configuration* section of Pocket Motion Planner or in the *Full Setup* section of the Gemini wizard in Motion Planner. These values can also be set in the terminal modes of Pocket Motion Planner and Motion Planner. During the tuning process you may want to use the terminal emulator to establish appropriate values for these parameters and then upload and save the drive's full configuration settings for use with other units.

Torque Mode Tuning

For most applications, the default tuning values for your drive/motor combination from the *Express Setup* procedure in *Chapter 2 Installation* will provide good performance. Use the following procedures if you need to adjust these values.



WARNING



This procedure causes the motor shaft to move. Make sure that shaft motion will not damage equipment or injure personnel.

Torque Mode Tuning Procedure

Primary Tuning Procedure

1. Disable the drive.
2. Configure the drive for *torque tuning mode* (DMODE15). In this mode, the drive commands a bipolar step change in current, proportional to the motor's continuous current rating, at a 10 Hz repetition rate. (The drive will ignore torque commands on its command input terminals which may come from an external device, such as a servo controller.)
3. Configure ANALOG MONITOR A to show *commanded* d-axis current (DMONAV16).
4. Configure ANALOG MONITOR B to show *actual* d-axis current (DMONBV17).
5. Connect one channel of your oscilloscope to the drive's ANALOG MONITOR A (pin 21). Connect your oscilloscope's ground to the drive's ANALOG GROUND (pin 25).
6. Connect a second channel of your oscilloscope to the drive's ANALOG MONITOR B (pin 22). Connect your oscilloscope's ground to the drive's ANALOG GROUND (pin 25).

Adjust your oscilloscope to display commanded versus actual d-axis current. (The analog monitors can be scaled, in percent, with the DMONAS and DMONBS commands.)

7. Enable the drive and observe your system's response, using the oscilloscope. (The motor may move back and forth slightly.)

Ringling or an oscillating response indicates that the current loop bandwidth is too high. To eliminate oscillations:

- decrease bandwidth using the DIBW command.

A sluggish response, or actual current that remains below commanded current, indicates that bandwidth is too low. To improve the response:

- increase bandwidth by using the DIBW command. However, increasing bandwidth higher than the default value is usually not helpful.

8. After you achieve a satisfactory system response, reconfigure the drive for torque mode (DMODE2). This completes the primary tuning procedure.

If you are unable to achieve a satisfactory response, proceed to the advanced tuning procedure below.

Advanced Tuning Procedure

1. Configure the drive for torque tuning mode (DMODE15), and connect an oscilloscope, as described in Steps 1 – 6 in the *Primary Tuning Procedure* above.
2. Enable the drive and observe your system's response.

Ringling or an oscillating response indicates that the current loop bandwidth is too high, or the current loop damping is too low. To eliminate oscillations:

- decrease bandwidth using the DIBW command; then, if necessary:
- adjust damping by using the SGIRAT command. Use the value that gives the best performance.

A sluggish response indicates that bandwidth is too low, or damping is too high. To improve the response:

- increase bandwidth by using the DIBW command; then, if necessary:
- adjust damping by using the SGIRAT command. Use the value that gives the best performance.

3. OPTIONAL: Null the Input Offset.

First: command zero volts by using either of two methods:

Method 1: connect your controller or command voltage source, and command zero volts; or:

Method 2: disconnect the controller or command voltage source, and short CMD+ to CMD- (pin 23 to pin 24).

Second: Issue a DCMDZ command to null any offset at the command input.

4. After you achieve a satisfactory system response, reconfigure the drive for torque mode (DMODE2). This completes the advanced tuning procedure.

If ringling or oscillations persist, and do not seem to be affected by bandwidth adjustments, you may need to use notch filters or lead/lag filters. See the *Filter Adjustments* procedure at the end of this *Tuning* section.

Velocity Mode Tuning

For most applications, the default tuning parameters for velocity and position modes are set to provide good, stiff motor shaft performance for a given load setting. With the default tuning parameters set in the *Express Setup* procedure, you need only set the system load-to-rotor inertia ratio and your system will be tuned. If your system has significant mechanical damping, you may need to set the system damping as well. Should you wish to modify the default values and fine tune your system for velocity mode, use the following procedures.



WARNING



This procedure causes the motor shaft to move. Make sure that shaft motion will not damage equipment or injure personnel.

Velocity Mode Tuning Procedure

Primary Tuning Procedure

1. Disable the drive.
2. Configure the drive for *velocity tuning mode* (DMODE16). In this mode, the drive commands an alternating 2 rps step change in velocity, at a one second repetition rate.
3. Enable the drive and observe your system's response. (If necessary, you can connect an oscilloscope as described in *Advanced Tuning* below.)

Ringling or an oscillating response indicates that the velocity loop bandwidth is too high. To eliminate oscillations:

- decrease bandwidth using the DVBW command.

A sluggish response indicates that velocity loop bandwidth is too low. To improve the response:

- increase bandwidth by using the DVBW command.

NOTE: Ringling, oscillations, or a sluggish response can also indicate inaccurate drive settings for LJRAT or LDAMP.

4. After you achieve a satisfactory system response, reconfigure the drive for velocity mode (DMODE4). This completes the primary tuning procedure.

If you are unable to achieve a satisfactory response, proceed to the advanced tuning procedure below.

Advanced Tuning Procedure

1. Disable the drive.
2. Configure the drive for *velocity tuning mode* (DMODE16). In this mode, the drive commands an alternating 2 rps step change in velocity, at a one second repetition rate.

(In some applications a different velocity profile may give better results. Choose a move similar to that required by your application, but using fast acceleration and deceleration rates. Be sure the maximum velocity of your move is well below the rated speed of your drive/motor combination.

A square wave generator connected to the velocity input (in DMODE4) may also be used.)

3. Configure ANALOG MONITOR A to show velocity setpoint, which is *commanded* velocity (DMONAV4).
4. Configure ANALOG MONITOR B to show *actual* velocity (DMONBV5)
5. Connect one channel of your oscilloscope to the drive's ANALOG MONITOR A (pin 21). Connect your oscilloscope's ground to the drive's ANALOG GROUND (pin 25).

6. Connect a second channel of your oscilloscope to the drive's ANALOG MONITOR B (pin 22). Connect your oscilloscope's ground to the drive's ANALOG GROUND (pin 25).

Adjust your oscilloscope to display commanded versus actual velocity. (The analog monitors can be scaled, in percent, with the DMONAS and DMONBS commands. You may need to set these to large values if the maximum velocity is small.)

7. Enable the drive and observe your system's response.

Ringling or an oscillating response indicates that the velocity loop bandwidth is too high, or the velocity loop damping is too low. To eliminate oscillations:

- decrease bandwidth using the DVBW command; then, if necessary:
- adjust damping by using the SGVRAT command. Use the value that gives the best performance.
- in applications with backlash or high static friction, disabling the velocity integrator (SGINTE0) can help improve stability.

A sluggish response indicates that velocity loop bandwidth is too low, or velocity loop damping is too high. To improve the response:

- increase bandwidth by using the DVBW command; then, if necessary:
- adjust damping by using the SGVRAT command. Use the value that gives the best performance.

NOTE: Ringling, oscillations, or a sluggish response can also indicate inaccurate drive settings for LJRAT or LDAMP.

8. OPTIONAL: Null the Input Offset

First: command zero volts by using either of two methods:

- Method 1: connect your controller or command voltage source, and command zero volts; or:
- Method 2: disconnect the controller or command voltage source, and short CMD+ to CMD- (pin 23 to pin 24).

Second: Issue a DCMDZ command to null any offset at the command input.

9. After you achieve a satisfactory system response, reconfigure the drive for velocity mode (DMODE4). This completes the advanced tuning procedure.

If ringling or oscillations persist, and do not seem to be affected by bandwidth adjustments, you may need to use notch filters or lead/lag filters. See the *Filter Adjustments* procedure at the end of this *Tuning* section.

Position Mode Tuning

For most applications, the default tuning parameters for velocity and position modes are set to provide good, stiff motor shaft performance for a given load setting. With the default tuning parameters set in the Express Setup procedure, you need only set the system load-to-rotor inertia ratio and your system will be tuned. If your system has significant mechanical damping, you may need to set the system damping as well. Should you wish to modify the default values and fine tune your system for position mode, use the following procedures.



WARNING



This procedure causes the motor shaft to move. Make sure that shaft motion will not damage equipment or injure personnel.

Position Mode Tuning Procedure

Primary Tuning Procedure

1. Disable the drive.
2. Configure the drive for *position tuning mode* (DMODE17). In this mode, the drive commands an alternating 1/4 revolution step change in position at a one second repetition rate.
3. Enable the drive and observe your system's response. (If necessary, you can connect an oscilloscope as described in *Advanced Tuning* below.)

Ringling or an oscillating response indicates that the position loop bandwidth is too high. To eliminate oscillations:

- decrease bandwidth using the DPBW command.

A sluggish response indicates that position loop bandwidth is too low. To improve the response:

- increase bandwidth by using the DPBW command.

NOTE: Ringling, oscillations, or a sluggish response can also indicate inaccurate drive settings for LJRAT or LDAMP.

4. After you achieve a satisfactory system response, reconfigure the drive for position mode (DMODE6, DMODE7, or DMODE8). This completes the primary tuning procedure.

If you are unable to achieve a satisfactory response, proceed to the advanced tuning procedure below.

Advanced Tuning Procedure

1. Disable the drive.
2. Configure the drive for *position tuning mode* (DMODE17). In this mode, the drive commands an alternating 1/4 revolution step change in position at a one second repetition rate.

(In some applications a different move profile may give better results. Choose a move similar to that required by your application, but using fast acceleration and deceleration rates. Be sure the maximum velocity of your move is well below the rated speed of your drive/motor combination.)
3. Configure ANALOG MONITOR A to show position error (DMONAV3).
4. Connect one channel of your oscilloscope to the drive's ANALOG MONITOR A (pin 21). Connect your oscilloscope's ground to the drive's ANALOG GROUND (pin 25).
5. Adjust your oscilloscope to display position error. (The analog monitor can be scaled, in percent, with the DMONAS command.)
6. Enable the drive and observe your system's response. Position error will increase during acceleration, but should decay smoothly to near zero without significant ringing or instability.

Ringling or an oscillating response indicates that the position loop bandwidth is too high, or the position loop damping is too low. To eliminate ringing or oscillations:

- decrease bandwidth using the DPBW command; then, if necessary:
- adjust damping by using the SGPRAT command. Use the value that gives the best performance.
- in applications with backlash or high static friction, disabling the velocity integrator (SGINTE0) can help improve stability.
- NOTE: In position mode, the velocity loop bandwidth tracks changes in position loop bandwidth by a ratio set by the SGPSIG command. In position mode, the DVBW command is ignored.

A sluggish response indicates that position loop bandwidth is too low, or position loop damping is too high. To improve the response:

- increase bandwidth by using the DPBW command; then, if necessary:
- adjust damping by using the SGPRAT command. Use the value that gives the best performance.

NOTE: Ringling or a sluggish response can also indicate inaccurate drive settings for LJRAT or LDAMP.

7. After you achieve a satisfactory system response, reconfigure the drive for position mode (DMODE6, DMODE7, or DMODE8). This completes the advanced tuning procedure.

If ringing or oscillations persist, and do not seem to be affected by the above adjustments, you may need to use notch filters or lead/lag filters. See the *Filter Adjustments* procedure below.

Filter Adjustments

If the previous tuning procedures did not eliminate ringing or oscillations, then mechanical resonances may be causing problems with your system's response.

Before trying the procedure below, we recommend that you check your mechanical system, especially the mechanical stiffness and mounting rigidity of your system. Use bellows or disk style couplers, not helical couplers. Once you have optimized your mechanical system, filters may allow increased performance, without causing system instability.

Filters can improve response by reducing system gain over the same frequencies that contain resonances. You can then increase the gain for frequencies outside this range, without exciting the resonance and causing instability.

The first procedure below describes how to set the drive's two notch filters, to reduce resonance and improve your system's response. The second and third procedures describe how to set the drive's lead and lag filters.



WARNING



These procedures cause the motor shaft to move. Make sure that shaft motion will not damage equipment or injure personnel.

Notch Filter Adjustment Procedure

1. Configure the analog monitor to show q-axis current (DMONAV19).
2. Configure the drive for torque mode (DMODE2).
3. Configure DMTLIM to approximately 1/3 of the default value for your Compumotor motor.
4. Connect one channel of your oscilloscope to the drive's ANALOG MONITOR A (pin 21). Connect your oscilloscope's ground to the drive's ANALOG GROUND (pin 25).
5. Connect a sine wave generator, with the amplitude set to minimum, to the drive's torque command input, pin 23. (Connect the signal generator's ground to the drive's CMD-, pin 24, and also to the drive's analog ground, pin 25.)
You may need to adjust the DC offset of the generator periodically to keep the load within its travel limit.
6. Slowly sweep the sine wave frequency, observing the oscilloscope or the load. Start at low amplitude, increasing gradually to a level that gives an observable response. Find the frequency that gives the maximum response. (If no oscilloscope is available, you may be able to find this frequency by sound or by touch).
7. Note the frequency that causes the maximum response.
8. Configure the drive for the appropriate tuning mode (torque, velocity, or position). Observe the system's response to the tuning mode's step input.
9. Set the notch filter to the frequency noted in Step 7 (DNOTAF command).
10. Using the DNOTAD command, slowly increase the depth of the notch filter from 0.0 to 1.0 until the ringing decreases.
11. Compare the response to a step input to the response you observed in *Step 8*. Ringing should be reduced or eliminated.

12. Adjust the Q of the filter (DNOTAQ command) until ringing is controlled, using the following guidelines:
 - Set Q as low as possible. Resonances change with load; therefore, your system will be more robust with a lower Q value.
 - If Q is too low, system stiffness will be reduced outside the resonant range.
 - If Q is too high, the response peak may merely shift in frequency.
13. After reducing the resonance, you may notice a second resonance. Use the second notch filter (DNOTBF, DNOTBD and DNOTBQ) to reduce the second resonance. Follow the same procedure as outlined in steps 1 – 10 above.
14. If you are done adjusting filters, reconfigure DMTLIM to its default value. Otherwise, proceed to the *Lag Filter Adjustment* procedure below.

Lag Filter Adjustment Procedure

The lag filter can act as a low pass filter, and reduce the effects of electrical noise on the command input signal in torque mode. (It can also reduce the effects of resonance at low frequencies—below 60 Hz—where the notch filters are not effective.)

1. As described in Steps 2 – 3 in the *Notch Filter Adjustment* procedure above, reduce DMTLIM and connect an oscilloscope.
2. Verify that the lead filter is turned off (DNOTLDØ).
3. Configure the drive for the appropriate tuning mode (torque, velocity, or position). Observe the system's response to the tuning mode's step input.
4. Choose a value for the lag filter (DNOTLG) that reduces low frequency resonance and provides satisfactory system performance.
5. If you are done adjusting filters, reconfigure DMTLIM to its default value. Otherwise, proceed to the *Lead/Lag Filter Adjustment* procedure below.

Lead/Lag Filter Adjustment Procedure

The lead filter can counteract the effects of the lag filter at higher frequencies. Do not use the lead filter by itself—if you use the lead filter, you must also use the lag filter.

1. As described in Steps 2 – 3 in the *Notch Filter Adjustment* procedure above, reduce DMTLIM and connect an oscilloscope.
2. Set the lag filter (DNOTLG) as described above.
3. Configure the drive for the appropriate tuning mode (torque, velocity, or position). Observe the system's response to the tuning mode's step input.
4. Choose a value for the lead filter (DNOTLD) that improves system performance. This value will typically be higher in frequency than the lag filter setting.
5. You must choose a value for the lead filter that is *higher* in frequency than the lag filter value. However, do not set the lead filter higher than four times the lag filter frequency, or a drive configuration warning will result, and the drive will use the previous filter settings.
6. If you are done adjusting filters, reconfigure DMTLIM to its default value.

CHAPTER FOUR

Special Features

IN THIS CHAPTER

- Relay
 - +24VDC Keep Alive Power Connections
 - Multiple Drive Installations
 - V BUS±
 - Regeneration Protection and the GPDM
 - Aligning the Resolver
 - RS-232/485 Communications
 - Updating the Drive's Operating System
-

Relay Connections (optional)

To use the drive's internal relay, connect your external circuit to the RELAY COM and RELAY N.O. terminals. The next drawing shows a typical application—connecting a motor brake to the relay terminals.

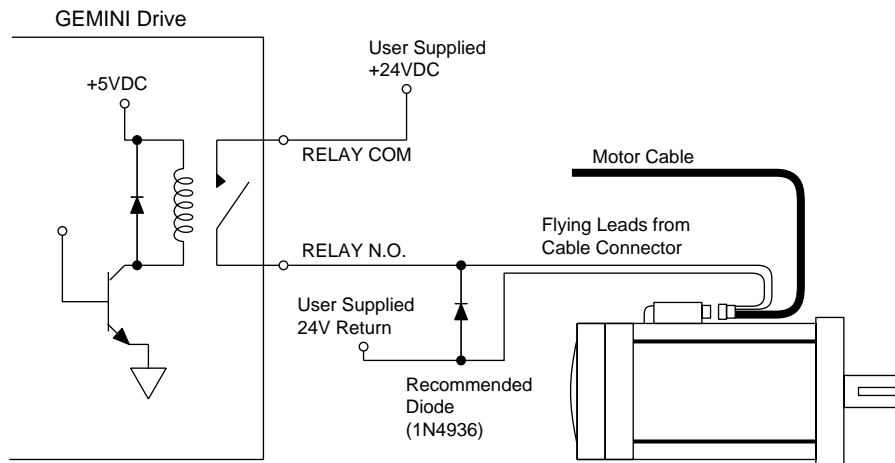

Relay Connections

The relay is normally open. When the drive is enabled, it holds the relay closed. If the drive faults or is disabled, the relay will open.

Relay Operation:

Drive Condition:

Enabled
 Faulted
 No AC power*, or not enabled

Relay State:

Closed
 Open
 Open

* +24VDC power does not affect the relay. With +24VDC applied, the relay will be open if AC power is *not* applied.

Relay Specifications:

Relay Type:

Dry contact mechanical relay
 Normally open

Relay Rating:

5 amps at 24VDC or 120VAC

+24VDC “Keep Alive” Power Connections (optional)

The following drawing shows how to connect an external +24VDC power source to the drive. Use the removable terminal connector that is supplied with the drive.

With +24VDC applied, the drive's internal control board will remain powered when the primary AC power source is disconnected, and will maintain several important functions, including communication diagnostics, position feedback, and other logic functions.

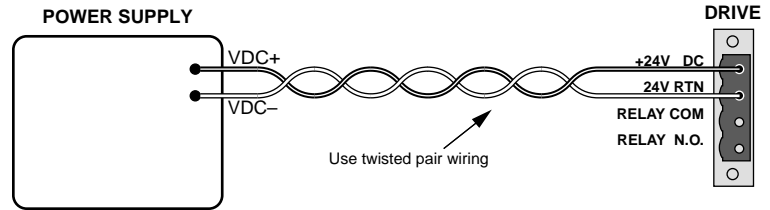

+24VDC Power Input

+24VDC Specifications:

Input voltage range:	19.2 – 28.8 VDC
Input current:	500 mA (minimum)
Functions powered under +24VDC:	position information (encoder or motor position counters in drive) communications diagnostics motor feedback program execution not involving motion (e.g., error programs, etc.)
Software status bit (see TASX command):	indicates “keep alive” is active: +24VDC power only (AC power is disconnected)

CAUTION

Do not exceed 28.8VDC input voltage

Multiple Drive Installations (optional)

Safety Earth Connections

For multiple drive installations, we recommend a single point or “star” safety earth configuration, as shown below.

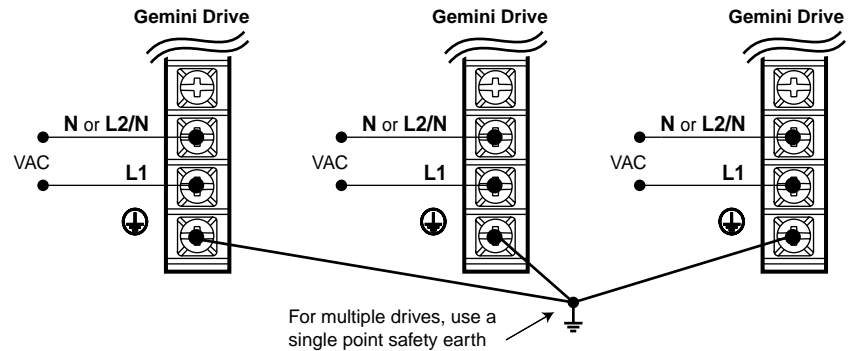

Multiple Drives: Single Point Safety Earth

Under normal operation, no current should flow through the safety earth connection.

Connecting V Bus±: Sharing the Power Bus (optional)

You can connect the power buses of Gemini GV-U3n/U6n/U12n/H40n drives in parallel, through the V BUS+ and V BUS- terminals. With the buses connected in parallel, regenerated energy from one drive will be used by the other drives. (Do *not* connect GV-H20n drives in parallel to each other or to other Gemini drives.)



WARNING



V BUS+ and V BUS- terminals are at hazardous voltages when power is applied to the drive, and for up to 30 seconds after power is removed. Lower voltages may still be present for several minutes after power is removed. Reinstall the clear plastic terminal cover after you make connections.



CAUTION



Connect together only V BUS± terminals of drives that share the same fused AC power source, as shown below.

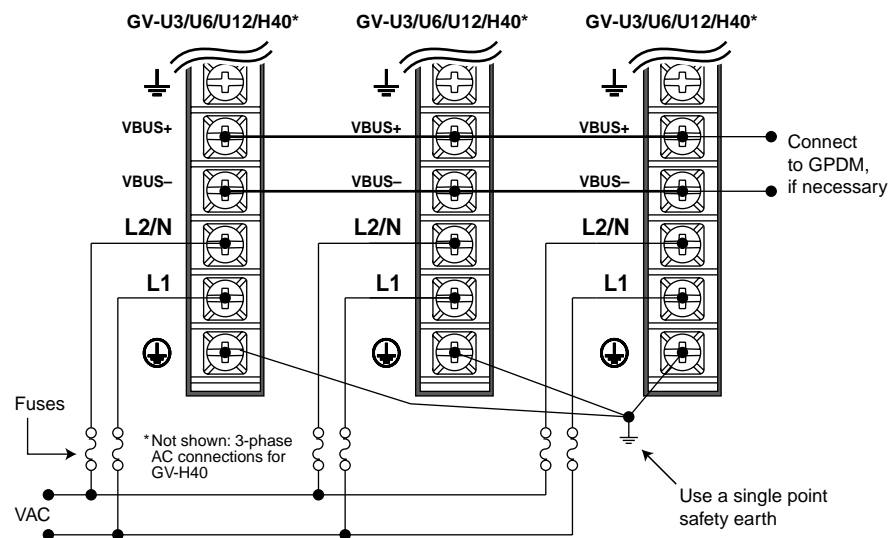

Sharing the Power Bus

If excess regenerated energy causes an overvoltage or regeneration fault, you can connect the Gemini Power Dissipation Module (GPDM) to the drive's V BUS± terminals. See *Regeneration Protection* below for connection instructions and more information about the GPDM.

NOTE: Because the Gemini drive has a current inrush limiter, we recommend that you do not add additional bus capacitance to V BUS+ and V BUS-.

Regeneration Protection

The following sections describe regeneration protection for Gemini drives, and the Gemini Power Dissipation Module.

Regeneration with GV-L3n/H20n/H40n

Gemini GV-L3n/H20n/H40n drives have internal circuitry to protect them from *regeneration*—energy from the load during deceleration. Excessive regeneration can cause either of two faults:

- Overvoltage Fault (see *Overvoltage Protection* in *Appendix A Specifications*)
- Regeneration Fault (if regeneration occurs for an extended period of time)

Specifications for regeneration protection are:

Drive	Dissipation (watts):	Maximum Pulse Energy	Activation Conditions	
			Turn on:	Turn off:
GV-L3n	8W continuous 500W peak	1.3 KJ	200VDC	193VDC
GV-H20n	25W continuous (100W continuous at 40°C) 6KW peak	6 KJ	396VDC	385VDC
GV-H40n	150W continuous 9KW peak	9 KJ	396VDC	385VD

Results of Fault: Latched fault; power to motor is turned OFF; fault output is activated
LEDs: Left = illuminated RED; Right = off

All temperatures in moving 50°C ambient air, unless otherwise noted.

Regeneration with GV-U3n/U6n/U12n

Gemini GV-U3n/U6n/U12n drives do not have internal regeneration circuitry. Consequently, they cannot cause a regeneration fault. The drives can absorb the following amounts of regenerated energy in their internal capacitors:

Drive	Absorb (joules):	
GV-U3n	44 J	(from 340 – 410VDC: 1680 µF)
GV-U6n/12n	59 J	(from 340 – 410VDC: 2240 µF)

If excess regenerated energy causes overvoltage faults, you can connect the Gemini Power Dissipation Module (GPDM) to the V BUS± terminals of these drives. Regenerated energy from the drive will then be dissipated in the GPDM.

Gemini Power Dissipation Module (GPDM)

The GPDM is designed for use with GV-U3n/U6n/U12n drives. (NOTE: If you use a GV-H20n/H40n drive, and regeneration in your application exceeds the dissipation capacity of the internal regeneration circuit (see above), you may connect a GPDM to dissipate the excess regenerated energy.)

The GPDM dissipates excess regenerated energy in its internal resistors. If regenerated energy from the motor causes the drive's DC bus voltage to increase to 398VDC, the GPDM connects its resistors in shunt across the DC bus. Energy in the drive's capacitors is then dissipated as heat in the GPDM's resistors.

When the DC bus voltage decreases to 380VDC, the GPDM disconnects its resistors. If the motor continues to regenerate energy and the bus again rises to 398VDC, the process repeats until regeneration stops or a fault occurs.

The GPDM monitors three parameters, and generates a fault if any of the following are exceeded:

- maximum duty cycle
- maximum temperature
- maximum energy pulse

If the GPDM faults, it will disconnect itself from the DC bus and illuminate its red LED. Its internal fan will continue blowing. The GPDM will automatically clear

the fault and reset itself within 10 seconds (an overtemperature fault may take longer to clear). When it resets itself, the GPDM will illuminate its green LED; the GPDM is then again ready to dissipate regenerated energy.

If regeneration continues while the GPDM is in a faulted state, the drive may experience an overvoltage fault. If you look for the cause of the drive overvoltage fault, be aware that it may have been caused by a prior GPDM fault—even though the left LED is now green.

If excessive regeneration continues to cause GPDM faults or drive faults, you can connect a second GPDM, as shown in the *GPDM Connections* drawing below.

GPDM Specifications

Activation Conditions:	Turn on: 398VDC Turn off: 380VDC
Resistance:	Six 100 ohm resistors in parallel (16.7 ohm equivalent)
Continuous Dissipation:	300W in 25°C internal ambient
Maximum Dissipation:	9KW
Maximum Pulse Energy:	13KJ (pulse rating of resistors, repeatable, not to exceed continuous rating)
Weight:	3.1 pounds (1.4 kg)

LED Color Code for GPDM:

Left:	Right:	Status:
Green	Off	ready
Green	Yellow*	active
Red	Off	fault (max. temperature, duty cycle, or pulse exceeded)

*Yellow LED may flash or be continuously illuminated until GPDM stops dissipating

GPDM Connection Instructions



WARNING



Sheet metal and exhaust air at the top of the enclosure are hot. Avoid contact.



WARNING



V BUS+ and V BUS- terminals are at hazardous voltages when power is applied to the drive, and for up to 30 seconds after power is removed. Lower voltages may still be present for several minutes after power is removed. Reinstall the clear plastic terminal cover after you make connections.



WARNING



Only connect V BUS± terminals of drives that share the same fused AC power source, as shown in the next drawing.

Connecting the GPDM

1. Connect up to three Gemini Servo Drives to one GPDM. (Connect only GV-U3n/U6n/U12n drives. Do not connect any other Gemini drives to the GPDM.)
2. Connect drive V BUS+ terminals to V BUS+ on the GPDM
3. Connect drive V BUS- terminals to V BUS- on the GPDM
4. For multiple drives, connect drive safety earth terminals to a single point ground.
5. Keep connections between drive and GPDM less than 12 inches (300 mm). Use 14 AWG (2.5 mm²) or greater diameter wire.

The next figure shows a typical installation.

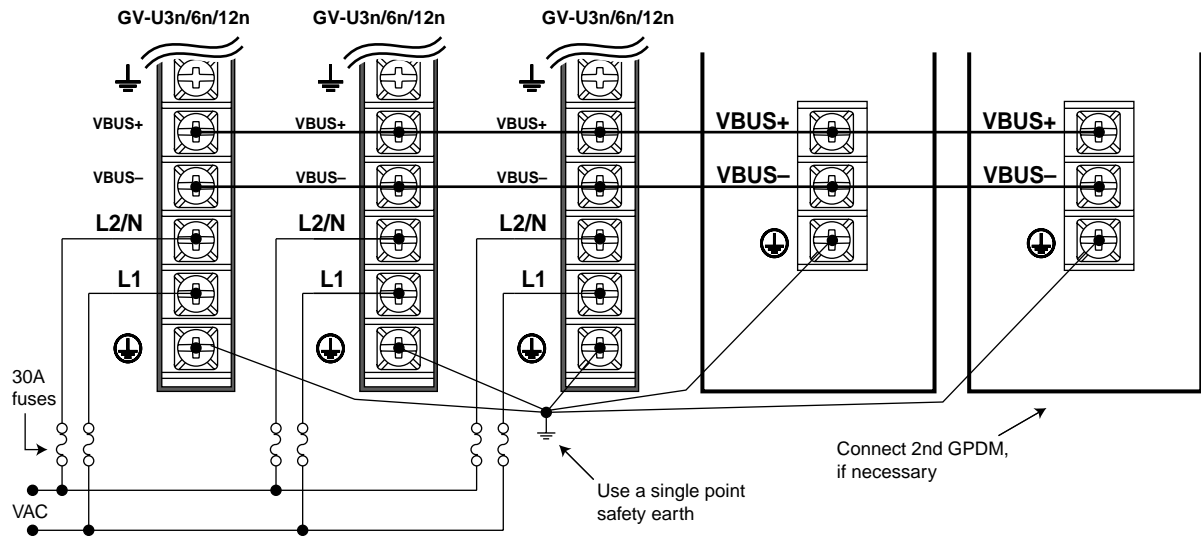

GPDM Connections

The next figure shows GPDM dimensions.

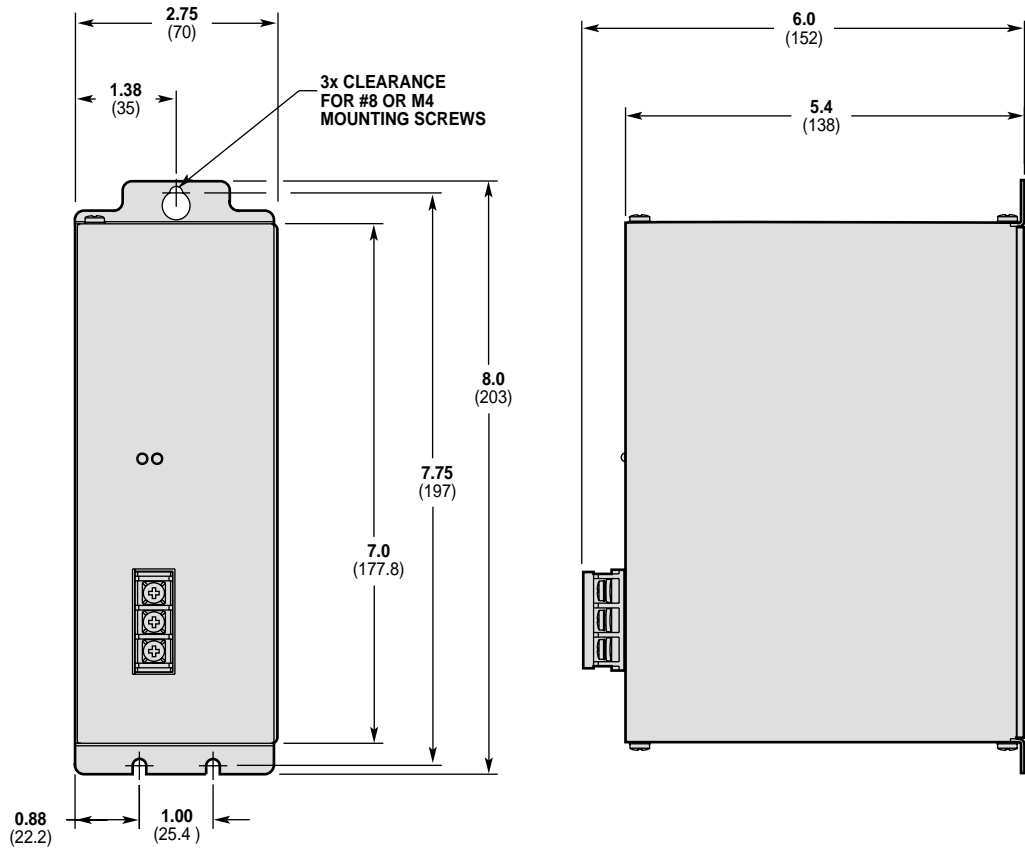

Dimensions – GPDM Power Dissipation Module

Aligning the Resolver (optional)

Resolvers on Compumotor motors are aligned at the factory. Ordinarily, no further alignment is required. However, you may wish to align the resolver if you suspect the resolver is misaligned, or if you are using a non-Compumotor motor.

A Note About Resolver Speed

Resolver speed describes the relationship between resolver *electrical* revolutions and shaft *mechanical* revolutions. For example, if one resolver electrical revolution is equal to one shaft mechanical revolution, the resolver is a “single speed” or “one speed” resolver. If two electrical revolutions equal one mechanical revolution, the resolver is a “two speed” resolver.

The following alignment procedures assume you have configured the drive with an accurate resolver speed value. For Compumotor motors, resolver speed is loaded from the motor configuration file.

Resolver Alignment Procedures

There are three methods to align the resolver:

- Method 1 – Enter a known resolver offset angle.
- Method 2 – Find an unknown resolver offset angle, and store it in the drive's nonvolatile memory.
- Method 3 – Loosen the resolver cleats and rotate the housing while monitoring offset angle. Secure the housing when the angle is zero degrees.

Details for these methods are given below.

Method 1 – Entering a Known Offset Angle

1. Disconnect the load from the motor shaft. The shaft should be free to rotate.
2. Issue an SRSET command; include the desired offset angle. For example, entering SRSET10 automatically sets the offset angle to 10 degrees.



WARNING



The SRSET command takes effect immediately. If you set the offset angle incorrectly the system may become unstable.

3. Disable the drive. Upon being disabled, the drive stores the value for the offset angle into nonvolatile memory. It uses this value for all future operations. You do not need to perform this procedure again.

Method 2 – Finding an Unknown Offset Angle

Use this method if you do not know your resolver's offset angle.

1. Disconnect the load from the motor shaft. The shaft should be free to rotate.
2. Verify correct motor wiring. See the *Gemini Motor Reference Manual* for wiring information for Compumotor motors.
3. Configure the drive for your motor, as described in *Chapter 2 Installation*. If you use a non-Compumotor motor, create and download a motor configuration file for your motor.
4. Enable the drive.
5. Issue a DMODE13 command to put the drive into autorun mode. The motor should begin turning clockwise at approximately 1 rps, as viewed from the shaft end of the motor. If the motor turns in the wrong direction or at the wrong speed, check the motor wiring, and verify correct motor pole configuration (DPOLE command).
6. Issue a DMODE11 command to put the drive into alignment mode. The motor will stop turning.
7. Issue an SRSET command. The motor may turn as much as 1/2 revolution. It will stop when the motor magnetic poles align.
8. Disable the drive. Upon being disabled, the drive stores the value for the offset angle into nonvolatile memory. It uses this value for all future operations. You do not need to perform this procedure again.
9. Return the drive to the appropriate mode of operation (DMODE command).

Method 3 – Rotating the Resolver Housing

Use this method to manually rotate the resolver to a specific offset angle (usually zero degrees).

1. Disconnect the load from the motor shaft. The shaft should be free to rotate.
2. Verify correct motor wiring. See the *Gemini Motor Reference Manual* for wiring information for Compumotor motors.
3. Configure the drive for your motor, as described in *Chapter 2 Installation*. If you use a non-Compumotor motor, create and download a motor configuration file for your motor.
4. Enable the drive.
5. Issue a DMODE13 command to put the drive into autorun mode. The motor should begin turning clockwise at approximately 1 rps, as viewed from the shaft end of the motor. If the motor turns in the wrong direction or at the wrong speed, check the motor wiring, and verify correct motor pole configuration (DPOLE command).
6. Issue a DMODE11 command to put the drive into alignment mode. The motor will stop turning.
7. Issue an SRSET command. The motor may turn as much as 1/2 revolution. It will stop when the motor magnetic poles align.
8. Loosen the cleats that hold the resolver housing onto the motor.
9. Issue a TSROFF command repeatedly as you slowly turn the resolver housing. The TSROFF command indicates the present resolver offset angle.
10. Turn the resolver housing until the offset angle is zero degrees (or until you obtain your desired offset angle).
11. Tighten the cleats.
12. Disable the drive. Upon being disabled, the drive stores the value for the offset angle into nonvolatile memory. It uses this value for all future operations. You do not need to perform this procedure again.
13. Return the drive to the appropriate mode of operation (DMODE command).

RS-232/485 Communications

The Gemini drive has a single serial port marked, “RS-232/485,” on the front of the unit. In the following this port will be referred to as the COM port. The Gemini drive uses a binary language for communication; it does not use ASCII. To enable 6000 ASCII level communication in a terminal mode, the Gemini uses a translator utility in Pocket Motion Planner and in the CommServer (for use with Motion Planner). In all other ways, the serial communication functions in the Gemini behave like other Compumotor products. Gemini drives can be connected together in RS-232 Daisy Chains and RS-485 Multi-Drop configurations.

In this section:

- Establishing Communications
- Configuring the serial port
- RS-232 Communications
- RS-232 Daisy Chaining
- RS-485 Communications
- RS-485 Multi-Drop

Establishing Communications

The drive’s configuration port is a 9 pin D-connector. You can use it for either RS-232 or four wire RS-485 communications, as shown in the next drawing.

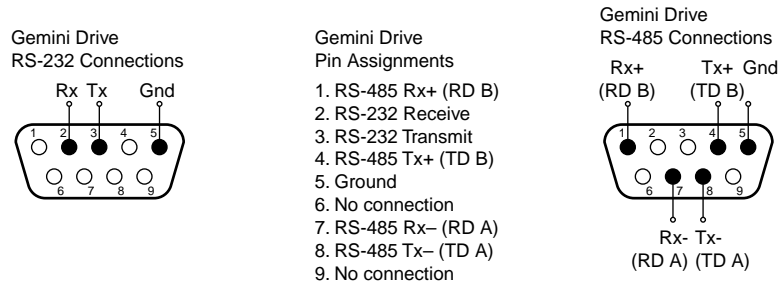

RS-232/485 Connections

To communicate with the drive, connect the drive’s RS-232/485 connector to a PC running Motion Planner, or to a palm PC running Pocket Motion Planner with Windows CE. Verify your computer’s connector pinout; you may need to use a “null modem” cable to connect your computer’s transmit terminal to the Gemini’s receive terminal, your computer’s receive terminal to the Gemini’s transmit terminal, and your computer’s ground terminal to the Gemini’s ground terminal.

Configuring the Serial Port

The following commands can be used to configure the Gemini serial port and the terminals used by Motion Planner and Pocket Motion Planner. Complete descriptions of these commands can be found in the *Gemini Programmer's Reference*.

E	Enable Serial Communication
ECHO	Enable Communication Echo
BOT	Beginning of Transmission Characters
EOT	End of Transmission Characters

EOL End of Line Terminating Characters
 ERRBAD Error Prompt
 ERRLVL Error Detection Level
 ERROK Good Prompt

- The baud rate for the Gemini is set at 9600. Future releases of Gemini firmware will offer additional baud rate choices. Check the Compumotor web site (www.compumotor.com) for information on new software releases.
- The Gemini serial port contains connections for both RS-232 and RS-485 communication. The Gemini drive will automatically switch between RS-232 and RS-485 mode depending on which connections in the port's 9 pin D-connector are active. See wiring diagrams.
- Some RS-232 cables use hardware handshake signals that are used by the RS-485 pins. The RS-485 interface will automatically disable itself if this is detected. If this occurs, you must reset the drive to re-enable the RS-485 interface.

RS-232 Communications

Pin Out for RS-232 Communication:

Pin Description

- 2 Rx (receive). Connect to Tx on your computer.
- 3 Tx (transmit). Connect to Rx on your computer.
- 5 GND (logic ground). Connect to GND on your computer

- Maximum RS-232 cable length is 50 feet (15.25 meters)
- To establish unique addresses for daisy-chained units, use the ADDR command.

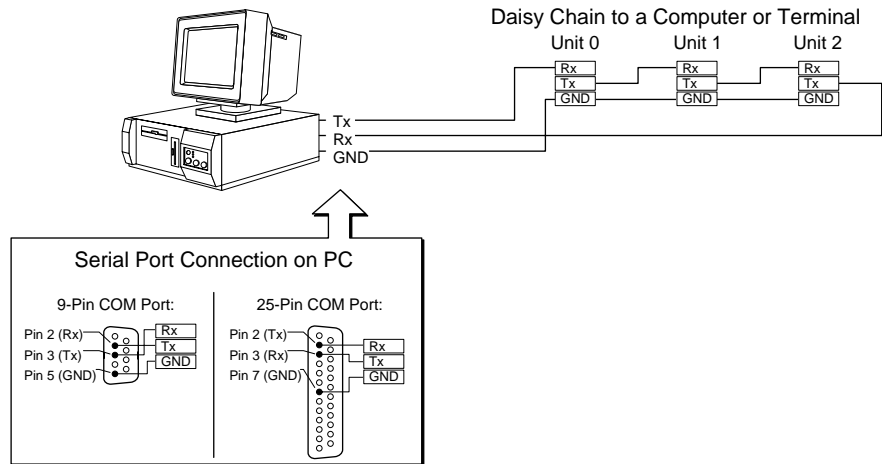

RS-232 Daisy Chain Connections

RS-232 Daisy-Chaining

Up to ninety-nine stand-alone Gemini drive products may be daisy-chained. Refer to the wiring diagrams for daisy-chain connections.

Follow these steps to implement daisy-chaining:

Step 1

Connect the daisy-chain with a terminal as the master. (See the previous drawing.)

To enable and disable communications on a particular drive unit in the chain, you must use the Daisy-Chain Address (ADDR) command to establish a unique device

address for each unit. The ADDR command automatically configures unit addresses for daisy chaining. This command allows up to 99 units on a daisy chain to be uniquely addressed.

Sending ADDR i to the first unit in the daisy chain sets its address to be i . The first unit in turn transmits ADDR $(i + 1)$ to the next unit to set its address to $(i + 1)$. This continues down the daisy chain until the last unit of (n) daisy-chained units has its address set to $(i + n)$.

Note that a drive with the default device address of zero (0) will send an initial power-up start message similar to the following:

```
*TREV-GV-L3E_D1.0_F1.0
```

Step 2

To allow daisy chaining you must turn on echo mode for each drive on the chain (ECHO1). The ADDR command automatically leaves each device in echo mode after the device address is set when in RS-232 mode.

In the Gemini, daisy chaining can work in all error levels except error level 0 (see ERRLVL command). To set the drive error levels to your preferred state you can address each drive individually or send a global command. Note the address syntax used to send data to particular units:

Commands:

```
1_ERRLVL4      ; Set error level to 4 for unit #1
2_ERRLVL4      ; Set error level to 4 for unit #2
ERRLVL4        ; Set error level to 4 for all units on the chain
```

Unlike ASCII-based products, the binary prompts associated with the different error levels can pass through the daisy chain to the terminal controller without interfering with the other drives. At that point they are translated into the text strings defined by the ERROK and ERBAD commands. Consequently, error levels using prompts can be used in Gemini daisy chains.

To receive data from a particular drive on the chain, you must prefix the command with the appropriate unit's device address and an underline:

Commands:

```
1_ERES          ; Request encoder resolution from unit #1
*ERES4000       ; Response from unit #1
```

Use the E command to enable/disable RS-232 communications for an individual unit. If all drive units on the daisy chain are enabled, commands without a device address identifier will be executed by all units. Because of the daisy-chain's serial nature, the commands will be executed approximately 1 ms per character later on each successive unit in the chain (assuming 9600 baud).

Units with RS-232 disabled (EØ) will not respond to any commands, except E1; however, characters are still echoed to the next device in the daisy chain.

Commands:

```
3_E0            ; Disable RS-232 on unit #3
ERES2000        ; Set encoder resolution to 2000 on all other units
3_E1            ; Enable RS-232 on unit #3
3_ERES4000      ; Set encoder resolution to 4000 on unit #3
```

Verify communication to all units by using the techniques described above.

Step 3

Now that you have verified that the daisy chain is set up properly, you can use the various Pocket Motion Planner and Motion Planner tools to configure and monitor all units on the daisy chain.

RS-485 Communications

Pin Out for 4-Wire RS-485 Communications:

Pin	Description
1	Rx+ (also called RD B)
4	Tx+ (also called TD B)
5	GND (logic ground)
7	Rx- (also called RD A)
8	Tx- (also called TD A)

- Maximum RS-485 cable length is 4000 feet (1220 meters).
 - To establish unique addresses for multi-drop units, use the ADDR command.
 - Keep wires as short as possible. Termination resistors may be required on long cable runs.
 - Connect RS-485 cables before applying power to the drive.
- (Reconnecting the cables with power applied may cause the drive to interpret intermittent connections as RS-232 hardware handshake signals; this may result in shutdown of the RS-485 interface. If this happens, reset the drive to re-enable the RS-485 interface.)
- Recommended cable: Belden 9842.
 - Refer to the diagram below for connection information.

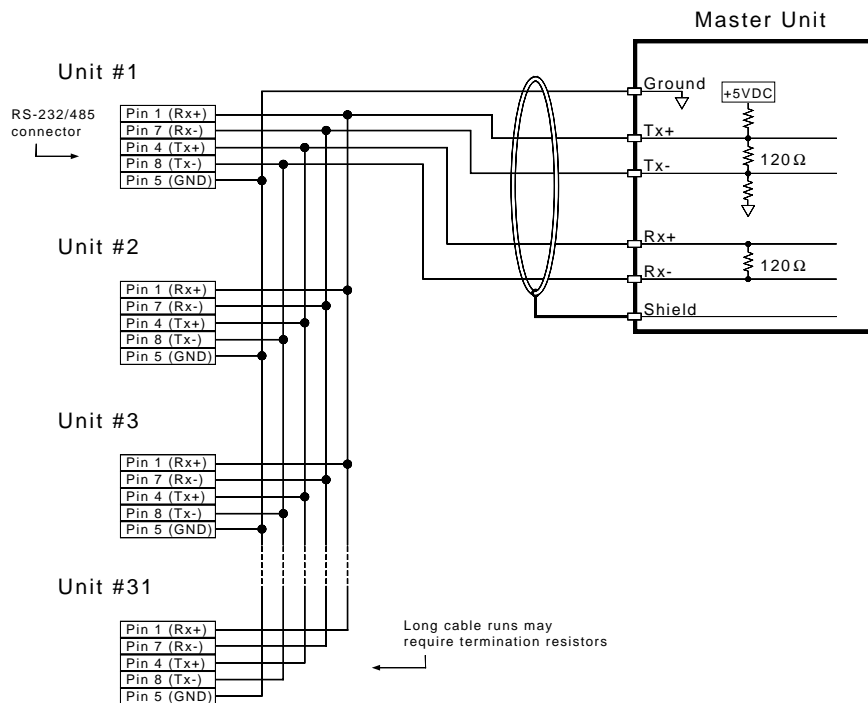

RS-485 Multi-drop Connections

RS-485 Multi-Drop

Up to 99 Gemini drives may be multi-dropped. (See the previous drawing.)

The ADDR command allows you to establish up to 99 unique addresses. To use

the ADDR command, you must address each unit individually before it is connected on the multi drop. For example, given that each product is shipped configured with address zero, you could set up a 4-unit multi-drop with the commands below, and then connect them in a multi drop:

1. Connect the unit that is to be unit #1 and transmit the Ø_ADDR1 command to it.
2. Connect the unit that is to be unit #2 and transmit the Ø_ADDR2 command to it.
3. Connect the unit that is to be unit #3 and transmit the Ø_ADDR3 command to it.
4. Connect the unit that is to be unit #4 and transmit the Ø_ADDR4 command to it.

If you need to replace a unit in the multi drop, send the Ø_ADDRi command to it, where “i” is the address you wish the new unit to have. For RS-485 multi-drop to work properly, each drive must have echo mode turned off (ECHOØ).

In order to prevent the collision of prompts being transmitted simultaneously from several drives in response to a global command, you must configure the drives for either error level 2 or error level 0 in multi-drop mode. This can be done as follows:

Commands:

```
1_ERRLVL2      ; Set error level to 2 for unit #1
2_ERRLVL2      ; Set error level to 2 for unit #2
3_ERRLVL2      ; Set error level to 2 for unit #3
```

In general, to send a Gemini command from the master unit to a specific unit in the multi-drop, prefix the command with the unit address and an underscore (e.g., 3_ERES4000 sets the encoder resolution to 4000 on unit #3). The master unit may receive data from a multi-drop unit. You should now verify that you can access each unit on the multi-drop.

Now that you have verified that the multi-drop is set up properly, you can use the various Pocket Motion Planner and Motion Planner tools to configure and monitor all units on the multi-drop.

Updating the Drive's Operating System

The Gemini drive runs under an internal software operating system (firmware). The operating system was loaded into your drive during the manufacturing process, and under ordinary circumstances you will not need to update your drive's operating system. However, because Compumotor continues to add enhancements, you may want to upgrade the operating system. You may obtain a new operating system file from the Compumotor web site, or from Technical Support (see phone numbers on the inside cover of this manual).

For more information about web site downloads and update procedures, see the *Gemini Programmer's Reference*.

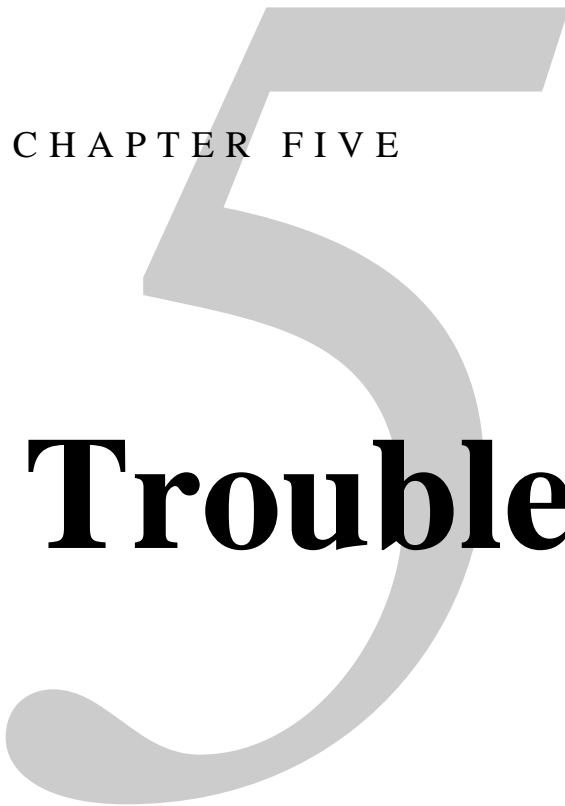

CHAPTER FIVE

Troubleshooting

IN THIS CHAPTER

- LED Status
 - Software Commands for Troubleshooting
 - RS-232/485 Troubleshooting
 - System Problems
-

Troubleshooting Guidelines

If your system is not functioning properly, first try these steps.

First Troubleshooting Steps:

- Is the left LED illuminated? If not, look for problems with AC power. Also see *System Problems* at the end of this chapter.
- Is the left LED illuminated RED? Try to enable drive by connecting pins 1 and 2 of the 50 pin DRIVE I/O connector. If you have a controller connected, this is usually done by sending a DRIVE1 to the controller.
- Cycle power to the drive. Cycling power clears most faults. Notice if the LED turns green, or if it goes directly from off to red.
- Check wiring and feedback connections

If these steps do not solve your problem, follow the general troubleshooting procedure outlined below:

General Troubleshooting Procedure

- Check the LEDs (see the chart below)
- Launch Motion Planner or Pocket Motion Planner
- Verify good RS-232/485 communications
- Save the configuration file
- Use software commands for problem identification:
 - TERRLG reports the last 10 error conditions
 - TAS reports on axis status
 - TASX extended reports on axis status and conditions
 - TCS reports codes for specific faults and warnings
- Look for non-Drive problems (problems with other parts of the system)

Detailed procedures for each of these topics are given in the rest of this chapter.

LEDs

The drive has two LEDs. The LED on the left can be red or green. The LED on the right can be yellow or green. LED illumination states, and the conditions they indicate, are tabulated below.

Left LED (Green/Red)	Right LED (Yellow/Green)	Indicated Condition:
off	Yellow	Initialization
Red (flashing)	off	Awaiting flash download
Red (flashing)	Yellow (flashing)	Programming flash memory
Red	Green	Keep Alive mode
Green	Green (flashing)	Incoming steps (variable rate)
Green	Yellow/Green (flashing)	Autorun mode
Red	off	Drive not enabled; or, Drive faulted
Green	off	Drive ready

Establish Communications and Verify Drive Configuration

If you cannot enable the drive, and examining LED conditions has not solved your problem, then establish communications with the drive and launch Motion Planner or Pocket Motion Planner. (See *Chapter 2 Installation* for detailed instructions on establishing communications. Information about installing and using these software programs can be found in the *Gemini Programmer's Reference*.)

If you are unable to establish communications, see *RS-232/485 Communication Problems* later in this chapter.

Save the Configuration File

Since further troubleshooting steps may change the drive configuration, you should upload the current drive configuration file and save it to your PC, in case you need it for future reference.

Reconfigure the Drive

To verify proper configuration, you may wish to reconfigure the drive. Pay particular attention to selecting proper configuration settings for the motor that you have installed, as motor configuration problems can cause a variety of errors. Download the new configuration to the drive; the changes will become effective after you RESET or cycle power. (A simplified configuration procedure was presented in *Chapter 2 Installation*. For full configuration information, see *Chapter 3 Configuration*.)

Software Commands for Troubleshooting

Four software commands are very useful for identifying problems. This section provides guidelines and tips for using these commands. For full command descriptions and tables of error codes, see the *Gemini Programmer's Reference*.

TERRLG – Transfer Error Log

The TERRLG command displays the last ten error conditions. It is updated every time an error occurs; you may want to make a note of the errors listed the first time you issue the command, as this original information will be written over as subsequent errors occur.

You can use the CERRLG command to clear the contents of the error log. This allows you to start the diagnostic process when the error log is in a known state.

TAS – Transfer Axis Status

The TAS command returns the status of all axes, in the form of a 32 bit response: 1 = Yes; 0 = No. (Use the TASXF command for a text-based status report). Note the positions of bits that are “1” rather than “0”—they indicate problem areas, some of which are:

Status Condition:	Solution:
Drive shut down	If this is the only bit that is set, it indicates that the drive is waiting to be enabled. To enable the drive, connect pins 1 and 2 of the DRIVE I/O connector—usually done by sending a DRIVE1 to the controller.
Drive faults occurred	To identify which faults occurred, check the TASX command. (See following section.)
Hardware limit hit	The default is for limits to be disabled. If these bits are set, install or check limit switches; or disable limits with the LH0 command.
Position error exceeded	During tuning, you may want to disable position error by setting SMPER to zero. To help protect the motor from damage, restore SMPER to an appropriate value when you complete tuning.

See the *Gemini Programmer's Reference* for the complete list of status conditions.

TASX – Transfer Extended Axis Status

The TASX command returns the axis status conditions. It reports more information than the TAS command, and is helpful for identifying which faults occurred. It returns a 32 bit response: 1 = Yes; 0 = No. (Use the TASXF command for a text-based status report). Note the positions of bits that are “1” rather than “0”—they indicate problem areas, some of which are:

Bit #:	Fault:	Solution:
1	Motor temperature fault	Thermal switch in motor is open; motor is hot
2	Low voltage fault	Check acceleration; AC power wiring and input level
3	Drive temperature fault	Check ventilation; ambient temperature
5	Resolver failed	Check resolver wiring.
7	Configuration error	Drive cannot operate as configured. See TCS command, below.
8	Incoming steps at startup	Stop indexer pulses.
9	Velocity error limit exceeded	Check mechanics for jam; check tuning. Raise limit.
10	Bridge fault	Check motor wiring for short circuit. (See note below.)
11	Bridge I ² t fault	Current model indicates bridge is hot.
12	Overvoltage (bus voltage)	Reduce deceleration (or install GPDM for regeneration on GV-U3n/U6n/U12n).
18	Override mode invoked	Velocity override (torque mode) or torque override (velocity mode) was invoked. Check mechanics. (Warning only: does not light LED or stop motion.)
19	Bridge foldback	Output current was reduced, to decrease dissipation. (Warning only: does not light LED or stop motion.)
20	Power Dissipation active	GV-L3n, GV-H20n, GV-H40n only. Internal regeneration circuit was active. Check deceleration. (Warning only: does not light LED or stop motion.)
21	Bad Hall state	Bad state (111 or 000) was detected. Check Hall wiring.
22	Unrecognized hardware	Consult factory
23	User fault	Indicates input #3 was active.
24	Keep Alive active	Not a fault; indicates +24VDC power at +24VDC input.
25	Power dissipation fault	Indicates excessive regeneration (GV-L3n, GV-H20n, GV-H40n only). Check deceleration, load inertia.
28	Configuration warning	Drive altered a user entered value. See TCS command. (Warning only: does not light LED or stop motion.)
29	Encoder output failure	ORES is set too high for maximum velocity commanded
30	Motor thermal model fault	Thermal model indicates motor is hot
31	Torque/force is at limit	Commanded torque/force has reached limit set by DMTLIM (TTRQ = DMTLIM). Not a fault condition.

(NOTE: Bridge fault can also indicate output bridge overheating (except in GV-L3n). To test, check drive heatsink temperature; allow drive to cool, then reset drive. If fault remains, it is due to a short circuit—check motor and motor wiring. If fault reoccurs after several minutes, it may be due to restricted airflow over the drive's heatsink.)

See the *Gemini Programmer's Reference* for the complete list of status conditions.

TCS – Transfer Configuration Status

If the TASX command indicates a configuration error or warning, use the TCS command to help ascertain the cause of the condition.

NOTE: TCS reports only one error code; errors will overwrite warnings. Therefore, if there is more than one error condition present:

1. Resolve the known error.
2. Cycle power to the drive, issue a RESET command, or activate the RESET input.
3. If another error condition presents itself (e.g., the drive will not enable), check for subsequent errors with the TCS command.

See the *Gemini Programmer's Reference* for the complete list of faults and warnings.

RS-232/485 Communication Problems

If you cannot establish RS-232 or RS-485 communications, the next sections give instructions for procedures to help isolate problems.

Testing the COM Port

Install and launch either Motion Planner or Pocket Motion Planner. See *Chapter 2 Installation* for information about using these software tools.

RS-232 communications require that you use a null modem cable. See *Chapter 2 Installation* for connection instructions. Pinout diagrams for the Gemini's RS-232/485 connector is in *Chapter 4 Special Features*.

Testing the COM Port with Motion Planner

If you use Motion Planner, follow these steps.

1. Install and launch Motion Planner.
2. When the product selection dialog appears, select a Gemini drive and select the COM port to which the Gemini is connected.
3. If you see the error message "unable to connect to com *n*", then the wrong PC COM port is selected, or the PC COM port is busy.
 - Check the PC COM port setting again. Your PC may have multiple COM ports. Try connecting to a different port.
 - Check to see if another application is busy using the COM port. Close all other applications.
 - Try connecting to a different port.
 - Check AC power to the drive. (The drive's left LED should be illuminated, either red or green.)

If these steps do not solve your problem, see *Testing the Cable*, below.

Testing the COM Port with Pocket Motion Planner

If you use Pocket Motion Planner, follow these steps.

1. Install and launch Pocket Motion Planner.
2. From the "Communications" menu, select "Com Port", and select an appropriate com port.
3. From the "Communications" menu, select "Test Com Port".
4. You will see one of the following responses:
 - If the response is "Communications OK!", then:
 - communications are working properly.
 - If the response is "Communications problem found", then:
 - Verify the drive is powered up
 - Verify the RS-232 cable is connected to the drive
 - Check your com port settings within Pocket Motion Planner
 - Make sure no other programs or hardware are trying to use this com port.

If these steps do not solve your problem, see *Testing the Cable*.

Testing the Cable

Use the following two procedures to test your null modem cable, and verify that it is working properly.

“Loop Back” Test

1. Connect one end of your RS-232 cable to your PC, palm PC, or HPC. Disconnect the other end of the cable from the drive.
2. Connect pin 2 to pin 3 on the drive end of the RS-232 cable.
3. Launch Pocket Motion Planner and select “Test Com Port” from the “Communications” menu.
4. If you receive a “Communications OK!” response, your cable is good.
5. Under “Tools”, select “Terminal Emulator”. Under “Options”, select “Show Hex.”
6. With pins 2 and 3 at the drive end of your null modem cable *open*, typing “DRES” in the terminal will produce the response “DRES 0A00”.
7. With pins 2 and 3 at the drive end of your null modem cable shorted, typing “DRES” in the terminal will produce the response “DRES 0A00 0A00”.

If you are continuing to have trouble with communications, proceed to *Verifying a Null Modem Cable*.

Verifying a Null Modem Cable

1. Connect one end of your RS-232 cable to your PC, palm PC, or HPC. Disconnect the other end of the cable from the drive.
2. With no data being transmitted, measure the voltage on the RS-232 cable’s transmit pin (should be pin 2). The voltage on the transmit pin should be in the range -3VDC to -12VDC.
3. Measure the voltage on the RS-232 cable’s receive pin (should be pin 3). The voltage on the receive pin should be zero volts.
4. Verify that the cable’s transmit pin connects to Pin 2 on the Gemini’s RS-232/485 connector.

This completes the test.

RS-232 Daisy Chain Guidelines

All drives in an RS-232 daisy chain must be configured as follows:

- Echo must be on (ECHO1)
- Error level must be set to a value greater than 0. (See ERRLVL command).

For more information about RS-232 daisy chain problems, see *RS-232/485 Communications in Chapter 4 – Special Features*.

RS-485 Multi-Drop Guidelines

All drives in an RS-485 multi-drop must be configured as follows:

- Echo must be off (ECHO0)
- Error level must be set to either 2 or 0. (See ERRLVL command).
- Connect RS-485 cables before applying power to the drive.

For more information about RS-485 multi-drop problems, see *RS-232/485 Communications in Chapter 4 – Special Features*.

System Problems

If your Gemini drive is functioning properly, other parts of your system may be causing problems. It may be difficult to identify where the problem is coming from. To diagnose system problems, we recommend that you first have the drive perform its autorun function. Then check the other topics in this section.

Using Autorun Mode to Isolate Problems

In autorun mode, the motor runs open loop—the Gemini drive generates its own internal control signal, and commands the motor to turn clockwise at 1 rps.

NOTE: In autorun mode, the drive limits current to 90% of drive rating or continuous motor current rating, whichever is lower.

Follow these steps to put the drive in autorun mode, which will verify that the drive is functioning properly, and is not the source of the problem.

1. Disconnect the controller from the drive. Disconnect the load from the motor.
2. Perform these procedures from *Chapter 2 Installation*:
 - Connect the Motor (power and feedback)
 - Connect AC Power
 - Configure the Drive

The final step in “Configure the Drive” is issuing a DMODE13 command, which configures the drive for autorun.

3. Enable the drive by connecting Pin 1 to Pin 2 on the drive's 50 pin DRIVE I/O connector. NOTE: connecting pin 1 to pin 2 may require that you use a breakout module, such as Compumotor's GEM-VM50.
4. Apply AC power.
5. The motor should begin turning clockwise at one revolution per second.

Successful completion of the autorun test indicates that AC power and motor cables are connected correctly, and that the drive is functioning properly. Check the topics below for other sources of problems.

AC Power

Verify that your AC power mains deliver adequate power to the drive's AC power input.

Motor Problems

Verify that the drive is configured properly for the motor you are using. The motor series, frame size, and part number information on a Compumotor motor's name plate should match the settings stored in the drive's memory.

Motor Brake

If you are using a motor with a brake, verify that the brake is connected properly, and that it is functioning as intended.

Motor Resolver

Resolvers on Compumotor motors are aligned at the factory. Ordinarily, no further alignment is necessary. However, if you suspect that the resolver has been altered and is out of alignment, you can follow the alignment procedure in *Aligning the Resolver*, located in *Chapter 4 Special Features*.

Mechanical System

Shaft Coupler

Verify that the shaft coupler is not slipping during acceleration or deceleration. We recommend bellows or disk style couplers for servo applications. Helical couplers are inadequate, and are *not* recommended.

Mechanical Transmission

Verify that your mechanical system functions properly, and is not jammed.

Motion Problems

If problems occur during motion, check these possible causes:

- Motor Sizing (ensure that the motor has enough torque to perform the move)
- Excessive Acceleration or Deceleration
- Excessive Velocity

Electrical Noise

Electrical noise on input or output lines can cause stop or kill inputs to activate unexpectedly. See *Appendix C: Regulatory Compliance* for installation guidelines on reducing electrical noise.

Software/Motion Program Problems

Check to see that your motion programs are functioning properly, and are not causing unexpected problems.

APPENDIX A

Specifications

IN THIS CHAPTER

- Gemini Drive Specifications
 - Input/Output Specifications
 - Dimensions
 - Protective Circuits
 - Cable Specifications
-

Power Specifications

+24VDC Input Power (Optional “Keep Alive” Power)

Input voltage range: 19.2 – 28.8 VDC
 Input current: 500 mA (minimum)

AC Input Power

AC

Drive	AC Input Voltage
GV-L3n	95VAC – 132VAC, 1-phase, 50/60 Hz
GV-U3n	95VAC – 264VAC, 1-phase, 50/60 Hz
GV-U6n	95VAC – 264VAC, 1-phase, 50/60 Hz
GV-U12n	95VAC – 264VAC, 1-phase, 50/60 Hz
GV-H20n	165VAC – 264VAC, 1-phase or 3-phase, 50/60 Hz
GV-H40n	165VAC – 264VAC, 3-phase, 50/60 Hz



CAUTION



Do not operate GV-L3 above 132VAC, or the drive will be permanently damaged.

Connector:	GV-L3/U3/U6/U12/H20:	GV-H40n:
Drive terminals:	#8 (M4) screw terminals	#10 (M5) screw terminals
Mating terminals:	spade fork, 0.325" max. width	ring terminal, 0.25" I.D., 0.50" O.D.
Tightening torque:	20 in-lbs nom., 24 in-lbs max.	20 in-lbs nom., 24 in-lbs max.

Output Power

Drive	Continuous Output:		Peak Output:	
	Current (amps, peak)	Power (watts, max)	Current (amps, peak)	Power (watts, max)
GV-L3n	3A	440W	7.5A	1.1 kW
GV-U3n	3A	880W	7.5A	2.2 kW
GV-U6n	6A (at 8 kHz)	1.75 kW	15A (at 8 kHz)	4.4 kW
GV-U12n	12A (at 8 kHz)	3.5 kW	30A (at 8 kHz)	8.8 kW
GV-H20n	20A (3Ø input at 8 kHz)	5.8 kW	50A (3Ø input at 8 kHz)	14.7 kW
GV-H40n	40A (3Ø input at 8 kHz)	11.8 kW	100A (3Ø input at 8 kHz)	29.4 kW

Connector:	GV-L3/U3/U6/U12/H20:	GV-H40:
Drive terminals:	#8 (M4) screw terminals	#10 (M5) screw terminals
Mating terminals:	spade fork, 0.325" max. width	ring terminal, 0.25" I.D., 0.50" O.D.
Tightening torque:	20 in-lbs nom., 24 in-lbs max.	20 in-lbs nom., 24 in-lbs max.

Amplifier

Type:	GV-L3n:	40 kHz PWM;	3 phases
	GV-U3n:	8 kHz PWM;	3 phases
	GV-U6n/U12n/H20n/H40n:	8, 16, 20 kHz PWM;	3 phases

Performance

Accuracy: ±1 encoder count; encoder dependent

Environmental Specifications

		GV-L3n; GV-U3n/U6n/U12n; GV-H20n (with < 25W regen); GV-H40n	GV-H20n (with <100W regen)
Operating Temperature:	Still Air:	45°C (113°F)	35°C (95°F)
	Moving air:	50°C (122°F)	40°C (104°F)
	Minimum:	0°C (32°F)	0°C (32°F)
Storage Temperature:	-40°C – 85°C (-40°F – 185°F)		
Humidity:	0 – 95%, non-condensing		
Shock:	15g, 11msec half sine		
Vibration:	10 – 2000 Hz at 2g		

Standards

UL, cUL	508C	
CE for LVD	72/23/EEC	
	BS EN61010-1:1993/A2:1995 (ie includes 1995 amendment AMD 8961)	
	Safety requirements for electrical equipment for measurement, control, and laboratory use	Part 1. General requirements
CE for EMC	89/336/EEC	
	BS EN61800-3: 1997	Adjustable speed electric power drive systems Part 3. EMC product standard including specific test methods.
	IEC 61800-3: 1996	Adjustable speed electric power drive systems Part 3. EMC product standard including specific test methods.

Interface/Communication

Connector:	
Drive connector:	9 pin D-subminiature plug.
Mating connector:	9 pin D-subminiature receptacle
RS-232:	RS-485*:
Rx, Tx, Gnd	4-wire plus ground (Rx+, Rx-, Tx+, Tx-, Gnd)
9600 baud	9600 baud
8 data bits	8 data bits
1 stop bit	1 stop bit
no parity	no parity
full duplex	full duplex
	*twisted pair cabling recommended (e.g. Belden 9842)

Weight

Drive	Weight <i>pounds (kg)</i>
GV-L3n:	4.2 (1.9)
GV-U3n:	4.2 (1.9)
GV-U6n:	4.9 (2.2)
GV-U12n:	4.9 (2.2)
GV-H20n:	8.9 (4.0)
GV-H40n:	15.8 (7.2)

Inputs and Outputs

This section describes all inputs and outputs (I/O) located on the 50 pin DRIVE I/O connector. Not all are required for your system to operate. The next drawing summarizes which are required, and which are optional.

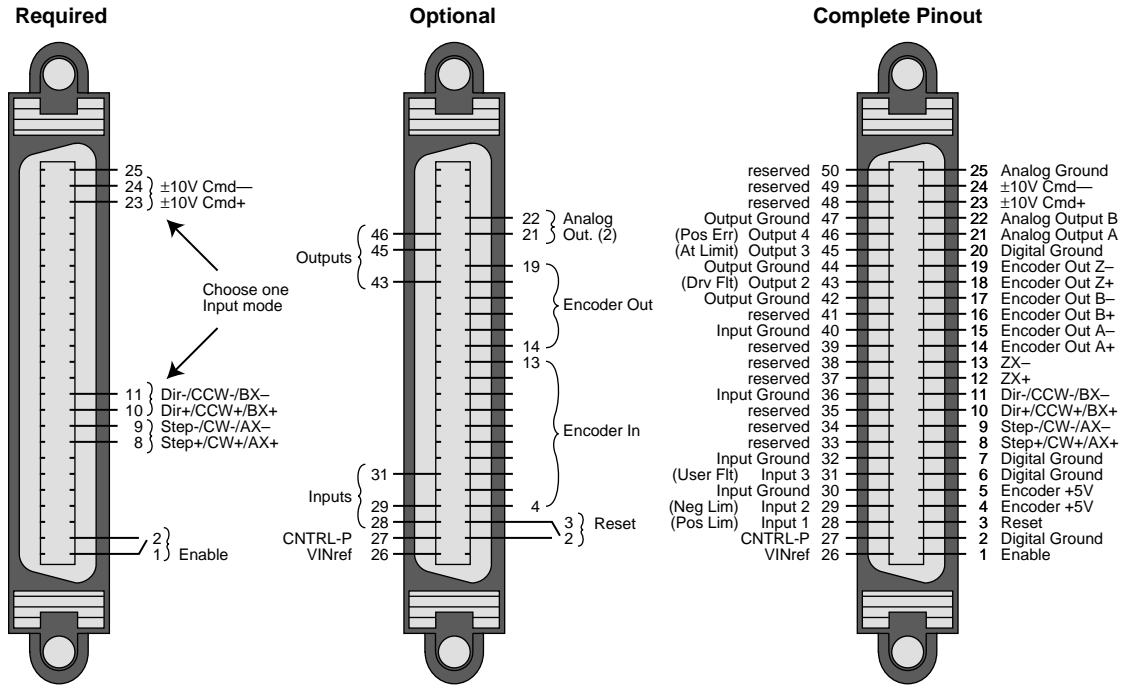

Drive I/O Connector

Connector Specifications:

	Gemini Drive:	Mating Connector* (not provided; see note):
Manufacturer:	AMP	AMP
Connector Type:	CHAMP .050 Series II	CHAMP .050 Series II
AMP Part Number:	2-178238-7	2-175677-7
Wire Gauge:	not applicable	use 28 AWG (0.08 mm ²)

* Note: Mating connectors are not provided with Gemini drives; Compumotor cables are available with mating connectors attached. If you make your own cables, you must use a "jack screw" style fastener, not "spring clip" style. The mating connector listed above is an insulation displacement connector (IDC), intended for use with molded cables.

Soldercup Connector

The soldercup connector and plastic screw lock backshell listed below will fit onto the Gemini's DRIVE I/O connector. Because the backshell is plastic, it should not be used in CE applications.

	Soldercup Connector	Screw Lock Backshell
Connector Type:	Soldercup Connector	Screw Lock Backshell
Manufacturer:	3M	3M
3M Part Number:	10150-3000VE	10350-52A0-008

Command Input (required)

The Gemini servo drive can accept several types of command input signals. Use the DMODE command to configure your drive to accept either $\pm 10V$ or a pulse input (step/direction, clockwise/counterclockwise, or encoder).

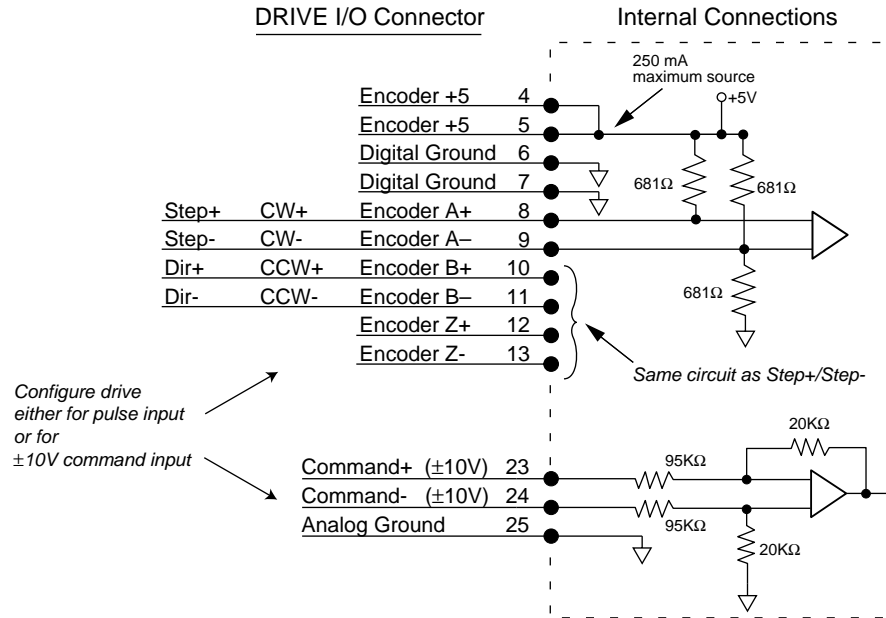

Command Inputs

If you use $\pm 10V$ command input signals, follow these instructions:

Connection Instructions for $\pm 10V$ Command Inputs

1. Connect COMMAND+ to pin 23.
2. Connect COMMAND- to pin 24.
3. Connect your controller's analog ground reference to pin 25.
4. If you use a Compumotor 6K Controller, use the analog command cable, not the step and direction command cable. See *Cable Specifications* later in this appendix for part numbers.

If you use a pulse source to generate step/direction, CW/CCW or encoder tracking signals, note that the drive's pulse inputs use differential receivers without opto-couplers. For best performance, follow these instructions:

Connection Instructions for Pulse Inputs

1. Connect your control's logic ground to the Gemini's ground, pin 6 or 7. This connection ensures that the signals stay within the common mode range of the differential receivers, and must not be omitted.
2. If you use a Compumotor 6K Controller, use the step and direction command cable, not the analog command cable. See *Cable Specifications* later in this appendix for part numbers.

Specifications for Pulse Inputs:

	Step Pulse:	Encoder:
Maximum Input Pulse Frequency:	2 MHz	2 MHz (pre-quadrature)
Minimum Input Pulse Width:	300 ns	300 ns

Enable Input (required)

To enable the drive and energize the motor, you must connect the enable input (pin 1) to digital ground (pin 2). The next drawing shows the internal circuit.

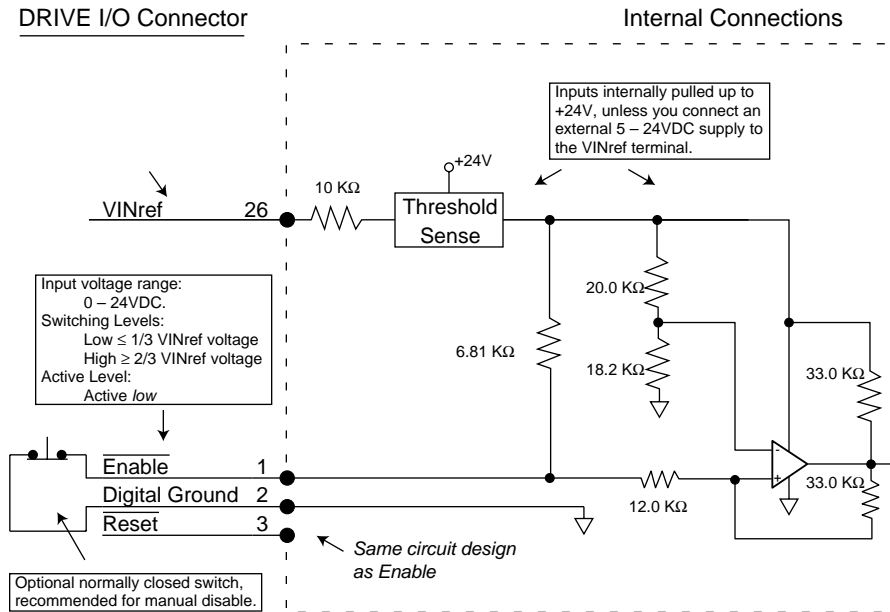

Enable Input and Reset Input

Reset Input (optional)

The reset and enable inputs use the same circuit design, as the drawing above indicates.

To reset the drive, temporarily connect the reset input (pin 3) to digital ground (pin 2). Reset begins when pin 3 is grounded. The drive will begin its power up sequence upon disconnection of pin 3 from ground.

VINref – Voltage Input Reference (optional)

Use VINref (pin 26) to set the input reference voltage for the enable, reset, and digital inputs.

It is not necessary for you to make connections to VINref. If you connect nothing, then the enable, reset, and inputs are internally pulled up to +24VDC. This is the factory default condition.

If you connect an external 5 – 24VDC power supply to VINref, then the input switching thresholds become:

$$\text{Low} \leq 1/3 * \text{VINref}$$

$$\text{High} \geq 2/3 * \text{VINref}$$

(Default:, with VINref at internal +24VDC: Low < 8V; High > 16V)

Digital Inputs (optional)

The Gemini drive has three digital inputs. Their functions are:

Input 1	Positive Limit Input
Input 2	Negative Limit Input
Input 3	User Fault Input

By default, these are +24VDC sourcing inputs. You can use VINref (pin 26) to change the switching voltage level. You can also use CNTRL-P (pin 27) to change the inputs from sourcing to sinking inputs. All connections are shown in the next drawing.

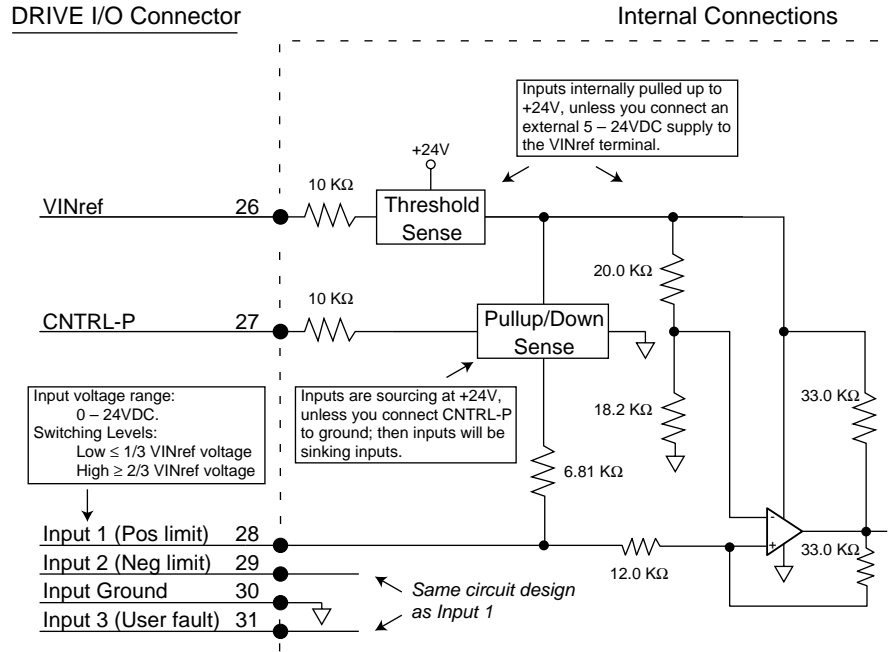

Inputs

You can use the INLVL and INDEB commands to configure the inputs as active high or active low, and to set the debounce time, respectively.

CNTRL-P – Reference for Digital Inputs (optional)

Use CNTRL-P (pin 27) to change the digital inputs from sourcing inputs to sinking inputs.

It is not necessary for you to make any connections to CNTRL-P. If you connect nothing, then the inputs are internally pulled up to VINref. If sourcing inputs are appropriate for your application, then make no connections to CNTRL-P.

If you connect CNTRL-P (pin 27) to digital ground (pin 30), then the inputs will become sinking inputs, and will sink current.

Digital Outputs (optional)

The Gemini drive has three digital outputs. Their functions are:

- Output 2* Drive Fault Output
- Output 3* At Limit
- Output 4* Position Error Output

* For compatibility with other Compumotor products, the outputs are numbered 2, 3 and 4, rather than 1, 2 and 3.

All connections are shown in the next drawing.

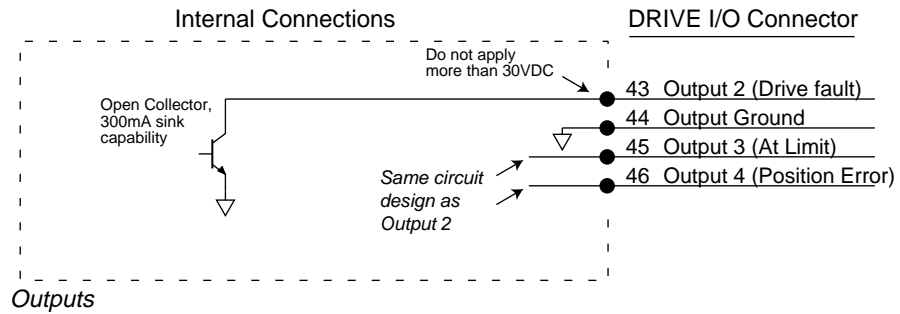

You can use the OUTLVL command to configure each of the outputs as active high or active low.

Encoder Output (optional)

Pins 14 – 19 are encoder outputs.

Encoder Output Specifications:

Default Resolution:	Quadrature outputs 4000 counts per revolution, post quadrature
Clockwise Rotation:	Channel A leads Channel B
Counterclockwise Rotation:	Channel B leads Channel A

The encoder outputs operate in one of two modes:

Pseudo Encoder Mode:

Output Channels A and B are derived from position information from the load feedback device (e.g. encoder or resolver). The outputs are *not* based on calculated or commanded position. Pseudo encoder mode is the default mode, unless all conditions listed in the next paragraph are satisfied. There is no Channel Z output in pseudo encoder mode.

Pass Through Encoder Mode:

When the following three conditions are satisfied, then Channels A, B, and Z are "passed through" the drive, from the feedback device (e.g. encoder or resolver) to the encoder outputs.

Required Conditions for Pass Through Encoder Mode

1. ERES and ORES values are equal.
2. Drive serial number is greater than 99072100143
3. Gemini Operating System version is 1.01 or greater.

If any one of these conditions is not satisfied, then the outputs will operate in pseudo encoder mode.

The encoder output circuit is shown in the next drawing.

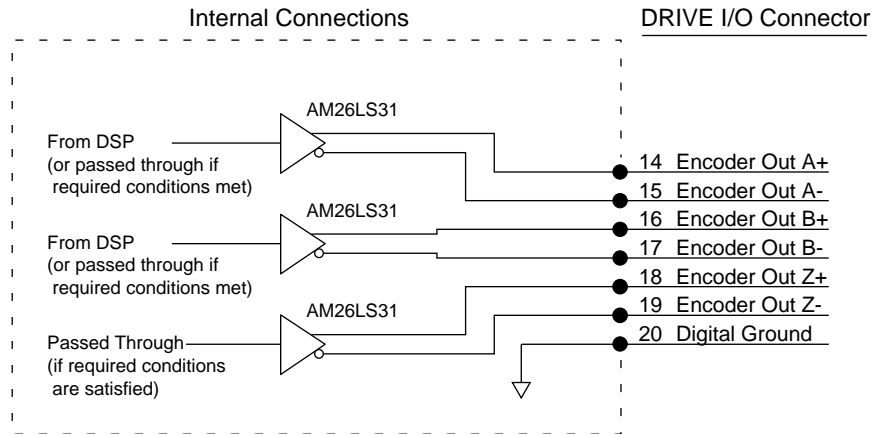

Encoder Outputs

You can use the ORES command to configure the encoder outputs.

Analog Monitor (optional)

Two analog monitor outputs are available on pins 21 and 22. Use pin 25 as a ground reference for these monitors.

Analog Monitor Specifications:

- Maximum Output: $\pm 10V$ (scalable)
- Resolution: 8 bits peak to peak (for full scale signal)

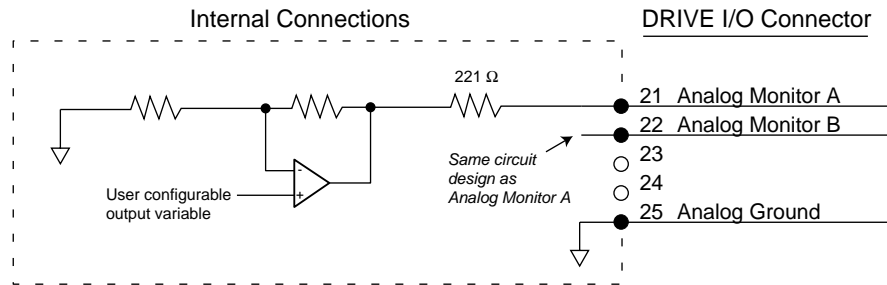

Analog Monitors

You can configure the analog outputs to monitor many different variables, such as current, velocity, temperature, etc. You can also scale the outputs. See the DMON commands in *Chapter 3 Configuration* and the *Gemini Programmer's Reference* for more information.



WARNING



Do not use Analog Monitors as control signals. Because of offsets, limited resolution and accuracy, use the analog monitor outputs only for oscilloscope monitoring.

Feedback Devices

This section describes inputs for encoder feedback, resolver feedback, motor thermal switch, and Hall effects located on the drive's 26 pin MOTOR FEEDBACK connector. The next drawing shows the pinout of the connector.

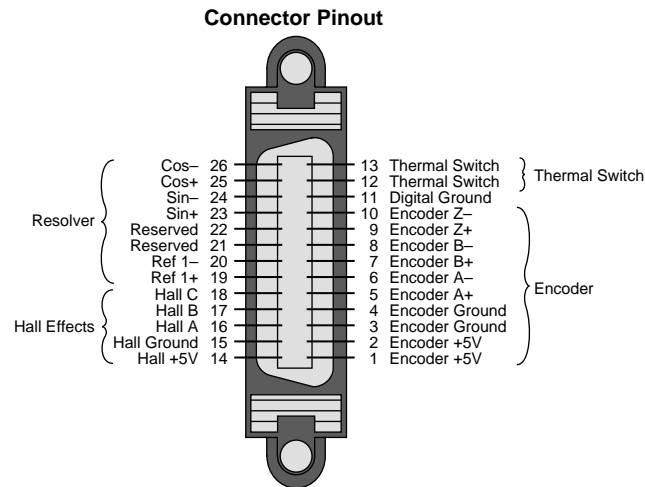

Motor Feedback Connector

Connector Specifications:

	Gemini Drive:	Mating Connector* (not provided; see note):
Manufacturer:	AMP	AMP-
Connector Model:	CHAMP .050 Series II	CHAMP .050 Series II
AMP Part Number:	2-178238-4	2-175677-4
Wire Gauge:	not applicable	use 28 AWG (0.08 mm ²)

* Note: Mating connectors are not provided with Gemini drives; Compumotor cables are available with mating connectors attached. If you make your own cables, you must use a "jack screw" style fastener, not "spring clip" style. The mating connector listed above is an insulation displacement connector (IDC), intended for use with molded cables.

Soldercup Connector

The soldercup connector and plastic screw lock backshell listed below will fit onto the Gemini's MOTOR FEEDBACK connector. Because the backshell is plastic, it should not be used in CE applications.

Connector Type:	Soldercup Connector	Screw Lock Backshell
Manufacturer:	3M	3M
3M Part Number:	10126-3000VE	10326-52A0-008

Encoder

If you use a motor with encoder feedback, connect your encoder to pins 1 – 10, as shown in the figure below.

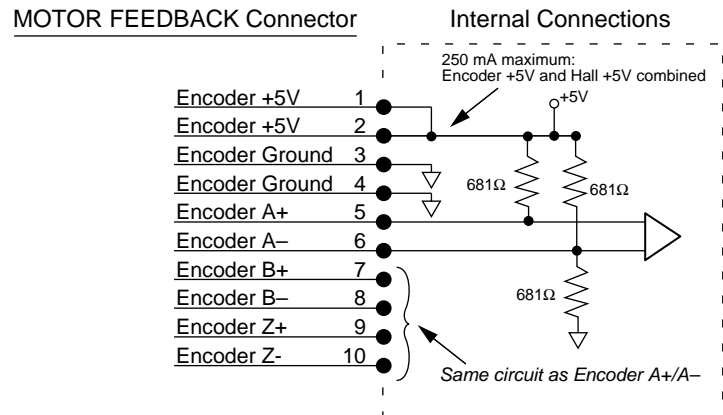

Encoder Input Connections

Because the wire used in many encoder cables is very thin, we provide two pins for encoder +5VDC (pins 1 and 2) and for encoder ground (pins 3 and 4). Connect two wires in your encoder cable to the +5VDC pins, and connect two wires to the encoder ground pins. We recommend that you splice each pair of wires to a larger diameter wire, as shown in the next drawing.

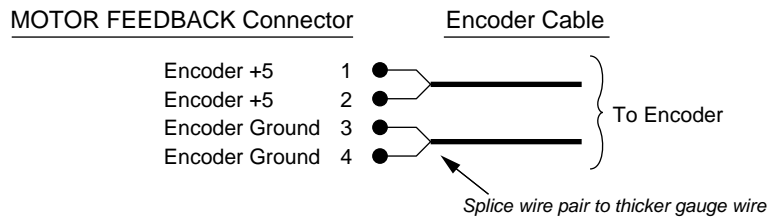

Splicing Wires Together

Splicing to a larger wire provides more wire for current conduction, minimizing voltage drop at the encoder. (Gemini motor feedback cables use this technique.)

Resolver

If you use a motor with resolver feedback, connect the resolver to pins 19 – 26, as shown in the figure below.

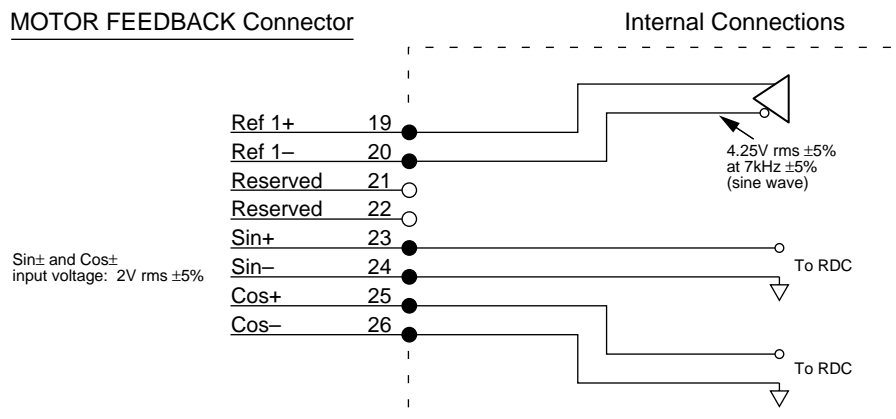

Resolver Input Connections

Motor Thermal Switch Connections (optional)

Connect your motor's thermal switch wires to pins 12 and 13 on the MOTOR FEEDBACK connector.

The drive checks for electrical continuity between pins 12 and 13. This continuity is usually provided by a normally-closed thermal switch mounted on the motor. If the motor overheats and the thermal switch opens, the loss of continuity triggers protection circuitry in the Gemini drive. The drive will turn off power output to the motor, illuminate the left LED red, and set the motor fault and drive fault bits. You can monitor the fault bits with the TAS and TASX commands.

To resume operations after the motor cools and its thermal switch closes, cycle power or issue a DRIVE1 command.

If your motor does not have a thermal switch, short pins 12 and 13 together. The drive will experience a motor fault if neither a thermal switch nor a jumper wire is attached to pins 12 and 13.

Hall Effects

Connect your motor's Hall effect wires to pins 14 – 18 on the MOTOR FEEDBACK connector.

The Gemini GV drive is designed to be used with motors that have single-ended, open collector Hall outputs. Internally, the drive pulls these signals up to +5V. The Hall effect circuit is shown below.

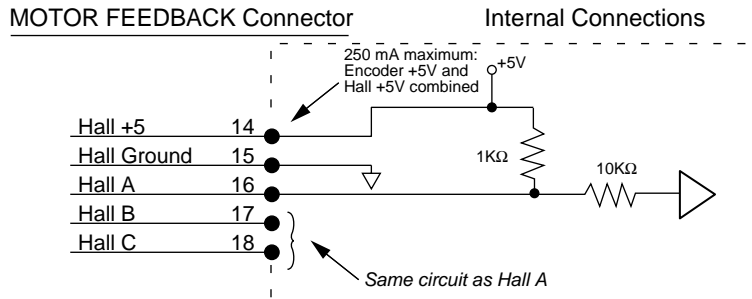

Hall Effect Connections

The Gemini drive uses the Hall effect inputs to synchronize the encoder with the motor's internal magnets at the start of motion. Initial commutation is trapezoidal; once the drive establishes synchronization it changes to sinusoidal commutation based on encoder position.

Dimensions

Drive Dimensions

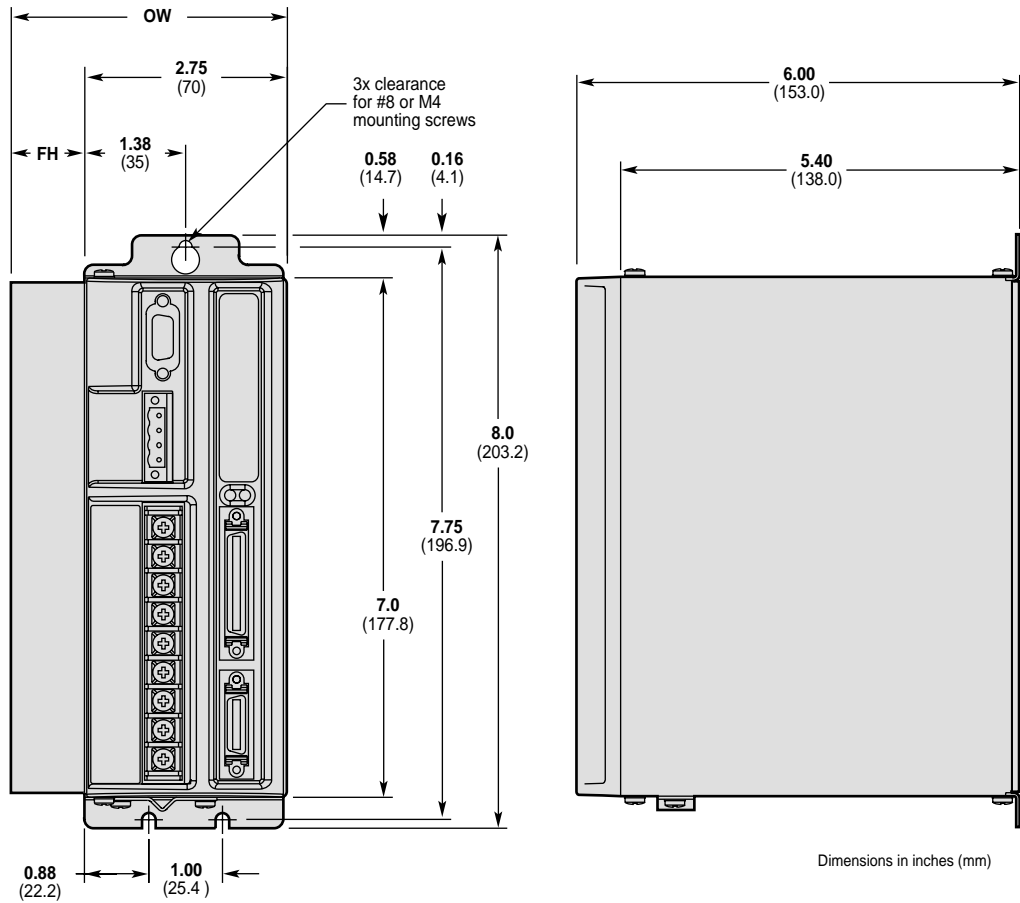

Product	OW Overall Width inches (mm)	FH Fin Height inches (mm)
GV-L3n	3.13 (79.4)	0.38 (9.5)
GV-U3n	3.13 (79.4)	0.38 (9.5)
GV-U6n	3.75 (95.3)	1.00 (25.4)
GV-U12n	3.75 (95.3)	1.00 (25.4)

Dimensions (Shorter Enclosure)

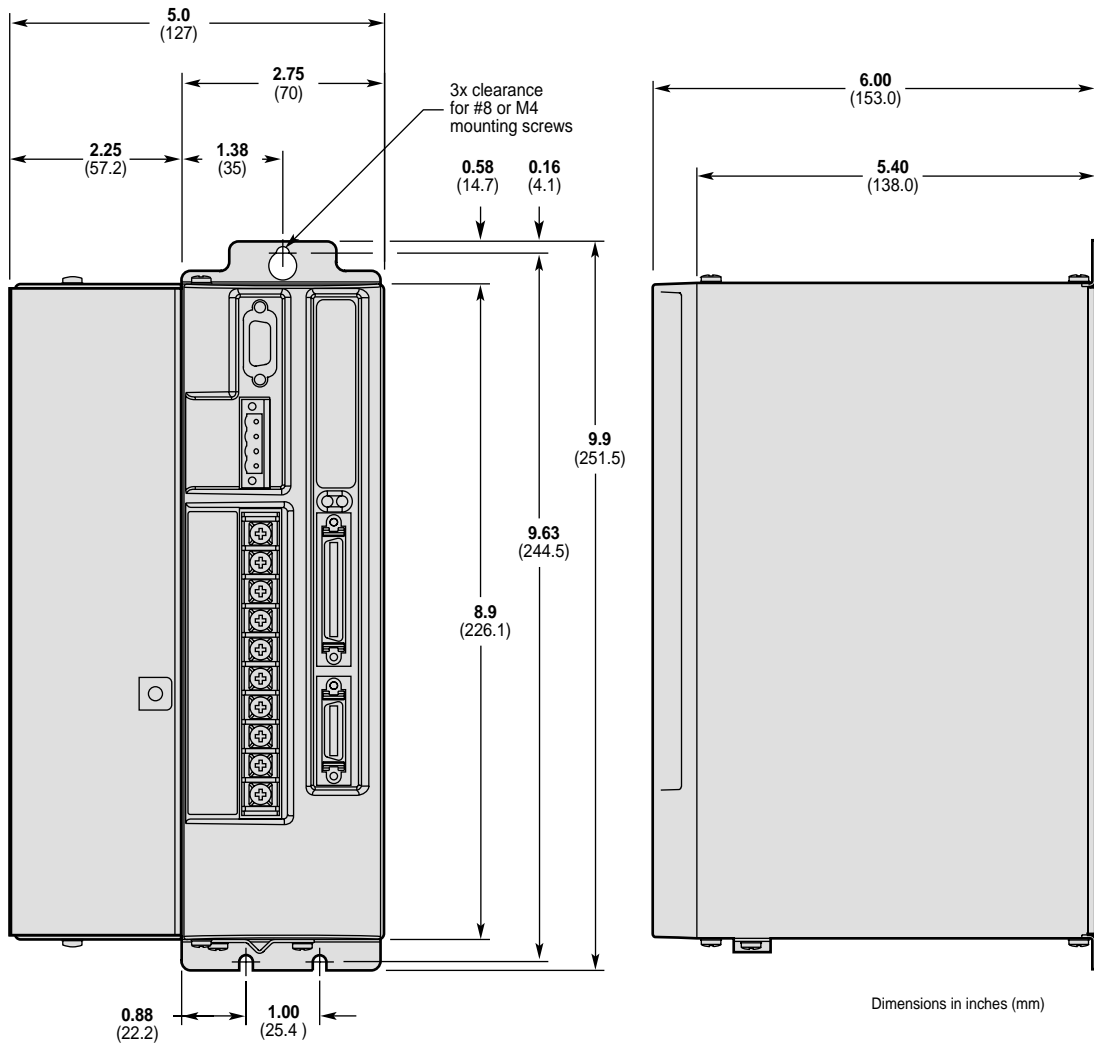

Dimensions – GV-H20n

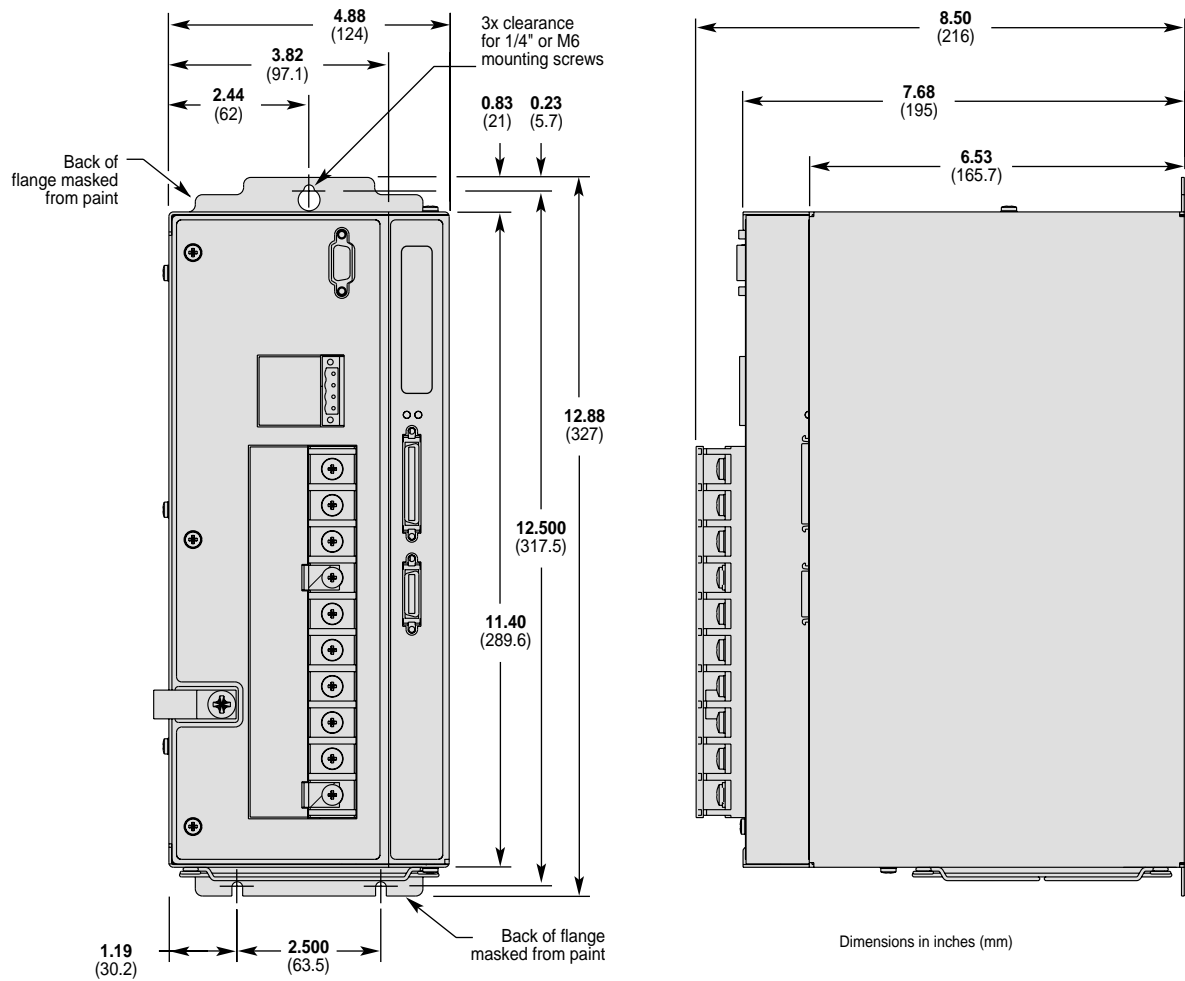

Dimensions – GV-H40n

Drive Mounting

The Gemini drive is a vented product. Mount it under an overhang to prevent material spilling into the drive.

Panel Layout Dimensions

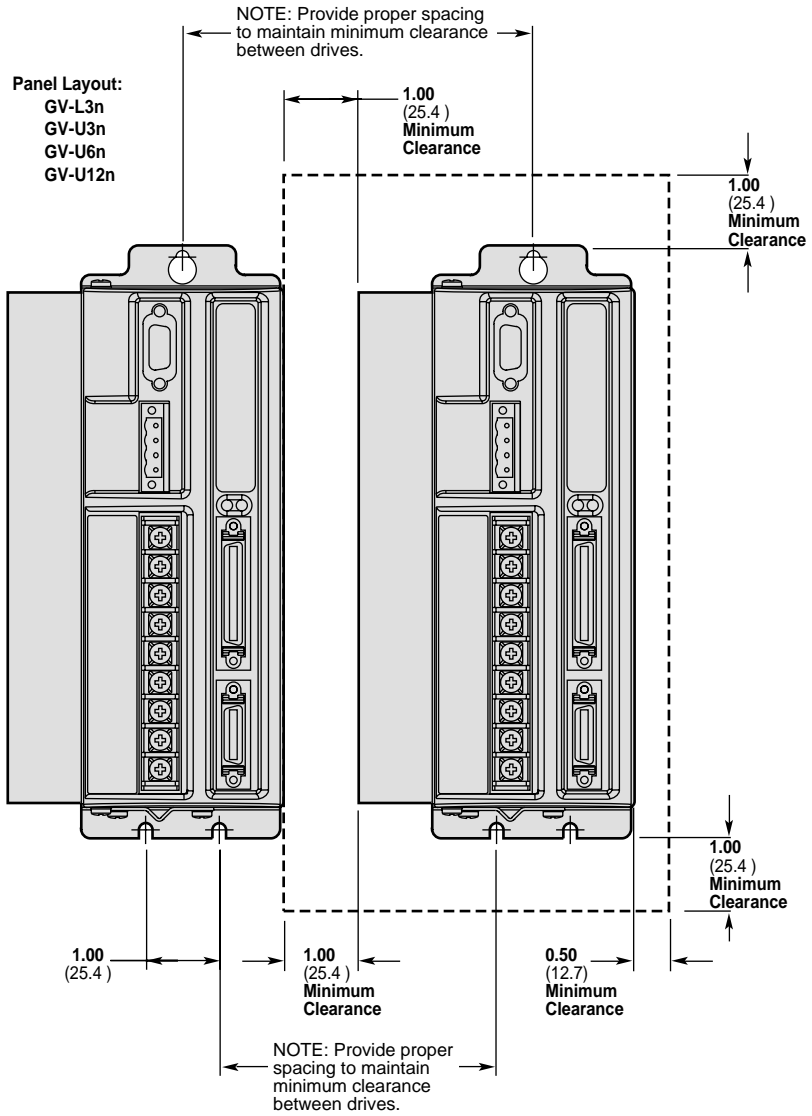

Panel Layout Dimensions – GV-L3n, GV-U3n/6n/12n

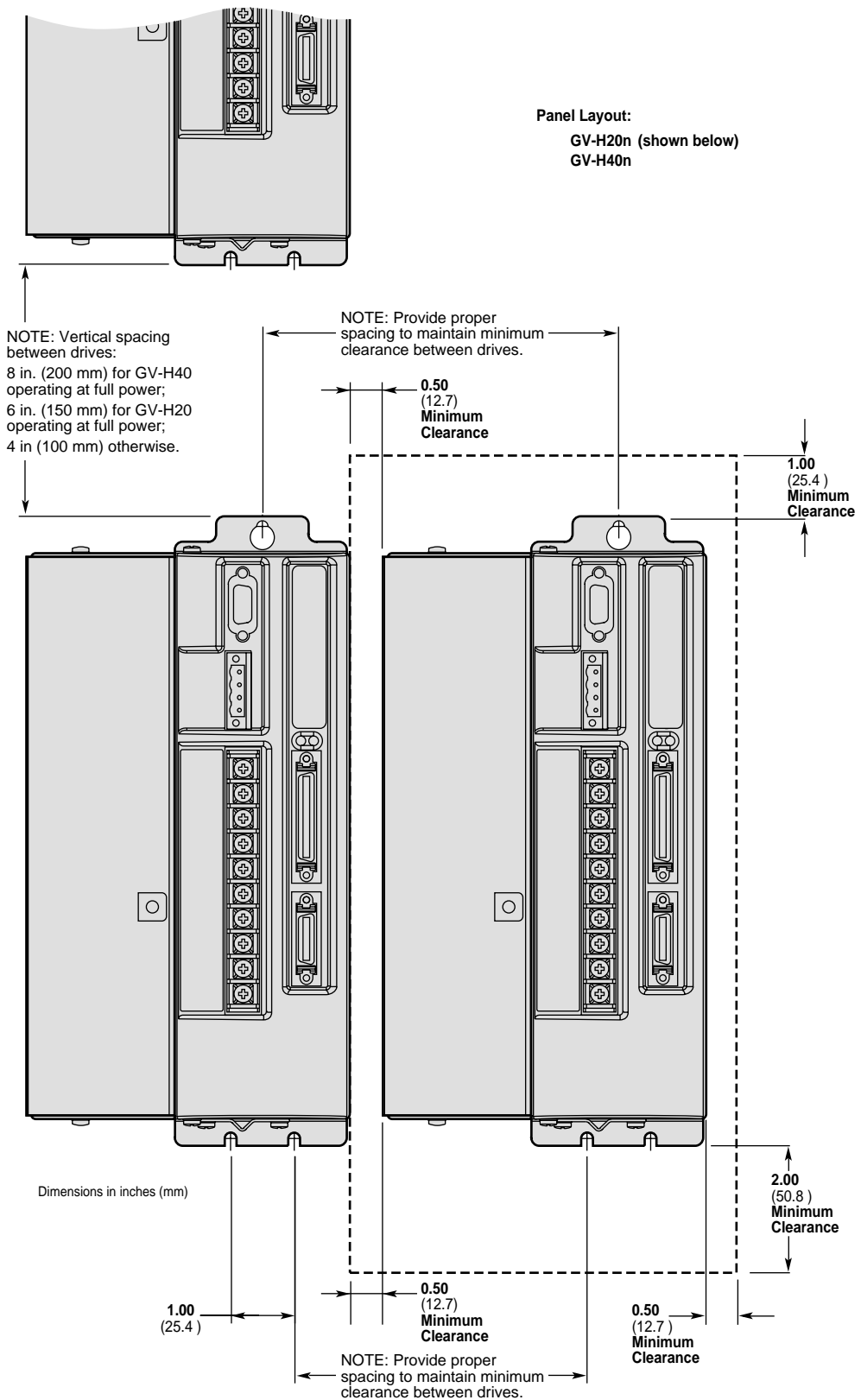

Panel Layout Dimensions – GV-H20n and GV6-H40n

Protective Circuits

Short Circuit Protection

The Gemini drive has an internal circuit that protects it from short circuits between one motor terminal to another (phase to phase), or from any motor terminal to earth. A short circuit fault is a latched fault.

Short circuit fault caused by:	Phase to phase short circuit Phase to earth short circuit
Results of Fault:	Power to motor is turned OFF LEDs: Left = illuminated RED; Right = off Fault output is activated Latched fault

Inrush Current Protection

The Gemini drive has internal circuitry that protects it from high inrush current when power is initially applied to the drive. The circuitry works automatically.

Drive	Inrush Current Limiter (ohms):	Current limiter bypassed with shorting relay:
GV-L3n	5Ω	yes
GV-U3n	10Ω	yes
GV-U6n	10Ω	yes
GV-U12n	10Ω	yes
GV-H20n	10Ω	yes
GV-H40n	20Ω	yes

The shorting relay removes the inrush current limiter after drive startup. This allows maximum bus voltage during high acceleration/peak torque/maximum speed applications.

Inrush current is temperature dependent:

Ambient Temperature:	Inrush Current Limit:
25°C (77°F)	less than 35 amps
50°C (122°F)	less than 70 amps

Drive Overtemperature Protection

The Gemini drive's overtemperature circuit monitors the drive's internal temperature sensors. If the sensors exceed the threshold temperature, the drive issues an overtemperature fault.

Threshold Temperature:	All drives except GV-H20n: 80°C (176°F) GV-H20n: 90°C (194°F)
Results of Fault:	Power to motor is turned OFF LEDs: Left = illuminated RED; Right = off Fault output is activated Latched fault

Motor Overtemperature Protection

The Gemini drive has two motor overtemperature circuits:

Hardware Switch:	a thermal switch is embedded in Compumotor motor windings
P_t Thermal Model:	the drive's internal operating software predicts motor winding temperature, based on motor parameters.

Undervoltage Protection

The Gemini drive's undervoltage protection circuit monitors AC input voltage. If the voltage falls below 75VAC while the drive is operating (85VAC for GV-H20), the drive issues an undervoltage fault and turns off power to the motor.

Undervoltage protection has the following features:

Threshold Voltage:	Voltage falling below 75VAC trips fault (85VAC for GV-H20n)
Results of Fault:	Power to motor is turned OFF LEDs: Left = illuminated RED; Right = off Fault output is activated Latched fault

Overvoltage Protection

The Gemini drive's overvoltage circuit protects the drive from excessive regeneration. If the voltage on the motor output terminals rises above the threshold voltage, the drive disables its output terminals, and the motor will freewheel.

Threshold Voltage:	GV-L3n: 212VDC GV-U3n/6n/12n/H20n/H40n: 410VDC
Results of Fault:	Power to motor is turned OFF LEDs: Left = illuminated RED; Right = off Fault output is activated Latched fault



CAUTION



Overvoltage protection monitors only the motor output terminals (DC motor bus). It does not protect against an overvoltage on the AC input terminals.

Current Foldback

The GV drive's current foldback circuit helps to protect the motor from damage due to prolonged high currents.

If your drive is operating above its continuous rating, use the figure below to predict the number of seconds until foldback will occur. For example, the figure shows that at the drive's peak current rating (250% of continuous), foldback will occur after six seconds.

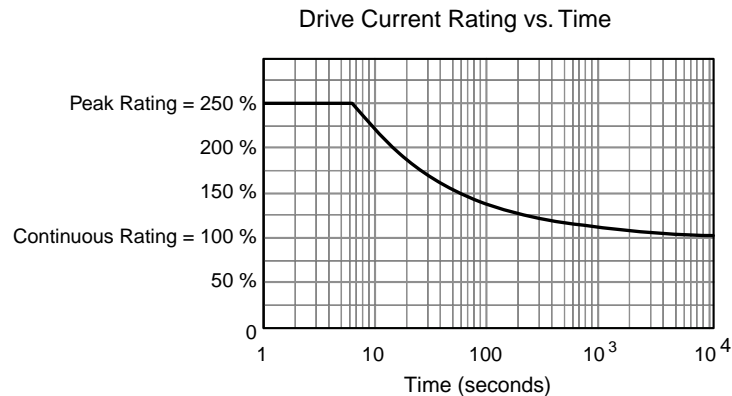

Time Until Foldback

See *Chapter 3 Configuration* for more information on how to configure the current foldback circuit to protect your motor.

Cable Specifications

This section contains specifications for Compumotor cables and cabling accessories you can use with Gemini drives.

CE Cables

Many Compumotor cables are *CE Cables*. If installed according to instructions in *Appendix C – Regulatory Compliance: UL and CE*, these cables are designed to aid the user in gaining European Compliance, and are thus an integral part of a CE system solution. CE cables add RF screening and bonding to reduce emissions, and provide high integrity safety Earth bonding. They also help to reduce problems in high electrical noise environments.

Non-CE Cables

Compumotor also offers non-CE cables, for applications where CE compliance is not required, and where ambient electrical noise does not cause problems. Because these cables are either unshielded, or contain simple foil shielding terminated by a drain wire, they do not provide significant shielding of electrical noise at high frequencies.

To help you select the correct cables for your application, see Compumotor’s Technical Bulletin *TB269: Proper Cable Selection – CE vs. Non-CE Gemini Applications*.

Analog Command Cable

If you operate the drive in torque or velocity mode, use this cable to connect the Gemini GV drive to a Compumotor 6K controller.

NOTE: If you use the Gemini GV drive in step and direction mode, use the step and direction command cable.

CE Cable:	Part Number 71-016987-10	10 ft. (3 m) in length
Non-CE Cable:	Part Number 71-019863-04	4 ft. (1.2 m) in length

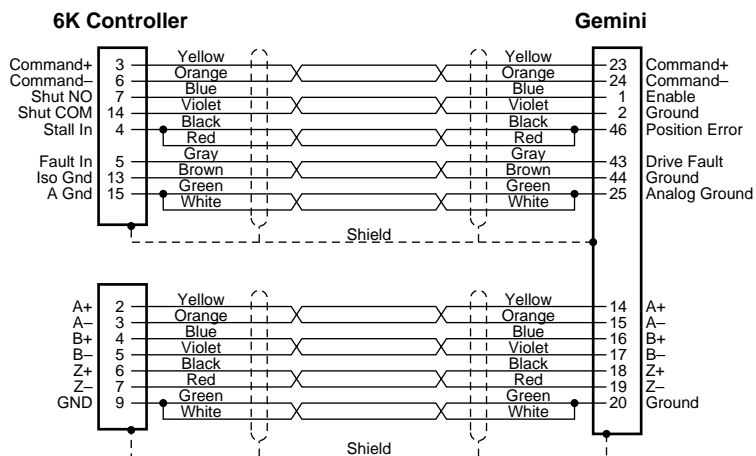

Cable – Analog Command (color code is for CE Cable)

Step and Direction Command Cable

If you operate the drive in step and direction (position) mode, use this cable to connect the Gemini drive to a Compumotor 6K controller

CE Cable: Part Number 71-016966-10 10 ft. (3 m) in length
 Non-CE Cable: Part Number 71-019862-04 4 ft. (1.2 m) in length

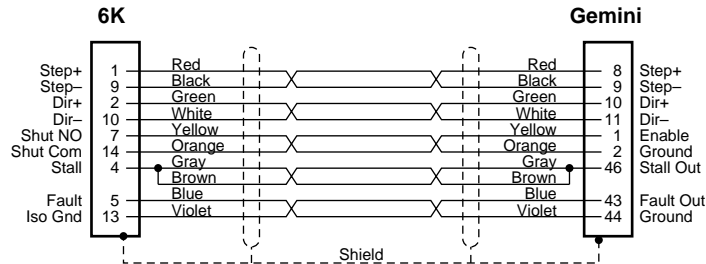

Cable – Step and Direction (color code is for CE Cable)

Gemini 50 Pin Connector to Flying Leads Cable

Use this cable to connect the Gemini drive's 50 pin connector to a Compumotor 6200, AT6n00, 6250, AT6n50 or non-Compumotor indexers/controllers.

NOTE: If using Compumotor 6000 Series *stepper* products, connect Gemini VINref (pin 26) to +5VDC, such as Gemini ENCODER +5 (pin 4 or 5). Do not connect Gemini VINref to any voltage higher than +5VDC. (This VINref connection is not necessary on 6000 Series *servo* products.)

CE Cable: Part Number 71-016943-10 10 ft. (3 m) in length
 Non-CE Cable: Part Number 71-019861-04 4 ft. (1.2 m) in length; and
 71-019861-10 10 ft. (3 m) in length

Compumotor 6200, AT6n00 Connections

The next drawing shows connections to a Compumotor 6200 or AT6n00 indexer.

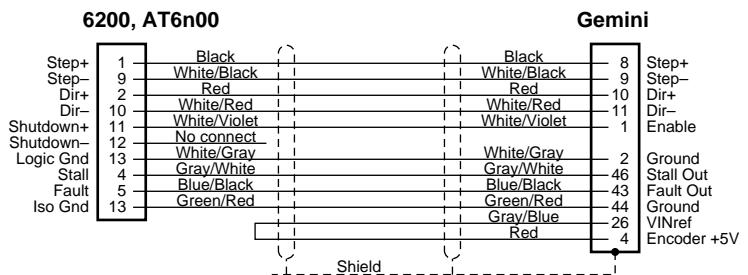

Cable – Flying Leads – 6200 Connections (color code is for CE Cable)

Compumotor 6250, AT6n50 Connections

The next drawing shows connections to a Compumotor 6250 or AT6n50 controller.

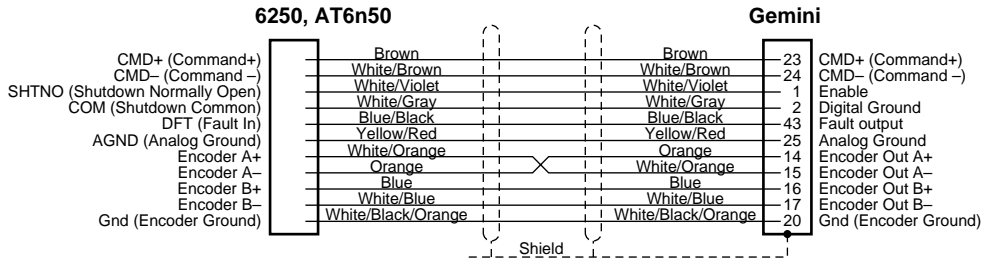

Cable – Flying Leads – 6250 Connections (color code is for CE Cable)

Flying Lead Cable – Color Code

The next drawing shows the color code for the 50 pin connector/flying lead cable. Note that the CE and non-CE cables have different color codes.

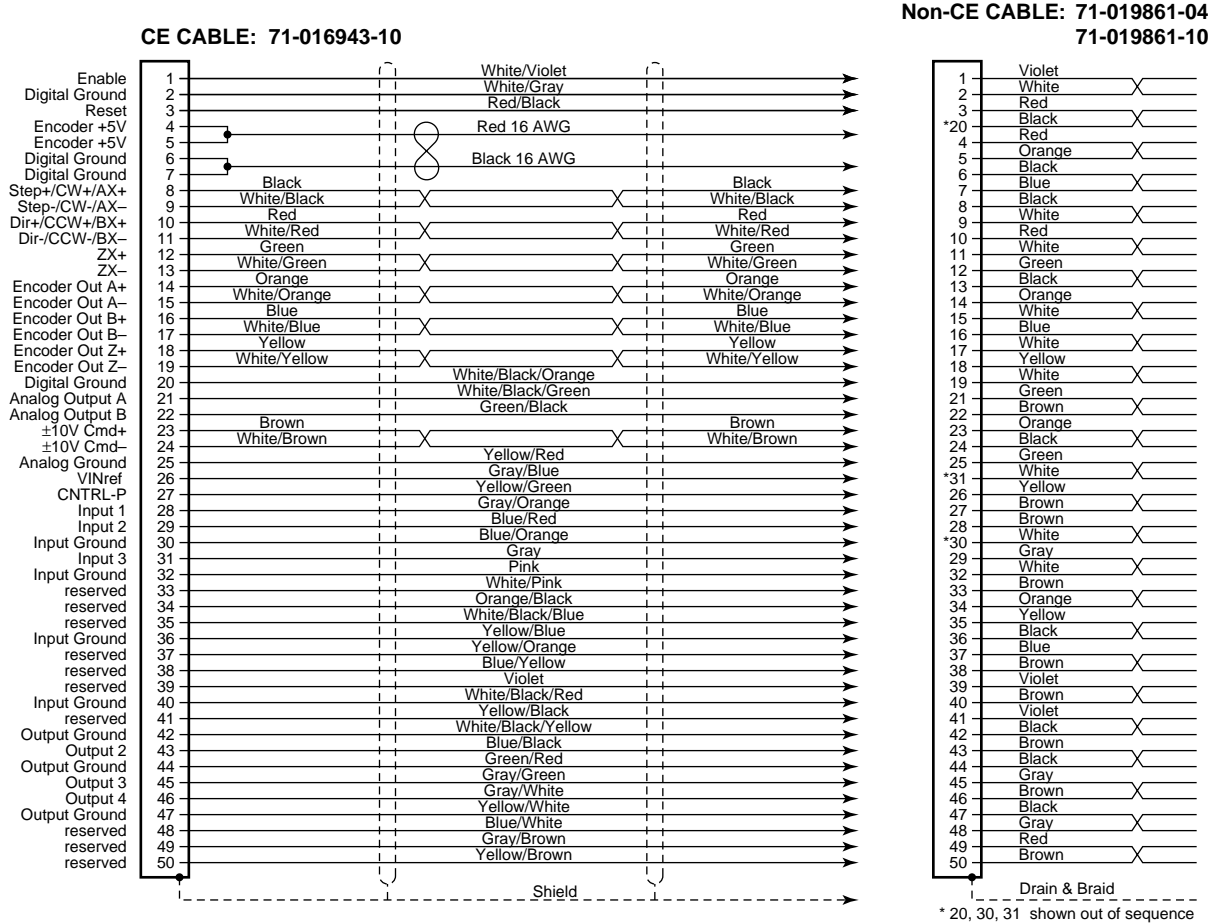

Cable – Flying Leads (color code for CE and non-CE cables)

Gemini 50 Pin Connector to 50 Pin D-Connector Cable

Use this cable to connect the Gemini drive's 50 pin DRIVE I/O connector to the 50 pin D-connector on the Gemini 50 pin breakout module (GEM-VM50).

CE Cable: Part Number 71-016945-03

This cable has the same pinout and color code as the CE version of the flying lead cable; instead of flying leads, it has a 50 pin D-connector on the end.

Gemini GEM-VM50 – 50 Pin Breakout Module

Use the 50 pin breakout module for access to individual terminals on the 50 pin connector. The GEM-VM50 includes the cable above.

Description:	Part Number:
50 pin Breakout Module (with Cable)	GEM-VM50
50 pin Breakout Module (without cable)	01-016986-01

Null Modem Cable – 9 Pin D-Connector to 9 Pin D-Connector

Use this cable for RS-232 communications between the Gemini drive and a terminal. Note that this is not a "straight-through" cable; pins 2 and 3 are crossed, making it a "null-modem" cable.

CE Cable: Part Number 71-016939-10

Connector: 9 pin female D-subminiature connector on each end

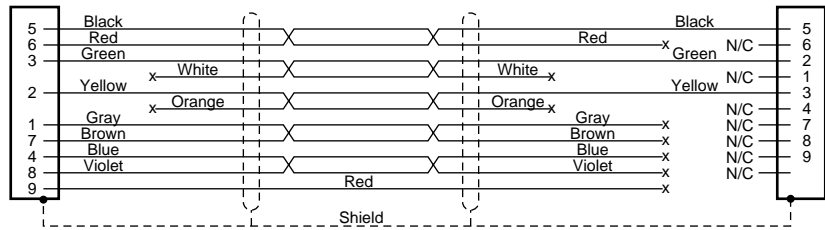

Cable – RS-232 Null Modem

Gemini GC-26 and GC-50 Connectors

Two breakout modules are available that connect directly to the Gemini's MOTOR FEEDBACK and DRIVE I/O connectors.

NOTE: These modules are recommended for system prototyping only—not for permanent installation.

Description:	Part Number:
26 pin Connector/Breakout Module	GC-26
50 pin Connector/Breakout Module	GC-50

Dimensions are shown below.

CAUTION

Connect wires to the GC-26 and GC-50 *before* installing in the drive. This will avoid damage that may be caused by wiring the connector while attached to the drive.

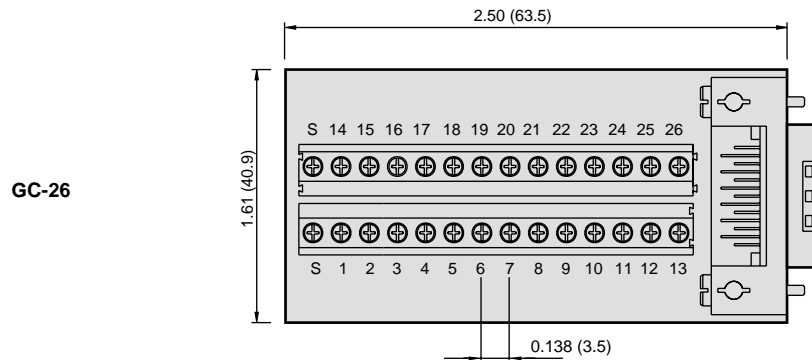
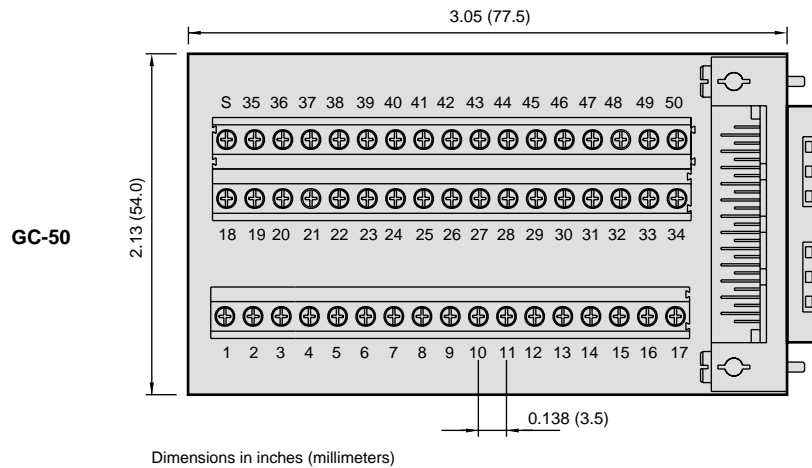

GC-26 and GC-50 Dimensions

Gemini 26 Pin Feedback Connector Kit

A cable connector backshell kit is available from Compumotor. The kit includes plug, cover, and all parts necessary to assemble the connector. It also includes spade lugs to install on the motor cable. The part number is:

GFB-KIT

The plug mates with the drive's 26 pin MOTOR FEEDBACK connector.

APPENDIX B

Using Non-Compumotor Motors

IN THIS CHAPTER

- Commands for Motor Configuration
 - Motor Requirements
-

Using Non-Compumotor Motors

If you use a non-Compumotor motor, you must configure the drive for your motor by setting values for all commands in the following table. Also see the *Motor Parameters* table on the *Motion Planner CD-ROM* for examples of recommended drive configuration settings for Compumotor motors.

Commands for Motor Configuration

Command:	Description:
ERES	encoder feedback resolution; counts per revolution, post-quadrature
DMTIC	continuous current; amps – rms, 40°C (104°F)
DMTICD	continuous current derating; percent
DMTKE	voltage constant; V/krpm
DMTRES	line-to-line resistance; at 25°C (77°F)
DMTJ	rotor inertia; kg-m ² *10 ⁻⁶
DPOLE	number of pole pairs
DMTW	rated speed; revolutions per second
DMTIP	peak current; amps rms
DMTLMN	minimum line-to-line inductance; mH
DMTLMX	maximum line-to-line inductance; mH
DMTD	motor damping; nM/rad/sec
DMTRWC	winding to case thermal resistance; °C/watt
DMTTTCM	motor case thermal time constant; minutes
DMTTTCW	motor winding thermal time constant; minutes
DPWM	PWM switching frequency
DMTMAX	motor maximum temperature

Use Motion Planner or Pocket Motion Planner to enter these command settings into the drive's memory. See the *Gemini Programmer's Reference* for more information on commands.

Motor Requirements

If you have questions about using a non-Compumotor motor with a Gemini drive, call Technical Support (see phone numbers on the inside cover of this manual).

Hall Sensor Configuration/Troubleshooting

This section will assist you in resolving a Hall fault (TASX Bit 21). Several problems can cause a Hall fault. The following list will help identify these problems.

Troubleshooting Checklist:

1. Does THALL report back either 0 or 7?
IF YES: see Problem #1 or #2, below.
2. Does THALL change if you move the motor by hand?
IF NOT: see Problem #2, below.
3. Does THALL have six distinct Hall states from 1 to 6? (No numerical order is necessary.)
IF NOT: see Problem #2, below.
4. As reported by THALL, are there n times 6 Hall states as the rotor turns one revolution, where n is equal to the number of pole-pairs. (Linear motors: $n = \text{pitch}$)
IF NOT: see Problem #2 or #3, below.

5. As reported by THALL, is the Hall state sequence [1, 5, 4, 6, 2, 3, 1 ...] as the motor turns clockwise? (Clockwise means TPE is increasing; it is also the direction the motor turns in DMODE13.)
IF NOT: see Problem #4, below.
6. Does TASX report a Hall fault each time the drive is enabled (DRIVE1), even though the Hall state sequence is correct?
IF YES: see Problem #4, below.
7. Is the Hall fault intermittent? (Intermittent means the fault does not occur every revolution.)
IF YES: see Problem #5, below.



Possible Problems:

- #1: No Hall states are seen by the drive.
- #2: Cable is not connected, or is connected incorrectly (miswired).
- #3: DPOLE or DMEPIT is not set correctly.
- #4: Either the motor wires or the Hall wires are connected incorrectly.
 - Use Procedure I to fix this problem by changing the motor wires.
 - Use Procedure II to fix this problem by changing the Hall wires.
- #5: The Hall wires or the encoder wires may have loose connections, causing intermittent faults.

Procedure I:

Use this procedure to connect your **motor wires** to the GV drive.

1. Randomly connect two motor wires and slowly apply a positive voltage with respect to the third. See the next drawing.

WARNING

This procedure could damage the motor. Slowly increase the voltage until the motor moves. Do not exceed the rated current.

2. If THALL reports back a 1, 2 or 4, change SHALL from either 0 to 1 or from 1 to 0. After you change SHALL, reset the drive.
3. Repeat step 1 until THALL reports a value of 6.
4. The wire which is on the negative voltage or ground is motor wire W. The two wires at the positive voltage are U and V.
5. Now there are two possibilities:
 - 5.1. Connect the motor wires to the terminals. Operate the drive in DMODE13. If the motor does not turn in the clockwise direction, exchange motor wires U and V.
 - 5.2. Put positive voltage on motor wire W together with either U or V and put negative voltage or ground on the remaining wire. If THALL reports a value of 3, the wire at the negative voltage is V. If THALL reports a value of 5, the wire at the negative voltage is U.

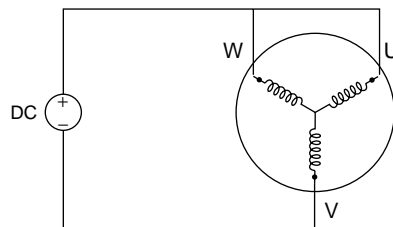

Connection Diagram

Procedure II:

Use this procedure to connect your **Hall wires** to the GV drive.

1. First operate the drive in DMODE13 and verify that the motor turns clockwise. If not, swap any two motor wires.

- Connect motor wires U and V and slowly apply a positive voltage with respect to W. See the previous drawing.

⚠ WARNING ⚠

This procedure could damage the motor. Slowly increase the voltage until the motor moves. Do not exceed the rated current.

- If THALL reports a value of 1, 2 or 4, change SHALL from either 0 to 1 or from 1 to 0. After you change SHALL, reset the drive.
- Change the Hall wires until THALL reports a value of 6.
- Connect motor wires U and W and slowly apply a positive voltage with respect to V.
- If THALL does not report a value of 3, change Hall wires B and C.
If THALL reports a value of 3, the wires are connected correctly.

The following table summarizes phase voltages and their corresponding Hall states. Starting with SHALL0 and the phase voltages as shown, the THALL command should report the Hall states that match the “Correct” column. If instead THALL reports Hall states that match the “Use SHALL1” column, enter SHALL1 and reset the drive. The Hall states should now match the “Correct” column.

Phase			Hall State	
U	V	W	Correct	Use SHALL1
-	-	+	1	6
-	+	+	5	2
-	+	-	4	3
+	+	-	6	1
+	-	-	2	5
+	-	+	3	4

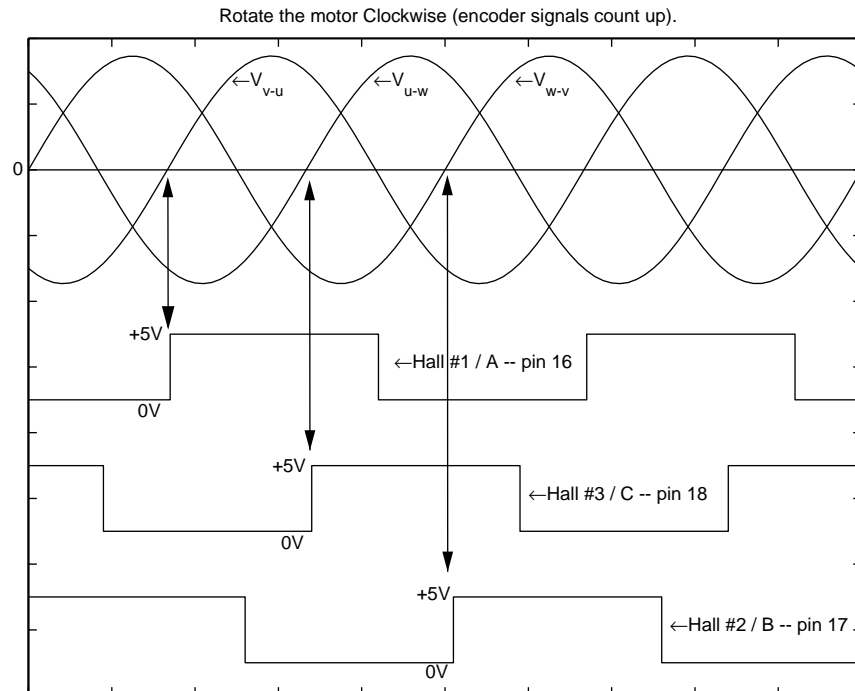

Motor Terminal Voltages (back EMF) and Hall Sensor Signals

APPENDIX C

Regulatory Compliance: UL and CE

IN THIS CHAPTER

- Installation Instructions
 - Installation Guidelines
 - System Installation Techniques
-

Regulatory Agencies

The Gemini family of products is designed to meet the requirements of global regulatory agencies.

Gemini products have shown compliance with the regulatory agencies in the following list. The list also shows additional steps users must take to ensure compliance.

Agency	Additional Steps User Must Take
UL, cUL	Mains fuses
CE (LVD)	Mains fuses; earth connection for drive and motor (if applicable), proper installation
CE (EMC)	Varistors, mains filter, EMC cabling, EMC ready motor, proper installation

Installation Instructions

Although Gemini drives are technically considered motion control components and are therefore not within the scope of the European union's CE (Conformité Européenne) directives, Compumotor has taken the initiative to provide its customers with easy to integrate motion control products that meet global requirements.

The following constitutes what is typically required to install Gemini drives into a CE compliant system. Additional installation measures may be required at some locations. The machine builder has ultimate responsibility for machine compliance.

Low Voltage Directive (LVD) Installation Requirements:

- Mains fuses
- Drive safety earth conductor
- Motor safety earth (for motor voltages greater than 75 volts)
- Drive must be installed such that the hazardous live terminals (barrier strip) are not accessible under normal operation

Electromagnetic Compatibility (EMC) Installation Requirements:

- Product does not need to be placed within an enclosure
- Mains filter (see filter recommendations)
- Transient suppressors (mains surge test)
- Compumotor EMC cabling (requires no special cable preparation)
- EMC ready motor, or motor with EMC installation information
- Additional installation hardware as shown in drawings in this appendix

Additional Steps to Ensure Compliance

To meet the requirements of regulatory agencies, you *must* follow the installation guidelines presented below.

Mains Fuses

Instructions for installing mains fuses were presented in *Connecting AC Power in Chapter 2 Installation*.

EMC – Electromagnetic Compatibility Directive – 89/336/EEC

In order to meet the requirements of the Electromagnetic Compatibility Directive 89/336/EEC, the entire system must comply: motor, drive, cabling, and peripherals. The installation of the product must include the following items.

EMC Cabling

For electromagnetic compatibility, you must use Parker Compumotor CE cables.

EMC Motor

For system CE compliance, you must use an EMC-ready motor, or a motor that has demonstrated acceptable EMC performance.

NOTE: Motors may bear the CE mark. This mark indicates the motor meets the requirements of construction and safety—*not EMC compliance*.

Motors with shielded cabling or pipe thread style cabling options allow the easiest integration into machines required to bear the CE mark for EMC.

Varistors

You must install varistors or other voltage surge limiting devices in order to meet the requirements of EN61000-4-5. Place a Littelfuse V275LA2Ø or equivalent varistor from line to line, and from lines to earth before the mains filter, as shown in the *EMC Installation* drawings later in this appendix. (Intersil, General Electric and Littelfuse manufacture equivalent varistors.)

Mains Filter

You must install a mains filter. The next table lists recommended filters.

Filter:	Continuous Current (amps)	GV-L3 GV-U3	GV-U6	GV-U12	GV-H20	GV-H40
3EP1 ¹	3	X				
6EP1 ¹	9	X	X			
10EP1 ^{1,3}	10	X	X			
FN2070-10-06 ²	10	X	X	X		
FN2070-12-06 ²	12	X	X	X		
FN2070-16-06 ^{2,3}	16	X	X	X		
16FCD10 ¹	16				X	
FN351-16/29 ²	16				X	
FN351-25/29 ²	25					X
25FCD10 ¹	25					X
36FCD10 ¹	36					X
FN351-36/29 ²	36					X

Product with applicable mains filter denoted by "X"

¹ Corcom; ² Schaffner;

³ Available from Compumotor: 10 amp filter – part number 47-016140-01
16 amp filter – part number 47-017900-01

+24VDC Power Supply

If you use the +24VDC power supply Parker Compumotor offers for sale (PS-60W), no additional filter is required on the +24VDC mains. If you use another manufacturer's +24VDC power supply, it should be CE marked for safety and electromagnetic compatibility.

Installation Guidelines

Gemini products are made available under “Restricted Distribution” for use in the “Second Environment” as described in EN 61800-3: 1996, page 9.

Cabinet Mounting

For Electromagnetic Compatibility, cabinet mounting is not required. However, Gemini drives have high voltage terminals—for safety purposes, the drive must not be user accessible during normal operation.

Drive Mounting

The Gemini drive is designed to be mounted to an earthed metal panel. For EMC performance, mount the mains filter to the same panel, as close to the drive as possible. See the *EMC Installation* drawing at the end of this appendix.

Cable Routing

Route high power cables (motor and mains) at right angles to low power cables (communications and inputs/outputs). Never route high and low power cables parallel to each other.

Cable Shielding

All cables must maintain high integrity 360 degree shielding. Compumotor CE cables are fully shielded and provide the required screening. When you install limit switches and other inputs/outputs, you must observe proper noise immunity standards. See the *EMC Installation* drawing at the end of this appendix.

Ferrite Absorbers

Some installations may require that you take additional EMC measures. To further increase product immunity and reduce product emissions, you may add clip-on ferrite absorbers to all cables. Compumotor recommends a ferrite with at least 200 ohm impedance at 100 MHz, such as:

Steward Ferrite	part number 28A2024
Fair-Rite	part number 0443164151

(These ferrites are available from Compumotor, part number 47-015956-01)

Enclosure Mounting the Gemini Drive

The enclosure must be properly earthed and paint must be removed from drive mounting and RF earth bonding locations. Proper shield termination of all cables entering and exiting the enclosure is required. The motor shield (braid) must be fastened to the drive using the included saddle clamp or R-Clamp. The shield must not make contact with other conductors, as this will cause common mode drive generated PWM current to flow where not expected. The shields of all other cables that enter or exit the enclosure must be RF bonded to the enclosure entrance point via R-Clamp, bulkhead clamshell clamp, or other 360° bonding technique. This ensures that no stray noise will enter or exit the enclosure. The next drawing illustrates 360° bonding techniques.

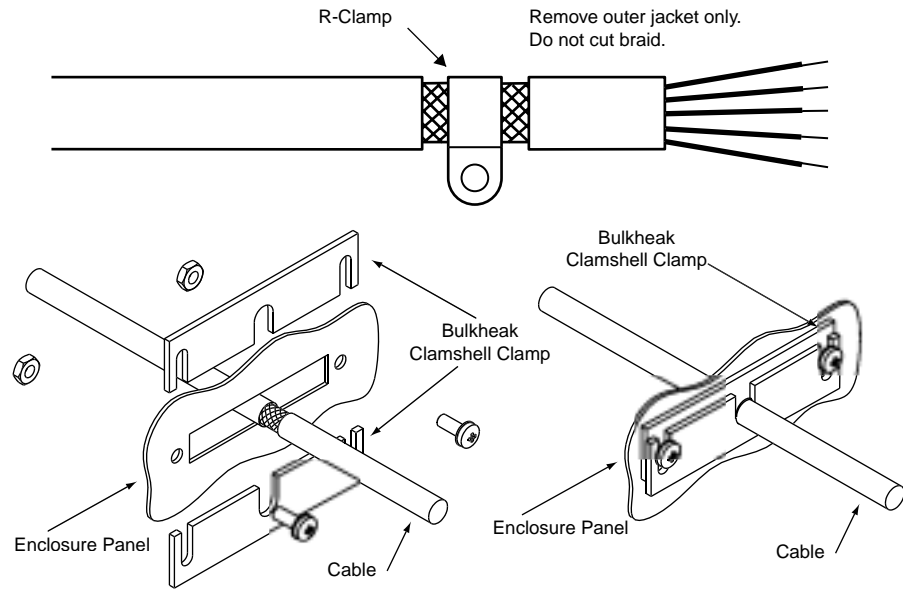

360° Bonding Techniques

The following clamps and clamp kits are available from Compumotor.

Clamp Type:	Compumotor Part Number:
R-Clamp	58-016050-01
R-Clamp Kit (10 per)	R CLAMP KIT
Bulkhead Clamshell Clamp	53-016131-01
Clamshell Clamp Kit (2 per)	CLAMSHELL KIT
Saddle Clamp	53-017355-01

If you use the GEM-VM50 or other screw terminal cable breakout device, be sure to properly enclose all exposed conductors to avoid contamination and to reduce the risk of electrostatic discharge. Limit switches and other I/O must utilize high quality shielded cabling (85% braid coverage minimum), which must be RF earth bonded as shown above.

Panel Mounting the Gemini Drive

The mounting panel must be properly earthed and paint must be removed from drive mounting locations. Gemini CE cables maintain proper RF bonding with the drive when you insert them in the correct location and tighten the headshell jackscrews. You must fasten the motor shield (braid) to the bottom of the drive, using the included saddle clamp. (GV-H20n/H40n: R-Clamp on front of drive). The shield must not make contact with other conductors, as this will cause common mode drive generated PWM current to flow where not expected.

If you use the GEM-VM50 or other screw terminal cable breakout device, be sure to properly enclose all exposed conductors to avoid contamination and to reduce the risk of electrostatic discharge. Limit switches and other I/O must utilize high quality shielded cabling (85% braid coverage minimum), which must be RF earth bonded as shown in the *360° Bonding Techniques* drawing.

System Installation

If you mount the Gemini drive in an enclosure, terminate cable braids (screens) at the entrance of the enclosure. However, the motor braid *must* be returned to the drive's saddle clamp (GV-H20n/H40n: R-Clamp on front of drive), not any other location.

The next figures show typical EMC installations.

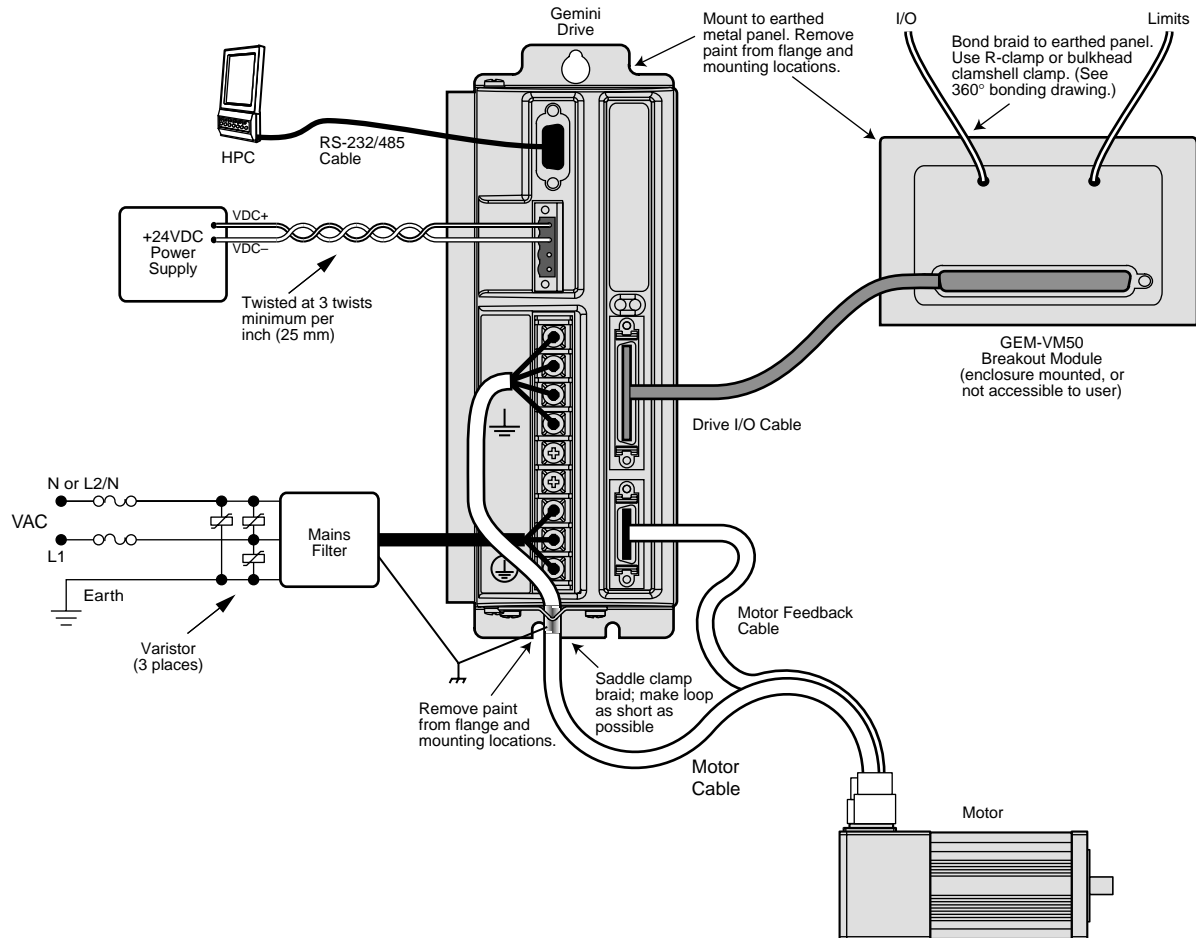

EMC Installation – GV-L3n; GV-U3n/6n/12n

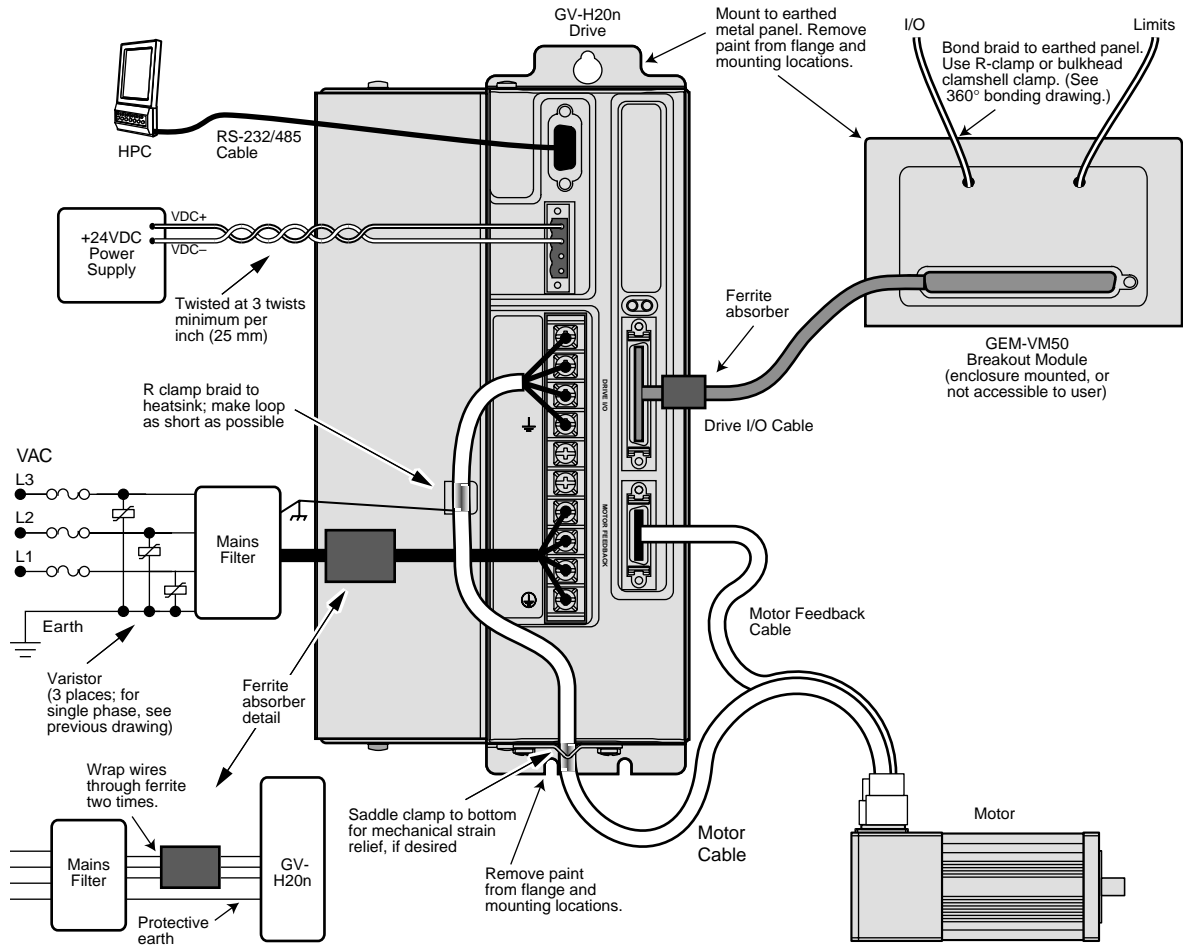

EMC Installation – GV-H20n

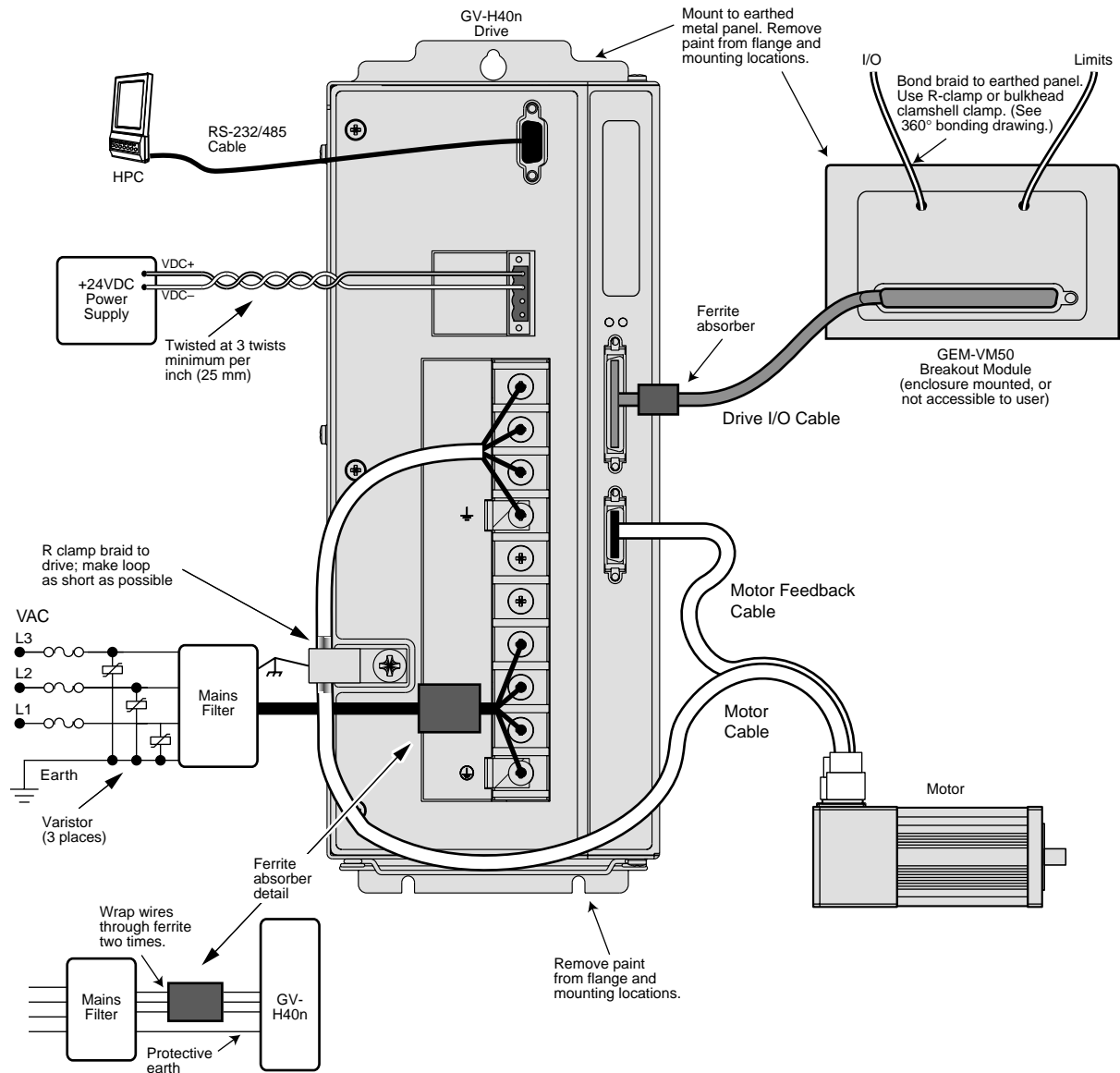

EMC Installation – GV-H40n

Index

Symbols

+24VDC keep alive power 36, 58
+24VDC power input 37
±10V command inputs 61
26 pin breakout module 80
26 pin connector kit 80
26 pin Motor Feedback connector 66
360° bonding 89
50 pin breakout module 79
50 pin Drive I/O connector 60
6200, AT6n00 connections 77
6250, AT6n50 connections 78
6K Controller 20

A

AC input voltage 16, 58
AC power 16, 58
accessories 12
accuracy 58
aligning resolver 42
analog command cable 76
analog monitor 65
autorun mode 55
axis status 52

B

bonding 89
brake 36
breakout module 79, 80

C

cabinet mounting 88
cable
 specifications 76
 troubleshooting 54
CE 4, 59, 86
CE Marking Directive 4
CNTRL-P 63
color code 78
COM port 53
command input 61
communications 59
Compumotor 6200 77
Compumotor 6250 78
Compumotor AT6n00 77
Compumotor AT6n50 78
configuration 24

configuration status 52
configure drive 18
connector
 Drive I/O 60, 66
 Motor Feedback 66
 RS-232/485 44
cUL 59, 86
current foldback 75
current limiter 74

D

descriptions 8
digital inputs 63
digital outputs 64
dimensions 69
download procedures 48
drive configuration 18, 24
drive dimensions 69
Drive I/O connector 60
drive settings 25

E

electromagnetic compatibility 86
EMC 59, 86
EMC installation 90
enable input 62
enclosure mounting 88
encoder 67
encoder outputs 64
environmental specifications 59
error log 51
express setup 12

F

fault input 63
fault output 64
fault settings 25
feedback 66
feedback cable 15
filters 33, 87
firmware 48
flying lead cable 77
foldback 75
fuses 16

G

GC-26 26 pin connector 80
GC-50 50 pin connector 80
GEM-VM50 79

GFB-KIT 26 pin connector kit 80
GPDM 39

H

Hall effects 68

I

I/O
 connector 60, 66
 pinouts 60
 settings 26
INDEB 63
INLVL 63
input voltage 58
inputs 60, 63
inrush current 74

K

keep alive power 36, 58

L

lag filter 34
lead filter 34
LEDs 50
limit input 63
limit output 64
load settings 25
loop back test 54
Low Voltage Directive 4
LVD 4, 59, 86

M

mains fuses 86
modem cable 79
Motion Planner 24
motor
 brake 36
 cable 15
 connections 14
 feedback cable 15
 overtemperature 74
 parameter table 82
 requirements 82
 settings 24
 thermal switch 68
Motor Feedback connector 66
mounting 89
multiple drives 37

N

- naming system 9
- non-Compumotor motor 82
- notch filter 33
- null modem cable
 - troubleshooting 54
 - wiring and color code 79
- numbering system 9

O

- operating system 48
- options 12
- output power 58
- outputs 60, 64
- overtemperature limits 74
- overvoltage protection 75

P

- panel mounting 89
- part numbering system 9
- pass through encoder mode 64
- performance 58
- Pocket Motion Planner 24
- position error 64
- position mode tuning 31
- Power Dissipation Module (GPDM) 39
- protective circuits 74
- pseudo encoder mode 64
- pulse inputs 61

R

- regeneration 38, 75
- regulatory agencies 86
- relay 36
- reset input 62
- resolver
 - aligning 42
 - connections 67
- RS-232 daisy chain 45, 54
- RS-232/485
 - connector 44
 - troubleshooting 53
- RS-485
 - communications 47
 - multi-drop 47

S

- serial port 44
- sharing power bus 38
- ship kit 12
- short circuit protection 74
- software commands 51
- specifications 58
- standards 59
- step and direction
 - cable 77
 - inputs 61
- system settings 25

T

- TAS 51
- TASX 52
- TCS 52
- temperature 59
- temperature limits 74
- TERRLG 51
- thermal switch 68
- torque mode tuning 28
- troubleshooting 49
- tuning
 - position mode 31
 - torque mode 28
 - velocity mode 30

U

- UL 59, 86
- undervoltage protection 75
- update procedures 48
- upload procedures 48
- user guides 10

V

- V Bus \pm 38
- varistors 87
- velocity mode tuning 30
- VINref 62
- VM50 79

W

- weight 59

RS-232/485 Connector – Configuration Port: see page 44

To configure all drive parameters, connect a PC or HPC to this port. Use Motion Planner or Pocket Motion Planner for drive configuration.

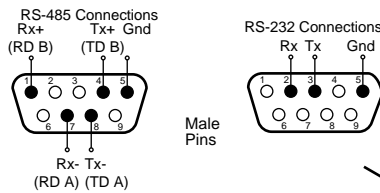

+24VDC/Relay Connector – see page 36

User supplies +24VDC for "keep alive" power to drive:
 19.2 – 28.8 VDC
 500 mA minimum

When drive is enabled, it holds relay closed.

Relay rating: 5A at 24VDC or 120VAC.

If drive is faulted or disabled, relay will open. (Typical use: control of motor brake.)

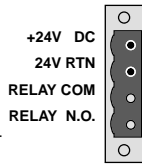

Motor Output Connections – see page 14

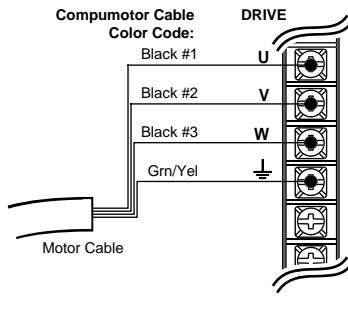

AC Input Connections – see page 16

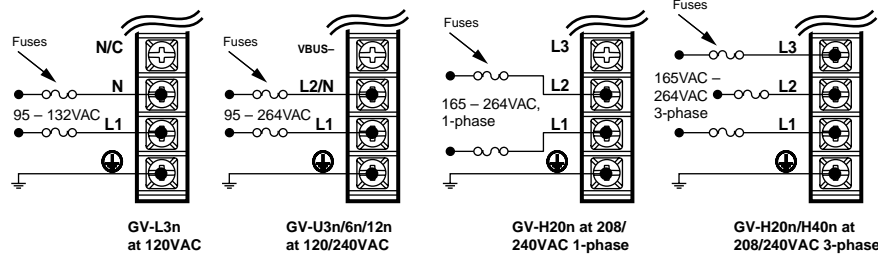

Protective Circuits – see page 74

- Short Circuit Protection
- Inrush Current Protection
- Drive Overtemperature Protection
- Motor Overtemperature Protection
- Undervoltage Protection
- Overvoltage Protection
- Current Foldback
- Regeneration Protection

Environmental Specifications – see page 59

Operating Temperature	Still Air: 45°C (113°F) Moving Air: 50°C (122°F)
Storage Temperature:	-40°C – 85°C (-40°F – 185°F)
Humidity:	0 – 95%, non-condensing
Shock:	15g, 11msec half sine
Vibration:	10 – 2000 Hz at 2g

Gemini[®] GV Servo Drive

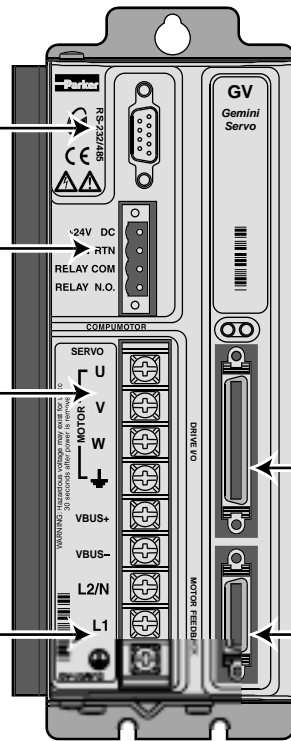

50 Pin DRIVE I/O Connector – see page 60

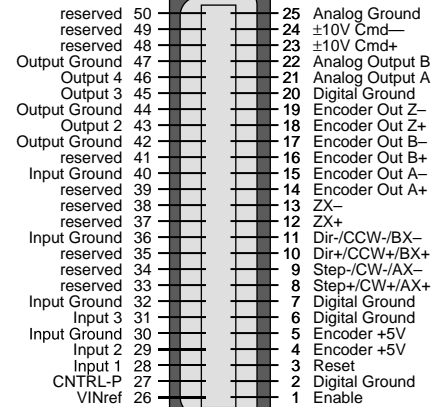

26 Pin MOTOR FEEDBACK Connector – see page 66

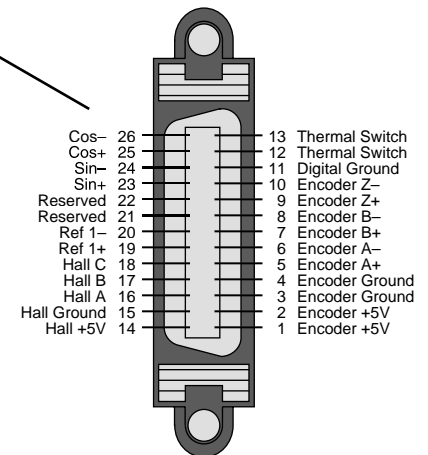

Troubleshooting – see page 49

- Commonly used status commands (binary status bits are numbered 1 to n, from left to right):
- TERRLG Error log reports the last 10 error conditions (cleared with CERRLG).
 - TAS General report, including fault conditions.
 - TASX Additional report of conditions not covered with TAS.
 - TCS If TASX bit #7 or bit #28 is set, you can identify the cause with TCS.
 - TINO Bit #6 indicates status of Enable input ("1" = OK to enable drive).
 - TIN Status of digital inputs, including end-of-travel inputs.
 - TOUT Status of digital outputs.

You must configure all motor parameters. Be sure to follow the drive configuration procedure (see *Chapter 2 Installation*). Any fault condition causes the drive to shut down.

The drive can not be enabled (DRIVE1) unless the Enable input is grounded and the Reset input is not grounded.

Use one of three methods to reset the drive (all command settings are remembered after reset):
 Issue the RESET command.
 Momentarily close the Reset input.
 Cycle power to the drive.

LEDs – see page 50

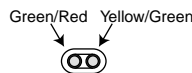

LED Color:	Indicated State
Left Off	Initialization
Right Off	Awaiting flash download
Red (flash)	Programming flash memory
Red (flash)	Keep alive mode
Red	Incoming steps (variable rate)
Grn	Autoturn mode
Grn	Drive not enabled
Grn	Drive faulted
Grn	Drive ready
Grn	Off