

ACCU ELECTRIC MOTORS INC

USA: (888) 932-9183

CANADA: (905) 829-2505

- ✓ Over 100 years cumulative experience
- ✓ 24 hour rush turnaround / technical support service
- ✓ Established in 1993



The leading independent repairer of servo motors and drives in North America.

Visit us on the web:

www.servo-repair.com

www.servorepair.ca

www.ferrocontrol.com

www.sandvikrepair.com

www.accuelectric.com

Scroll down to view your document!

For 24/7 repair services :

USA: 1 (888) 932 - 9183

Canada: 1 (905) 829 -2505

Emergency After hours: 1 (416) 624 0386

Servicing USA and Canada



HIGH PERFORMANCE SERVO MOTORS

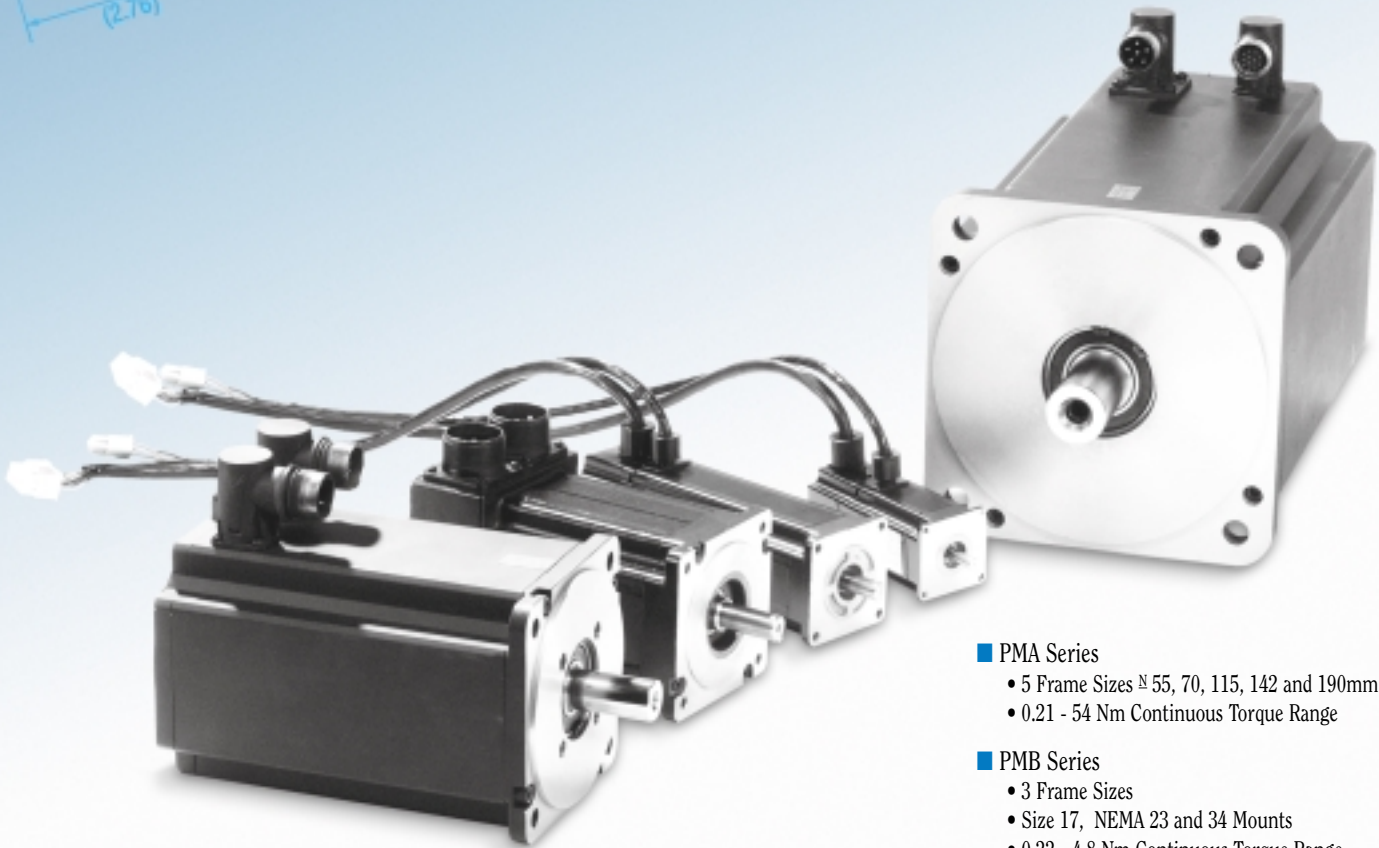

■ PMA Series

- 5 Frame Sizes \approx 55, 70, 115, 142 and 190mm Square
- 0.21 - 54 Nm Continuous Torque Range

■ PMB Series

- 3 Frame Sizes
- Size 17, NEMA 23 and 34 Mounts
- 0.22 - 4.8 Nm Continuous Torque Range

■ S Series

- 2 Frame Sizes
- Available in NEMA 23 and 34 Mounts
- 0.5 - 6.6 Nm Continuous Torque Range

■ R Series

- 5 Frame Sizes \approx 2, 3.25, 4.25, 5.75 and 7.5 Inches Square
- Explosion Proof Models Available
- 0.32 - 50 Nm Continuous Torque Range

**PACIFIC
SCIENTIFIC**

HIGH PERFORMANCE MOTORS & DRIVES

March, 2001

**ISO
9001**

PACIFIC SCIENTIFIC BRUSHLESS SERVO MOTORS



A Full Spectrum of Powerful Brushless Servomotors

Pacific Scientific servomotors are built for long, maintenance-free service life. Once installed, you probably won't have to look at them



again. The motors in the following pages feature Neodymium-iron-boron or Samarium cobalt magnets for the highest torque-to-inertia ratios possible. Anti-cog stator designs deliver smooth low-speed performance.

PMA Series

The PMA Series of brushless servomotors delivers a comprehensive line of rugged, cost-effective servomotors. Covering frame sizes from 55mm square to 190mm square and a continuous rated torque range of 0.21 to 54 Nm, these motors offer an economic means to satisfy the requirements of your application. Standard IP65 sealing and the availability of IP67 washdown duty as an option on selected models allows the PMA Series to stand up to the rigors of the factory floor. Global certifications and input voltages on most models to 650 volts assure your machine's acceptance worldwide.

PMB Series

The PMB Series of brushless servomotors introduces an IP40 construction motor in three frames; size 17 and NEMA 23 & 34 to address your need for a high-performance motor in higher-volume applications. With a continuous rated torque range from 0.22 to 4.8 Nm, the cost-effective PMB motors complement our full line of servos.

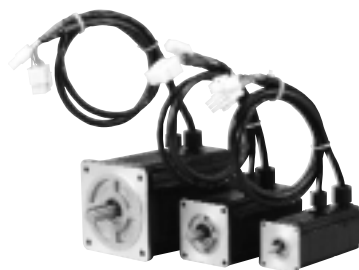

S Series

The S Series brushless servomotors offer continuous torques from 0.5 to 6.6 Nm. Available in two frame sizes with both metric and NEMA 23 & 34 mounting faces, these compact motors squeeze a lot of torque into a small package.

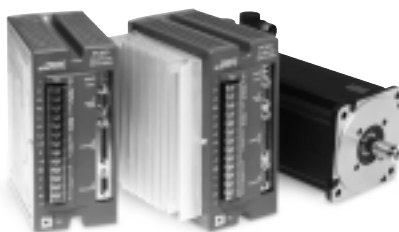

R Series

R Series servomotors offer the highest torque-to-inertia ratios in the industry. Engineered for the highest dynamic response available, these motors come in five frame sizes – both NEMA and metric mountings. The R Series covers a continuous rated torque range from 0.32 to 50 Nm.

Pacific Scientific Digital Brushless Servo Drives – Harness the Power

When these motors are combined with Pacific Scientific's broad offering of digital brushless servo drives, they offer a cost-effective, high-performance solution that's tough to beat. The systems package motors shown on pages 5 to 9 are only the tip of the iceberg. All of the brushless servomotors are customizable — often with minimal impact on delivery times. From feedback options to application-specific windings, we can help with your servo needs.

Pacific Scientific's SC/SCE900 series brushless servo drives continue to be the flagship of our servo drives. No other brushless servo drive offers higher performance. No other drive offers broader functionality.

The PC800 family of brushless servo drives offers a cost-effective, small drive with the best lead time in the industry.

BRUSHLESS SERVO MOTORS FEATURES & BENEFITS

The PC3400 Series of brushless servo drives brings to you a family of cost-effective, easy-to-use, intelligent servos from the leaders in service and performance.

Smart technology. Motion simplified.

These systems are a prime example of Pacific Scientific's commitment to offer you smart technology — the highest-performance products available, customized to suit your applications, and backed by unmatched customer support and quality. We want to help make your job easier. For more information, contact our Customer Response Center at (815) 226-3100, or visit our website at www.pacsci.com.

FEATURES	BENEFITS
PMA/S/R Series Motors	
Rugged Brushless Construction	Eliminates brush replacement maintenance Stands up to the rigors of the factory floor
High torque over wide speed range	Improved machine throughput
Anti-cog motor design	Smooth low-speed operation
IP65 TENV construction standard	Withstands rigorous environments
Two year warranty	Quality and reliability for reduced machine downtime
Class H insulation	Longer life for reduced machine downtime
Overtemperature thermistor	Protection against motor damage
Global approvals and agency recognition	Eases recognition process for a machine
Multiple feedback options	Allows numerous control methods
Brake option	Improved machine safety
PMA/S Series Motors	
IP67 protection on selected PMA models	Withstands washdown
Neodymium-iron-boron magnets	Maximum performance, maximum value
High quality Interconnectron connectors	Faster installation and maintenance
High voltage models available	Improved application flexibility
S/R Series Motors	
NEMA mounting available	Improved application flexibility
Steel bearing inserts	Longer life for reduced machine downtime
R Series Motors	
High torque-to-inertia ratios	Fast acceleration, improved dynamic response
PMB Series Motors	
MS or AMP mini Mate-N-Lock® connector options	Improved application flexibility
IP40 Construction	Improved cost-effectiveness for higher volume applications

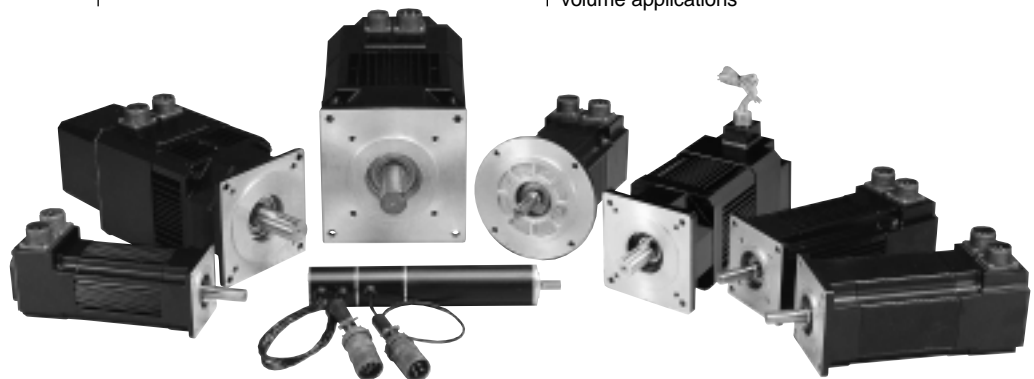

SELECTION OVERVIEW

			Typical Maximum Continuous Rated Torque (Nm) and Speed (rpm)		
			Torque Range	Speed Range	Page
48V dc bus Brushless Servomotors	PMB	PMB1	0.22 - 0.50	700 - 6,450	17
		PMB2	0.61 - 1.10	600 - 1,300	18

			Typical Maximum Continuous Rated Torque (Nm) and Speed (rpm)		
			Torque Range	Speed Range	Page
240V ac, 320V dc bus Brushless Servomotors	PMA	PMA1	0.21 - 0.60	7,000 - 9,000	11
		PMA2	0.50 - 2.2	3,000 - 6,450	12
		PMA4	3.4 - 9.9	600 - 4,700	13
		PMA5	8.8 - 20.5	900 - 3,450	14
		PMA6	24.5 - 48.5	950 - 1,750	15
	PMB	PMB1	0.14	11,000	17
		PMB2	0.45 - 1.40	4,400 - 10,000	18
		PMB3	1.62 - 4.84	1,300 - 6,000	19
	S Series	S20	0.32 - 1.5	3,400 - 12,500	21
		S30	1.9 - 6.4	1,300 - 3,900	22
	R Series	R20	0.17 - 1.0	3,000 - 11,000	24
		R30	0.76 - 3.7	1,700 - 7,000	26
		R40	3.6 - 7.3	1,500 - 5,300	27
		R60	4.4 - 17.6	1,400 - 6,000	28
		R80	10.1 - 48.6	1,200 - 4,000	29
	R Series Explosion Proof	R30P	0.62 - 3.0	1,900 - 7,000	30
R60P		3.6 - 14.4	1,500 - 6,000	31	

			Typical Maximum Continuous Rated Torque (Nm) and Speed (rpm)		
			Torque Range	Speed Range	Page
400V ac, 560V dc bus Brushless Servomotors	PMA	PMA4	3.0 - 9.5	1,600 - 6,000	13
		PMA5	7.2 - 19.0	1,900 - 4,200	14
		PMA6	19.0 - 43.8	1,350 - 3,300	15
	S Series	S30	4.0 - 4.3	3,000	22

			Typical Maximum Continuous Rated Torque (Nm) and Speed (rpm)		
			Torque Range	Speed Range	Page
480V ac, 640V dc bus Brushless Servomotors	PMA	PMA4	2.6 - 9.3	2,100 - 6,800	13
		PMA5	6.8 - 18.6	2,200 - 4,750	14
		PMA6	17.5 - 42.2	1,600 - 3,800	15
	S Series	S30	3.6 - 3.9	3,600 - 3,900	22

INDEX

How to use this selection guide

Use the selection overview on page 2 to identify motors available to fit your system voltage, torque and speed requirements. Detailed system combinations with ratings are shown on pages 5 - 9. The table of contents to the right will help you find more information on each motor family.

Information on the Pacific Scientific drives mentioned in the following pages can be found in the Pacific Scientific publication “High Performance Servo Drives.” A Copy of this publication can be obtained by calling Pacific Scientific, or you can get one by visiting our website at www.pacsci.com

- If you are already familiar with these motors and their available options, refer to the Model Number Codes on pages 10, 16, 20, 23 and 25 to verify coded information prior to ordering.
- If you are not familiar with these motors and their available options, refer to the index at the right. Note that each frame size is covered individually and the technical data (last) applies to all motors. Construct a model number after all the technical parameters, including options, are determined.

Our sizing and selection program, Optimizer™ 3.0 can be helpful in determining the correct motor for your application. Input the parameters for your specific application and specify your drive voltage, current and output type and Optimizer will find the motors that fit the bill. Ask for your copy today.

Product Overview	Inside front cover
Features	1
Selection Overview	2
How to Use This Selection Guide	3
System Performance Data	
How to Construct a System	4
System Performance Data, 48V dc bus	5
System Performance Data, 240V ac, 320V dc bus	5
System Performance Data, 400V ac, 560V dc bus	8
System Performance Data, 480V ac, 640V dc bus	9
PMA Series Brushless Servomotors	10
• Model Number Codes	
• Ratings and Characteristics	
• Metric Mount	
PMB Series Brushless Servomotors	16
• Model Number Codes	
• Ratings and Characteristics	
• NEMA Mount	
S Series Brushless Servomotors	20
• Model Number Codes	
• Ratings and Characteristics	
• Metric Mount	
R20 Series Round Brushless Servomotors	23
• Model Number Codes	
• Ratings and Characteristics	
• Metric Mount	
R Series Brushless Servomotors	25
• Model Number Codes	
• Ratings and Characteristics	
• Metric Mount	
Brushless Servomotor Feedback Combinations	32
Brushless Servomotor Brake Options	38
Brushless Servomotor Connection Options	39
Cabling and Accessories	43

HOW TO BUILD A SERVO DRIVE & MOTOR SYSTEM

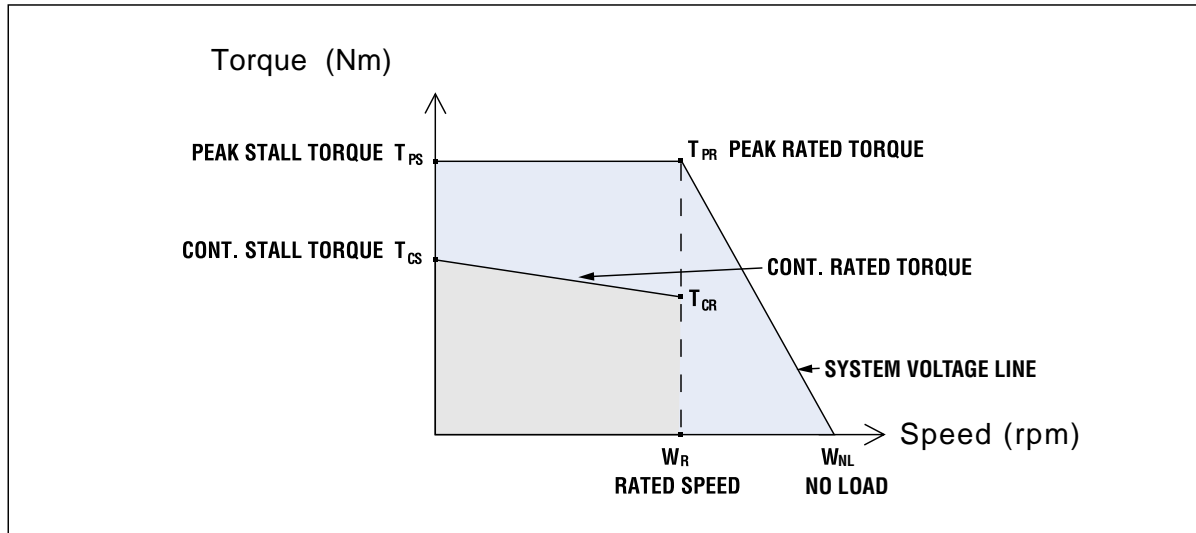

System torque/speed information on the following pages are designed to help you select the optimum brushless servo motor/controller combination.

The nominal values in this data illustrate performance for the recommended motor/controller systems.

DRIVE & MOTOR PERFORMANCE CURVES

The performance characteristics of a brushless servo system (motor/controller combination) are described by a torque/speed operating envelope. As shown above, the shaded areas of the curve indicate the continuous duty and intermittent duty zones of the system.

Continuous Duty Zone

The continuous duty zone is bordered by the maximum continuous torque line up to the rated speed of the motor.

The continuous torque line is set by either the motor's maximum rated temperature, or the controller's rated continuous current output, whichever is less. The system voltage line is set by the voltage rating of the controller, the line voltage supplied, and the motor winding.

The system can operate on a continuous basis anywhere within this area, assuming the motor temperature is 40°C or less, ambient. Refer to the Test Conditions on the pages that follow.

Intermittent Duty Zone

The intermittent duty zone is bordered by the peak torque line and the system voltage line.

The peak torque line is set by either the controller's peak current rating, which the

controller can produce for a limited time, or the maximum rated current for the motor, whichever is less. Refer to the Rating Data on the pages that follow.

NOTE: higher torque levels may be achievable at higher power levels. Consult Pacific Scientific for more details.

The system voltage line is set by the voltage rating of the controller, the line voltage applied and the motor winding.

Operation in the intermittent zone must be limited to a duty cycle that will produce an RMS system torque falling within the continuous duty area. The RMS torque value is defined by the magnitude of the intermittent torque and the percentage of the time spent at that torque.

Zero - Peak, or RMS?

Current brushless drive technology uses a sinusoidal output. Pacific Scientific rates its systems using RMS values to accurately reflect system performance operating with a sinusoidal waveform.

Older published ratings were based on 0 - peak values, using a trapezoidal waveform.

Optimizer 3.0

For more information on any motor on the following pages, or to take a closer look at

detailed torque/speed information, take a look at our sizing and selection program, Optimizer™ 3.0. With Optimizer's sine/trapezoidal conversion algorithm, you can see how our motors pair up with a trapezoidal drive, too. Call Pacific Scientific at 815-226-3100 to get your free copy today, or visit our website at www.pacsci.com.

Additional References

On the pages that follow, each individual system has reference points in a table. In addition to rating points for peak (T_{PS}) and continuous torque (T_{CS}) ratings at stall, each system has:

- Rated speed (W_R)
- Continuous torque at rated speed (T_{CR})
- Peak torque at rated speed (T_{PR})
- Motor unloaded speed (W_{NL})

To construct a curve, follow the guidelines presented in the generic curve above.

System rated speeds and torques are based on the intersection of the system voltage line and the peak current line. Differing peak currents will impact rated system speeds.

The points are provided for reference for use in comparing and sizing systems.

SYSTEMS PERFORMANCE DATA

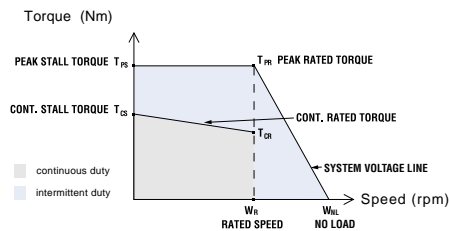

RECOMMENDED MOTOR/DRIVE SYSTEMS, 48V dc bus^{① ②}

Servo Motor Model ^⑤	Servo Drive Model	Peak Stall Torque T_{PS} ^① Nm (lb.-in.)	Peak Rated Torque T_{PR} ^② Nm (lb.-in.)	Cont. Stall Torque T_{CS} Nm (lb.-in.)	Cont. Rated Torque T_{CR} Nm (lb.-in.)	Rated Speed W_R ^③ rpm	No-Load Speed W_{NL} rpm	Cont. Stall Current I_{CS} A_{RMS}	Current at Peak Torque I_{PS} A_{RMS}	Inertia ^④ J kgm ² x 10 ⁻³ (lb.-in.-S ² x 10 ⁻³)	Inductance Line-Line L mH
PMB Series motors with PC340XD Drives											
PMB11B	PC3402	0.45 (4.0)	0.45 (4.0)	0.22 (2.0)	0.22 (2.0)	1,000	5,000	2.4	5.0	0.005 (0.045)	2.5
PMB11D	PC3405	0.45 (4.0)	0.44 (3.9)	0.22 (2.0)	0.20 (1.8)	6,450	10,000	4.8	10.0	0.005 (0.045)	0.6
PMB12B	PC3402	0.80 (7.1)	0.79 (7.0)	0.40 (3.5)	0.40 (3.5)	700	2,900	2.5	5.0	0.009 (0.079)	3.3
PMB12D	PC3405	0.83 (7.3)	0.82 (7.3)	0.40 (3.5)	0.38 (3.3)	3,500	5,600	4.7	10.0	0.009 (0.079)	0.9
PMB13D	PC3405	1.11 (9.8)	1.10 (9.7)	0.55 (4.9)	0.50 (4.4)	2,350	4,150	4.8	10.0	0.013 (0.113)	1.1
PMB21D	PC3405	1.27 (11.2)	1.26 (11.2)	0.64 (5.7)	0.61 (5.4)	1,300	3,600	5.0	10.0	0.023 (0.201)	1.2
PMB22D	PC3405	2.2 (19.5)	2.2 (19.5)	1.11 (9.8)	1.10 (9.7)	600	2,150	5.0	10.0	0.044 (0.385)	1.5

- ① See page 4 for definitions of ratings.
- ② Peak torque ratings are for 1 second.
- ③ 48V dc figures shown for reference. Operation available from 18-74V dc.
- ④ DC drives offer operation with encoder feedback only. Inertia figures include encoder feedback.
- ⑤ Each system requires one feedback and one motor power cable.

RECOMMENDED MOTOR/DRIVE SYSTEMS, 240V ac, 320V dc bus^①

Servo Motor Model ^⑤	Servo Drive Model	Peak Stall Torque T_{PS} ^① Nm (lb.-in.)	Peak Rated Torque T_{PR} Nm (lb.-in.)	Cont. Stall Torque T_{CS} Nm (lb.-in.)	Cont. Rated Torque T_{CR} Nm (lb.-in.)	Rated Speed W_R ^③ rpm	No-Load Speed W_{NL} rpm	Cont. Stall Current I_{CS} A_{RMS}	Current at Peak Torque I_{PS} A_{RMS}	Inertia ^② J kgm ² x 10 ⁻³ (lb.-in.-S ² x 10 ⁻³)	Inductance Line-Line L mH
PMA Series motors with PC8xx and SC9xx Drives											
PMA11A	PC8x2, SC9x2/SCE9x2 ^②	1.4 (12.4)	1.4 (12.4)	0.26 (2.3)	0.22 (1.9)	6,600	12,900	0.96	5.3	0.012 (0.102)	7.1
PMA12A	PC8x2, SC9x2/SCE9x2 ^②	1.7 (14.8)	1.7 (14.7)	0.6 (5.3)	0.47 (4.2)	8,500	10,800	1.88	5.3	0.019 (0.164)	4.3
PMA13B	PC8x2, SC9x2/SCE9x2 ^②	1.7 (15.3)	1.7 (15.2)	0.9 (8.0)	0.6 (5.3)	9,000	10,600	2.73	5.3	0.026 (0.226)	2.7
PMA21B	PC8x2, SC9x2/SCE9x2 ^②	1.8 (16.3)	1.8 (16.2)	0.63 (5.6)	0.50 (4.4)	6,050	9,250	1.72	5.3	0.022 (0.19)	10.5
PMA22B	PC8x3, SC9x3 ^③	4.7 (42.0)	4.7 (41.9)	1.3 (11.5)	1.1 (9.4)	4,650	7,100	2.65	10.6	0.038 (0.34)	7.4
PMA22B	PC8x2, SC9x2/SCE9x2 ^②	2.6 (22.7)	2.5 (22.5)	1.3 (11.5)	1.0 (8.9)	5,750	7,100	2.65	5.3	0.038 (0.34)	7.4
PMA23B	PC8x2, SC9x2/SCE9x2 ^②	3.9 (34.2)	3.9 (34.1)	2.0 (17.7)	1.6 (14.6)	3,600	4,700	2.7	5.3	0.055 (0.49)	6.8
PMA23C	PC8x3 ^③	5.9 (52.4)	5.9 (52.2)	2.0 (17.7)	1.6 (14.2)	4,200	5,850	3.4	10.6	0.055 (0.49)	10.6
PMA23D	PC8x4 ^④	7.3 (64.6)	7.3 (64.3)	2.0 (17.7)	1.4 (12.3)	6,400	8,750	5.0	20.0	0.055 (0.49)	3.0
PMA23D	SC9x3 ^③	4.2 (36.8)	4.1 (36.6)	2.0 (17.7)	1.3 (11.5)	7,400	8,750	5.0	10.6	0.055 (0.49)	3.0
PMA24C	PC8x3 ^③	7.9 (70.2)	7.9 (70.9)	2.6 (23.0)	2.2 (19.5)	3,000	4,350	3.3	10.6	0.072 (0.64)	8.9
PMA24D	PC8x4 ^④	9.5 (84.1)	9.5 (83.8)	2.6 (23.0)	1.9 (17.2)	4,950	6,950	5.3	21.2	0.072 (0.64)	3.5
PMA24D	SC9x3 ^③	5.1 (45.3)	5.1 (45.0)	2.6 (23.0)	1.8 (16.1)	5,850	6,950	5.3	10.6	0.072 (0.64)	3.5
PMA42M	PC8x2, SC9x2/SCE9x2 ^②	7.7 (67.9)	7.6 (67.7)	4.1 (36.3)	3.9 (34.5)	1,600	2,350	2.8	5.3	0.36 (3.2)	26.0
PMA42N	PC8x3 ^③	11.3 (99.9)	11.2 (99.6)	4.0 (35.4)	3.8 (33.6)	1,950	3,100	3.6	10.6	0.36 (3.2)	14.3
PMA42P	SC903 ^③	9.1 (80.4)	9.0 (79.9)	4.1 (36.3)	3.6 (31.9)	2,950	4,000	4.7	10.6	0.36 (3.2)	8.9
PMA42Q	PC8x4 ^④	12.6 (111)	12.5 (111)	4.1 (36.3)	3.4 (30.1)	3,800	5,450	6.5	21.2	0.36 (3.2)	4.7
PMA43N	PC8x3 ^③	16.9 (149)	16.8 (149)	5.9 (52.2)	5.8 (51.3)	1,250	2,050	3.6	10.6	0.52 (4.6)	20.0
PMA43P	SC903 ^③	13.8 (122)	13.8 (122)	6.1 (54.0)	5.6 (49.6)	1,850	2,600	4.6	10.6	0.52 (4.6)	13.0
PMA43Q	PC8x4 ^④	17.3 (153)	17.2 (152)	6.0 (53.2)	5.2 (46.0)	3,000	4,050	7.1	21.2	0.52 (4.6)	5.3
PMA43R	SC904 ^④	12.6 (112)	12.5 (111)	6.1 (54.0)	4.5 (39.8)	4,700	5,650	10.1	21.2	0.52 (4.6)	2.7
PMA44N	PC8x3 ^③	23.3 (206)	23.2 (206)	8.2 (72.6)	7.9 (70.0)	850	1,550	3.6	10.6	0.68 (6.0)	27.0
PMA44P	PC8x3 ^③	15.9 (141)	15.9 (140)	8.0 (71.3)	7.4 (65.5)	1,750	2,250	5.3	10.6	0.68 (6.0)	12.4
PMA44Q	PC8x4 ^④	23.2 (205)	23.1 (205)	8.1 (71.6)	7.3 (64.4)	2,100	3,000	7.1	21.2	0.68 (6.0)	7.1
PMA44R	SC904 ^④	17.0 (150)	16.9 (149)	8.2 (72.6)	6.7 (59.3)	3,450	4,200	10.1	21.2	0.68 (6.0)	3.6
PMA45N	PC8x3 ^③	29.0 (256)	28.9 (256)	10.2 (90.3)	9.9 (87.6)	600	1,200	3.6	10.6	0.84 (7.4)	33.0
PMA45Q	PC8x4 ^④	29.3 (259)	29.2 (258)	10.2 (90.3)	9.4 (83.2)	1,650	2,350	7.1	21.2	0.84 (7.4)	8.7
PMA45R	SC904 ^④	21.3 (189)	21.2 (188)	10.2 (90.3)	8.9 (78.8)	2,700	3,300	10.0	21.2	0.84 (7.3)	4.4
PMA53Q	PC8x4 ^④	26.9 (238)	26.8 (237)	10.5 (92.9)	9.6 (85.0)	1,300	2,250	6.8	21.2	1.92 (17.0)	15.0
PMA53R	SC904 ^④	20.6 (182)	20.5 (181)	10.5 (92.9)	8.8 (77.9)	2,350	3,200	9.7	21.2	1.92 (17.0)	7.2
PMA54Q	PC8x4 ^④	34.1 (302)	34.1 (301)	13.5 (120)	12.4 (110)	1,200	1,800	7.1	21.2	2.49 (22.0)	16.0
PMA54R	SC904 ^④	24.7 (219)	24.6 (218)	13.5 (120)	11.6 (103)	2,100	2,700	10.6	21.2	2.49 (22.0)	7.1

- ① See page 4 for definitions of ratings.
- ② Peak torque ratings are for 5 seconds.
- ③ Peak torque ratings are for 2 seconds.
- ④ Peak torque ratings are for 1 second.
- ⑤ Peak torque ratings are for .5 second.
- ⑥ Rated speed is provided for operation on 240V ac 3-phase line. Reduce to approximately 85% for 240V ac 1-phase line operation and to 40% for 120V ac 1-phase line operation.
- ⑦ Includes resolver feedback inertia.
- ⑧ Each system requires one feedback and one motor power cable.
- ⑨ Characteristics shown with drive default parameters limited to 2.5x the motor's continuous rating. Higher peak system performance available. Contact the factory.

SYSTEMS PERFORMANCE DATA

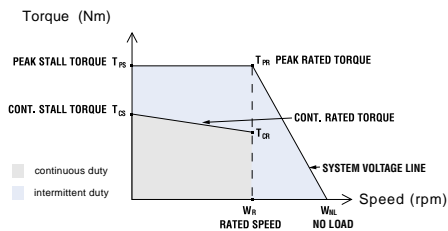

RECOMMENDED MOTOR/DRIVE SYSTEMS, 240V ac, 320V dc bus^① continued

Servo Motor Model ^②	Servo Drive Model	Peak Stall Torque T_{PS} ^③ Nm (lb.-in.)	Peak Rated Torque T_{PR} Nm (lb.-in.)	Cont. Stall Torque T_{CS} Nm (lb.-in.)	Cont. Rated Torque T_{CR} Nm (lb.-in.)	Rated Speed W_R ^④ rpm	No-Load Speed W_{NL} rpm	Cont. Stall Current I_{CS} A_{RMS}	Current at Peak Torque I_{PS} A_{RMS}	Inertia ^⑦ J kgm ² x 10 ⁻³ (lb.-in.-S ² x 10 ⁻³)	Inductance Line-Line L mH
PMA55Q	PC8x4 ^②	43.0 (380)	42.9 (379)	17.0 (151)	16.0 (141)	900	1,450	7.1	21.2	3.06 (27.1)	20.0
PMA55R	SC904 ^②	31.1 (276)	31.0 (274)	17.0 (151)	15.2 (135)	1,650	2,150	10.6	21.2	3.06 (27.1)	8.8
PMA55S	SC905 ^②	31.0 (274)	30.7 (272)	17.0 (151)	13.1 (116)	3,450	4,300	21.3	42.4	3.06 (27.1)	2.2
PMA57R	SC904 ^②	43.6 (386)	43.5 (384)	22.0 (195)	20.5 (181)	1,150	1,550	9.8	21.2	4.21 (37.3)	12.5
PMA57S	SC905 ^②	43.8 (388)	43.6 (386)	22.0 (195)	18.4 (163)	2,450	3,050	19.5	42.4	4.21 (37.3)	3.1
PMA65S	SC905 ^②	56.8 (503)	56.6 (501)	30.0 (266)	24.5 (217)	1,750	2,400	20.9	42.4	7.9 (70.0)	5.9
PMA66S	SC905 ^②	68.9 (609)	68.6 (607)	36.0 (319)	31.0 (274)	1,450	2,000	20.7	42.4	9.4 (83.3)	7.0
PMA67S	SC905 ^②	80.3 (711)	80.1 (709)	42.0 (372)	37.0 (328)	1,250	1,700	20.7	42.4	10.9 (96.5)	8.2
PMA69S	SC905 ^②	104 (919)	104 (917)	54.0 (478)	48.5 (429)	950	1,300	20.6	42.4	13.9 (123)	10.4
PMA Series motors with PC34xxA Drives											
PMA11A	PC3403 ^③	.64 (5.7)	.64 (5.7)	0.26 (2.3)	0.18 (1.6)	10,000	12,900	0.96	2.4 ^⑤	0.012 (0.102)	7.1
PMA12A	PC3403 ^③	1.5 (13.3)	1.5 (13.3)	0.6 (5.3)	0.47 (4.2)	8,750	10,800	1.88	4.7 ^⑤	0.019 (0.164)	4.3
PMA13B	PC3403 ^③	1.9 (17.3)	1.9 (17.2)	0.9 (8.0)	0.6 (5.4)	8,800	10,600	2.73	6.0	0.026 (0.226)	2.7
PMA21B	PC3403 ^③	1.5 (13.5)	1.5 (13.5)	0.63 (5.6)	0.47 (4.2)	6,800	9,250	1.72	4.3 ^⑤	0.022 (0.19)	10.5
PMA22B	PC3403 ^③	2.9 (25.5)	2.9 (25.3)	1.3 (11.5)	1.0 (9.0)	5,600	7,100	2.65	6.0	0.038 (0.34)	7.4
PMA23B	PC3403 ^③	4.3 (38.5)	4.3 (38.3)	2.0 (17.7)	1.7 (14.7)	3,550	4,700	2.7	6.0	0.055 (0.49)	6.8
PMA23C	PC3403 ^③	3.5 (30.8)	3.5 (30.6)	1.8 (15.6)	1.5 (13.6)	4,900	5,850	3.0	6.0	0.055 (0.49)	10.6
PMA23D	PC3406 ^③	4.7 (41.2)	4.7 (41.1)	2.0 (17.7)	1.3 (11.7)	7,200	8,750	5.0	12.0	0.055 (0.49)	3.0
PMA24C	PC3403 ^③	4.7 (41.2)	4.6 (41.1)	2.4 (20.9)	2.1 (18.8)	3,600	4,350	3.0	6.0	0.072 (0.64)	8.9
PMA24D	PC3406 ^③	5.8 (51.6)	5.7 (51.0)	2.6 (23.0)	1.8 (16.1)	5,800	6,950	5.3	12.0	0.072 (0.64)	3.5
PMA42M	PC3403 ^③	8.6 (76.5)	8.6 (76.3)	4.1 (36.3)	3.9 (34.6)	1,500	2,350	2.8	6.0	0.36 (3.2)	26.0
PMA42Q	PC3406 ^③	7.5 (66.3)	7.4 (65.7)	3.8 (33.5)	3.1 (27.4)	4,500	5,450	6.0	12.0	0.36 (3.2)	4.7
PMA42Q	PC3410 ^③	9.9 (88.1)	9.9 (87.5)	4.1 (36.3)	3.2 (28.3)	4,150	5,450	6.5	16.2 ^⑥	0.36 (3.2)	4.7
PMA43N	PC3403 ^③	9.8 (87.0)	9.8 (86.6)	4.9 (43.4)	4.8 (42.5)	1,600	2,050	3.0	6.0	0.52 (4.6)	20.0
PMA43P	PC3406 ^③	14.9 (132)	14.9 (131)	6.1 (54.0)	5.6 (49.6)	1,800	2,600	4.6	11.5 ^⑥	0.52 (4.6)	13.0
PMA43R	PC3410 ^③	11.9 (106)	11.8 (105)	6.0 (53.5)	4.5 (39.6)	4,750	5,650	10.0	20.0	0.52 (4.6)	2.7
PMA44N	PC3403 ^③	13.6 (120)	13.5 (120)	6.8 (60.5)	6.7 (59.3)	1,100	1,550	3.0	6.0	0.68 (6.0)	27.0
PMA44P	PC3406 ^③	17.9 (159)	17.9 (158)	8.2 (72.6)	7.5 (65.9)	1,650	2,250	5.4	12.0	0.68 (6.0)	12.4
PMA44R	PC3410 ^③	16.1 (142)	15.9 (141)	8.1 (71.8)	6.7 (59.1)	3,500	4,200	10.0	20.0	0.68 (6.0)	3.6
PMA45N	PC3403 ^③	16.9 (150)	16.9 (149)	8.5 (75.2)	8.4 (74.8)	850	1,200	3.0	6.0	0.84 (7.4)	33.0
PMA45N	PC3406 ^③	25.0 (221)	25.0 (221)	10.2 (90.3)	9.9 (87.5)	650	1,200	3.6	9.0 ^⑥	0.84 (7.4)	33.0
PMA45R	PC3410 ^③	20.2 (179)	20.0 (178)	10.2 (90.3)	8.9 (78.6)	2,750	3,300	10.0	20.0	0.84 (7.3)	4.4
PMA53Q	PC3406 ^③	17.1 (151)	17.0 (150)	9.2 (81.4)	9.1 (80.5)	1,650	2,250	6.0	12.0	1.92 (17.0)	15.0
PMA53R	PC3410 ^③	19.6 (173)	19.5 (172)	10.5 (92.9)	8.6 (76.5)	2,400	3,200	9.7	20.0	1.92 (17.0)	7.2
PMA54R	PC3410 ^③	23.5 (208)	23.4 (207)	12.7 (113)	11.6 (103)	2,100	2,700	10.0	20.0	2.49 (22.0)	7.1
PMA55R	PC3410 ^③	29.6 (262)	29.5 (261)	16.0 (142)	15.2 (135)	1,700	2,150	10.0	20.0	3.06 (27.1)	8.8
PMA55S	PC3420 ^③	29.4 (261)	29.2 (258)	16.0 (142)	13.1 (116)	3,500	4,300	20.0	40.0	3.06 (27.1)	2.2
PMA57R	PC3410 ^③	41.4 (367)	41.3 (366)	22.0 (195)	20.5 (181)	1,200	1,550	9.8	20.0	4.21 (37.3)	12.5
PMA57S	PC3420 ^③	41.6 (369)	41.4 (366)	22.0 (195)	18.3 (162)	2,500	3,050	19.5	40.0	4.21 (37.3)	3.1
MA65S	PC3420 ^③	53.9 (477)	53.7 (475)	28.7 (254)	24.5 (217)	1,800	2,400	20.0	40.0	7.9 (70.0)	5.9
PMA66S	PC3420 ^③	65.3 (578)	65.1 (576)	34.8 (308)	31.0 (274)	1,450	2,000	20.0	40.0	9.4 (83.3)	7.0
PMA67S	PC3420 ^③	76.2 (675)	76.0 (673)	40.6 (359)	37.0 (328)	1,250	1,700	20.0	40.0	10.9 (96.5)	8.2
PMA69S	PC3420 ^③	98.5 (872)	98.3 (870)	52.4 (464)	48.5 (429)	950	1,300	20.0	40.0	13.9 (123)	10.4
PMB Series motors with PC8xx and SC9xx Drives											
PMB13B	PC8x2, SC9x2/SCE9x2 ^③	1.2 (10.9)	1.2 (10.5)	0.55 (4.9)	0.41 (3.6)	11,000	13,100	2.3	5.3	0.013 (0.118)	4.8
PMB21B	PC8x2, SC9x2/SCE9x2 ^③	1.3 (11.5)	1.3 (11.2)	0.64 (5.7)	0.45 (4.0)	10,000	13,100	2.6	5.3	0.023 (0.206)	4.0
PMB22B	PC8x2, SC9x2/SCE9x2 ^③	2.2 (19.2)	2.1 (18.9)	1.1 (9.8)	1.0 (8.9)	6,250	7,700	2.7	5.3	0.044 (0.390)	5.5
PMB23B	PC8x2, SC9x2/SCE9x2 ^③	2.9 (26.1)	2.9 (25.8)	1.5 (13.6)	1.4 (12.4)	4,400	5,650	2.7	5.3	0.065 (0.576)	7.1
PMB23C	PC8x3, SC9x3 ^③	4.5 (39.8)	4.4 (39.4)	1.5 (13.6)	1.4 (12.0)	5,750	7,400	3.5	10.5	0.065 (0.576)	3.7
PMB31B	PC8x2, SC9x2/SCE9x2 ^③	4.1 (36.6)	4.1 (36.5)	2.1 (18.7)	1.9 (16.8)	2,900	4,300	2.7	5.3	0.14 (1.21)	19.6
PMB31D	PC8x4 ^②	6.2 (55.0)	6.2 (54.7)	2.1 (18.7)	1.7 (15.0)	5,000	8,400	5.1	15.3	0.14 (1.21)	5.2

① See page 4 for definitions of ratings.

② Peak torque ratings are for 5 seconds.

③ Peak torque ratings are for 2 seconds.

④ Peak torque ratings are for 1 second.

⑤ Peak torque ratings are for .5 second.

⑥ Rated speed is provided for operation on 240V ac 3-phase line. Reduce to approximately 85% for 240V ac 1-phase line operation and to 40% for 120V ac 1-phase line operation.

⑦ Includes resolver feedback inertia.

⑧ Each system requires one feedback and one motor power cable.

⑨ Characteristics shown with drive default parameters limited to 2.5x the motor's continuous rating. Higher peak system performance available. Contact the factory.

SYSTEMS PERFORMANCE DATA

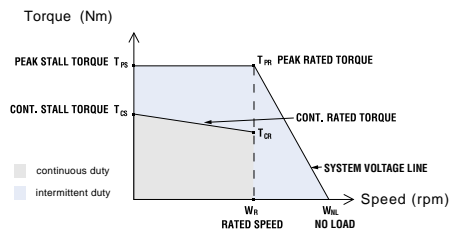

RECOMMENDED MOTOR/DRIVE SYSTEMS, 240V ac, 320V dc bus^① continued

Servo Motor Model ^②	Servo Drive Model	Peak Stall Torque T _{PS} Nm (lb.-in.)	Peak Rated Torque T _{PR} ^③ Nm (lb.-in.)	Cont. Stall Torque T _{CS} Nm (lb.-in.)	Cont. Rated Torque T _{CR} Nm (lb.-in.)	Rated Speed W _R ^④ rpm	No-Load Speed W _{NL} rpm	Cont. Stall Current I _{CS} A _{RMS}	Current at Peak Torque I _{PS} A _{RMS}	Inertia ^⑦ J kgm ² x 10 ⁻³ (lb.-in.-S ² x 10 ⁻³)	Inductance Line-Line L mH
PMB31D	SC903 ^②	4.3 (38.2)	4.3 (37.9)	2.1 (18.7)	1.6 (14.3)	6,000	8,400	5.1	10.6	0.14 (1.21)	5.2
PMB32C	PC8x2, SC9x2/SCE9x2 ^②	6.8 (60.3)	6.8 (60.0)	3.5 (30.6)	3.0 (26.4)	1,900	2,550	2.7	5.3	0.27 (2.39)	22.5
PMB32C	PC8x3, SC9x3 ^②	11.4 (101)	11.4 (101)	3.8 (34.0)	3.2 (28.4)	1,400	2,550	3.0	8.9	0.27 (2.39)	22.5
PMB32D	SC9x3 ^②	7.7 (68.4)	7.7 (68.0)	3.8 (34.0)	2.8 (25.2)	3,500	4,550	5.2	10.6	0.27 (2.39)	7.4
PMB32D	PC8x4, SC9x4 ^②	11.3 (100)	11.3 (100)	3.8 (34.0)	3.0 (26.5)	3,000	4,550	5.2	15.6	0.27 (2.39)	7.4
PMB32E	PC8x4, SC9x4 ^②	11.3 (100)	11.3 (100)	3.8 (34.0)	2.8 (25.1)	4,150	5,950	6.8	20.4	0.27 (2.39)	4.2
PMB33C	PC8x2, SC9x2/SCE9x2 ^②	9.7 (86.3)	9.7 (86.0)	5.0 (44.5)	4.8 (42.8)	1,300	1,900	2.7	5.3	0.40 (3.57)	27.2
PMB33C	PC8x3, SC9x3 ^②	15.9 (141)	15.9 (141)	5.4 (48.0)	5.0 (44.3)	950	1,900	2.9	8.7	0.40 (3.57)	27.2
PMB33E	SC9x3 ^②	9.7 (86.0)	9.7 (85.5)	4.9 (43.6)	4.4 (39.0)	3,000	3,800	5.3	10.6	0.40 (3.57)	6.8
PMB33E	PC8x4, SC9x4 ^②	16.0 (142)	15.9 (141)	5.4 (48.0)	4.6 (40.4)	2,550	3,800	5.8	17.5	0.40 (3.57)	6.8
PMB33F	SC9x4 ^②	12.5 (111)	12.5 (111)	5.4 (48.0)	4.1 (36.0)	4,500	5,700	9.0	21.2	0.40 (3.57)	2.8
PMB Series motors with PC34xx Drives											
PMB13B	PC3403 ^③	1.4 (12.2)	1.3 (11.9)	0.55 (4.9)	0.41 (3.6)	11,000	13,100	2.3	6.0	0.013 (0.113)	4.8
PMB21B	PC3403 ^③	1.5 (13.0)	1.4 (12.7)	0.64 (5.7)	0.45 (4.0)	10,000	13,100	2.6	4.7 ^⑧	0.023 (0.206)	4.0
PMB22B	PC3403 ^③	2.5 (21.8)	2.4 (21.4)	1.1 (9.8)	1.0 (9.0)	6,050	7,700	2.7	6.0	0.044 (0.390)	5.5
PMB23B	PC3403 ^③	3.3 (29.6)	3.3 (29.3)	1.5 (13.6)	1.4 (12.4)	4,200	5,650	2.7	6.0	0.065 (0.576)	7.1
PMB23C	PC3403 ^③	2.6 (22.7)	2.5 (22.2)	1.3 (11.7)	1.2 (10.6)	6,450	7,400	3.0	6.0	0.065 (0.576)	3.7
PMB23C	PC3406 ^③	3.7 (33.0)	3.7 (32.6)	1.5 (13.6)	1.3 (11.9)	6,000	7,400	3.5	8.7 ^⑧	0.065 (0.576)	3.7
PMB31B	PC3403 ^③	4.7 (41.4)	4.7 (41.3)	2.1 (18.7)	1.9 (16.9)	2,700	4,300	2.7	6.0	0.14 (1.21)	19.6
PMB31D	PC3406 ^③	4.9 (43.3)	4.8 (42.9)	2.1 (18.7)	1.6 (14.5)	5,750	8,400	5.1	12.0	0.14 (1.21)	5.2
PMB32C	PC3403 ^③	7.7 (68.2)	7.7 (68.0)	3.8 (34.0)	3.0 (26.8)	1,800	2,550	3.0	6.0	0.27 (2.39)	22.5
PMB32D	PC3406 ^③	8.7 (77.3)	8.7 (77.0)	3.8 (34.0)	2.9 (25.5)	3,400	4,550	5.2	12.0	0.27 (2.39)	7.4
PMB32E	PC3410 ^④	9.5 (83.8)	9.4 (83.3)	3.8 (34.0)	2.8 (24.5)	4,450	5,950	6.8	17.0 ^⑧	0.27 (2.39)	4.2
PMB33C	PC3403 ^③	11.0 (97.4)	11.0 (97.4)	5.4 (48.0)	4.9 (43.0)	1,250	1,900	2.9	6.0	0.40 (3.57)	27.2
PMB33E	PC3406 ^③	11.0 (97.4)	10.9 (96.5)	5.4 (48.0)	4.4 (39.3)	2,900	3,800	5.8	12.0	0.40 (3.57)	6.8
PMB33F	PC3410 ^④	11.8 (104)	11.7 (104)	5.4 (48.0)	4.0 (35.8)	4,600	5,700	9.0	20.0	0.40 (3.57)	2.8
S Series motors with PC8xx and SC9xx Drives											
S21H	PC8x3 ^②	1.4 (12.5)	1.4 (12.3)	0.51 (4.5)	0.32 (2.8)	12,500	12,500	3.1	9.3	0.042 (0.38)	3.7
S21H	PC8x2, SC9x2/SCE9x2 ^②	0.82 (7.3)	0.80 (7.1)	0.43 (3.8)	0.27 (2.4)	12,500	12,500	2.65	5.3	0.042 (0.38)	3.7
S22H	PC8x3 ^②	2.6 (23.1)	2.6 (22.9)	1.0 (8.8)	0.68 (6.0)	7,600	10,400	2.9	8.6	0.064 (0.56)	5.7
S22H	PC8x2, SC9x2/SCE9x2 ^②	1.6 (14.6)	1.6 (14.3)	0.90 (8.0)	0.59 (5.2)	9,100	10,400	2.65	5.3	0.064 (0.56)	5.7
S24G	PC8x3 ^②	5.1 (44.7)	5.0 (44.5)	1.6 (14.4)	1.5 (12.9)	3,400	4,900	2.6	7.8	0.100 (0.89)	9.3
S24G	PC8x2, SC9x2/SCE9x2 ^②	3.5 (30.9)	3.5 (30.7)	1.6 (14.4)	1.4 (12.5)	4,000	4,900	2.6	5.3	0.100 (0.89)	9.3
S24H	PC8x4 ^②	5.0 (44.1)	4.9 (43.6)	1.6 (14.4)	0.55 (4.9)	8,000	9,800	5.1	15.4	0.100 (0.89)	2.2
S24H	SC9x3 ^②	3.5 (30.9)	3.4 (30.4)	1.6 (14.4)	0.55 (4.9)	8,000	9,800	5.1	10.6	0.100 (0.89)	2.2
S31H	PC8x3 ^②	6.6 (58.8)	6.6 (58.5)	2.3 (20.0)	1.9 (16.6)	3,500	5,200	3.3	10.6	0.18 (1.58)	10.3
S31H	PC8x2, SC9x2/SCE9x2 ^②	3.4 (29.8)	3.3 (29.4)	1.8 (16.0)	1.4 (12.4)	4,600	5,200	2.65	5.3	0.18 (1.58)	10.3
S32G	PC8x3 ^②	13.0 (115)	13.0 (115)	4.0 (35.6)	3.6 (32.3)	1,500	2,600	3.1	10.6	0.34 (2.98)	18
S32G	PC8x2, SC9x2/SCE9x2 ^②	6.6 (58.4)	6.6 (58.0)	3.4 (30.4)	3.0 (26.2)	2,200	2,600	2.65	5.3	0.34 (2.98)	18
S32H	PC8x4 ^②	13.0 (115)	12.9 (114)	4.0 (35.6)	2.8 (24.9)	3,900	5,300	6.1	21.2	0.34 (2.98)	4.5
S32H	SC9x3 ^②	6.6 (58.4)	6.5 (57.6)	3.5 (30.9)	2.2 (19.5)	4,800	5,300	5.3	10.6	0.34 (2.98)	4.5
S33A	PC8x3 ^②	15.6 (138)	15.6 (138)	5.3 (47.0)	4.7 (41.3)	1,500	2,200	3.5	10.6	0.48 (4.28)	17
S33D	PC8x4 ^②	15.6 (138)	15.5 (137)	5.3 (46.9)	3.7 (32.6)	3,600	4,400	7.0	21.2	0.48 (4.28)	4.4
S33D	SC9x4 ^②	15.6 (138)	15.5 (137)	5.3 (46.9)	3.7 (32.6)	3,600	4,400	7.0	21.2	0.48 (4.28)	4.4
S33G	PC8x2, SC9x2/SCE9x2 ^②	9.7 (86.2)	9.7 (85.9)	5.0 (44.6)	4.6 (40.5)	1,400	1,800	2.65	5.3	0.48 (4.28)	25.2
S33H	SC9x3 ^②	9.7 (86.2)	9.7 (85.6)	5.0 (44.6)	3.7 (32.6)	3,200	3,600	5.3	10.6	0.48 (4.28)	6.3
S34A	PC8x3 ^②	17.5 (155)	17.4 (154)	6.0 (53.5)	5.1 (45.5)	1,500	2,000	3.6	10.6	0.64 (5.68)	14.7
S34G	PC8x2, SC9x2/SCE9x2 ^②	11.0 (97.3)	10.9 (96.8)	5.6 (50.0)	4.9 (43.7)	1,300	1,600	2.65	5.3	0.64 (5.68)	23.7
S34H	PC8x4 ^②	22.0 (195)	21.9 (194)	6.6 (58.4)	4.3 (38.1)	2,400	3,100	6.1	21.2	0.64 (5.68)	5.9
S34H	SC9x3 ^②	11.0 (97.3)	10.9 (96.5)	5.7 (50.4)	4.0 (35.4)	2,700	3,100	5.3	10.6	0.64 (5.68)	5.9
S Series motors with PC34xx Drives											
S21H	PC3403 ^③	0.93 (8.2)	0.91 (8.1)	.49 (4.3)	0.32 (2.8)	12,500	12,500	3.0	6.0	0.042 (0.38)	3.7

① See page 4 for definitions of ratings.
 ② Peak torque ratings are for 5 seconds.
 ③ Peak torque ratings are for 2 seconds.
 ④ Peak torque ratings are for 1 second.

⑤ Peak torque ratings are for .5 second.
 ⑥ Rated speed is provided for operation on 240V ac 3-phase line. Reduce to approximately 85% for 240V ac 1-phase line operation and to 40% for 120V ac 1-phase line operation.

⑦ Includes resolver feedback inertia.
 ⑧ Each system requires one feedback and one motor power cable.
 ⑨ Characteristics shown with drive default parameters limited to 2.5x the motor's continuous rating. Higher peak system performance available. Contact the factory.

SYSTEMS PERFORMANCE DATA

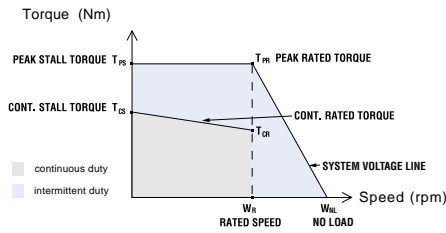

RECOMMENDED MOTOR/DRIVE SYSTEMS, 240V ac, 320V dc bus^① continued

Servo Motor Model ^⑤	Servo Drive Model	Peak Stall Torque T_{PS} Nm (lb.-in.)	Peak Rated Torque T_{PR} ^② Nm (lb.-in.)	Cont. Stall Torque T_{CS} Nm (lb.-in.)	Cont. Rated Torque T_{CR} Nm (lb.-in.)	Rated Speed W_R ^③ rpm	No-Load Speed W_{NL} rpm	Cont. Stall Current I_{CS} A_{RMS}	Current at Peak Torque I_{PS} A_{RMS}	Inertia ^⑦ J kgm ² x 10 ⁻³ (lb.-in.-S ² x 10 ⁻³)	Inductance Line-Line L mH
S22H	PC3403 ^③	1.8 (16.4)	1.8 (16.2)	1.0 (8.8)	0.62 (5.5)	8,500	10,400	2.9	6.0	0.064 (0.56)	5.7
S24G	PC3403 ^③	3.9 (34.9)	3.9 (34.8)	1.6 (14.4)	1.4 (12.7)	3,750	4,900	2.6	6.0	0.100 (0.89)	9.3
S24H	PC3406 ^③	3.9 (34.9)	3.9 (34.4)	1.6 (14.4)	0.55 (4.9)	8,000	9,800	5.1	12.0	0.100 (0.89)	2.2
S31H	PC3403 ^③	3.8 (33.6)	3.7 (32.8)	2.0 (17.7)	1.5 (13.3)	4,300	5,200	3.0	6.0	0.18 (1.58)	10.3
S32G	PC3403 ^③	7.5 (66.0)	7.4 (65.7)	3.9 (34.3)	3.1 (27.4)	2,050	2,600	3.0	6.0	0.34 (2.98)	18
S32H	PC3406 ^③	7.5 (66.0)	7.4 (65.2)	3.9 (34.8)	2.3 (20.3)	4,600	5,300	6.0	12.0	0.34 (2.98)	4.5
S33A	PC3403 ^③	8.9 (78.9)	8.9 (78.5)	4.5 (40.2)	4.6 (40.5)	1,800	2,200	3.0	6.0	0.48 (4.28)	17
S33D	PC3410 ^③	12.9 (114)	12.8 (113)	5.3 (46.9)	3.6 (31.7)	3,700	4,400	7.0	17.5	0.48 (4.28)	4.4
S33G	PC3403 ^③	11.0 (97.4)	11.0 (97.1)	5.3 (47.1)	4.6 (41.1)	1,300	1,800	2.77	6.0	0.48 (4.28)	25.2
S33H	PC3406 ^③	11.0 (97.4)	10.9 (96.8)	5.3 (47.0)	3.7 (33.2)	3,100	3,600	5.6	12.0	0.48 (4.28)	6.3
S34A	PC3403 ^③	9.9 (87.4)	9.8 (86.9)	5.1 (45.1)	4.9 (43.4)	1,700	2,000	3.0	6.0	0.64 (5.68)	14.7
S34G	PC3403 ^③	12.4 (110)	12.4 (109)	6.4 (56.5)	5.0 (44.5)	1,200	1,600	3.0	6.0	0.64 (5.68)	23.7
S34H	PC3406 ^③	12.6 (112)	12.5 (111)	6.4 (56.5)	4.1 (36.3)	2,600	3,100	6.0	12.0	0.64 (5.68)	5.9

① See page 4 for definitions of ratings.

② Peak torque ratings are for 5 seconds.

③ Peak torque ratings are for 2 seconds.

④ Peak torque ratings are for 1 second.

⑤ Peak torque ratings are for .5 second.

⑥ Rated speed is provided for operation on 240V ac 3-phase line. Reduce to approximately 85% for 240V ac 1-phase line operation and to 40% for 120V ac 1-phase line operation.

⑦ Includes resolver feedback inertia.

⑧ Each system requires one feedback and one motor power cable.

⑨ Characteristics shown with drive default parameters limited to 2.5x the motor's continuous rating. Higher peak system performance available. Contact the factory.

RECOMMENDED MOTOR/DRIVE SYSTEMS, 400V ac, 560V dc bus^①

Servo Motor Model ^⑤	Servo Drive Model	Peak Stall Torque T_{PS} ^① Nm (lb.-in.)	Peak Rated Torque T_{PR} ^② Nm (lb.-in.)	Cont. Stall Torque T_{CS} Nm (lb.-in.)	Cont. Rated Torque T_{CR} Nm (lb.-in.)	Rated Speed W_R ^③ rpm	No-Load Speed W_{NL} rpm	Cont. Stall Current I_{CS} A_{RMS}	Current at Peak Torque I_{PS} A_{RMS}	Inertia ^⑦ J kgm ² x 10 ⁻³ (lb.-in.-S ² x 10 ⁻³)	Inductance Line-Line L mH
PMA Series motors with SCE9xx Drives											
PMA42N	SCE9x3	8.2 (72.6)	8.1 (71.7)	4.1 (36.3)	3.2 (28.3)	4,300	5,450	3.7	7.5	0.36 (3.2)	14.3
PMA42P	SCE9x4	12.4 (110)	12.3 (109)	4.1 (36.3)	3.0 (26.6)	5,100	6,950	4.7	15.0	0.36 (3.2)	8.9
PMA43N	SCE9x3	12.2 (108)	12.1 (107)	6.1 (54.0)	5.3 (46.9)	2,800	3,600	3.7	7.5	0.52 (4.6)	20.0
PMA43P	SCE9x4	18.8 (166)	18.7 (165)	6.1 (54.0)	5.1 (45.1)	3,300	4,500	4.6	15.0	0.52 (4.6)	13.0
PMA43Q	SCE9x4	12.5 (111)	12.4 (110)	6.1 (54.0)	4.0 (35.4)	6,000	7,100	7.2	15.0	0.52 (4.6)	5.3
PMA44N	SCE9x3	16.9 (150)	16.8 (149)	8.2 (72.6)	7.3 (64.6)	2,100	2,650	3.6	7.5	0.68 (6.0)	27.0
PMA44Q	SCE9x4	16.9 (150)	16.7 (148)	8.2 (72.6)	4.9 (43.4)	4,400	5,250	7.2	15.0	0.68 (6.0)	7.1
PMA45N	SCE9x3	21.0 (186)	20.9 (185)	10.2 (90.3)	9.5 (84.0)	1,600	2,100	3.6	7.5	0.84 (7.4)	33.0
PMA45Q	SCE9x4	21.3 (189)	21.1 (187)	10.2 (90.3)	7.9 (69.9)	3,400	4,150	7.1	15.0	0.84 (7.4)	8.7
PMA53Q	SCE9x4	20.7 (183)	20.6 (182)	10.5 (92.9)	8.2 (72.6)	2,900	3,900	6.8	15.0	1.92 (17.0)	15.0
PMA53R	SCE9x5	21.6 (191)	21.5 (190)	10.5 (92.9)	7.2 (63.7)	4,200	5,600	9.7	22.5	1.92 (17.0)	7.2
PMA54Q	SCE9x4	25.9 (229)	25.8 (228)	13.5 (120)	11.4 (101)	2,400	3,150	7.1	15.0	2.49 (22.0)	16.0
PMA54R	SCE9x5	26.0 (230)	25.8 (228)	13.5 (150)	10.0 (88.5)	3,750	4,800	10.6	22.5	2.49 (22.0)	7.1
PMA55Q	SCE9x4	32.6 (289)	32.5 (288)	17.0 (151)	14.8 (131)	1,900	2,500	7.1	15.0	3.06 (27.1)	20.0
PMA55R	SCE9x5	32.8 (290)	32.6 (289)	17.0 (151)	13.7 (121)	3,000	3,800	10.6	22.5	3.06 (27.1)	8.8
PMA57R	SCE9x5	45.9 (406)	45.7 (404)	22.0 (195)	19.0 (168)	2,100	2,700	9.8	22.5	4.21 (37.3)	12.5
PMA65R	SCE9x5	55.9 (495)	55.7 (493)	30.0 (266)	25.0 (221)	1,600	2,250	11.3	22.5	7.9 (70.0)	20.0
PMA65S	SCE9x6	46.1 (408)	45.6 (404)	30.0 (266)	19.0 (169)	3,300	4,200	20.9	33.7	7.9 (70.0)	5.9
PMA66R	SCE9x5	67.1 (594)	66.9 (592)	36.0 (319)	31.4 (278)	1,350	1,850	11.3	22.5	9.4 (83.3)	24.0
PMA66S	SCE9x6	55.8 (494)	55.4 (490)	36.0 (319)	22.3 (197)	2,750	3,500	20.7	33.7	9.4 (83.0)	7.0
PMA67S	SCE9x6	65.1 (576)	64.7 (573)	42.0 (372)	32.8 (283)	2,350	2,950	20.7	33.7	10.9 (96.5)	8.2
PMA69S	SCE9x6	84.1 (744)	83.7 (741)	54.0 (478)	43.8 (388)	1,800	2,300	20.6	33.7	13.9 (123)	10.4
S Series motors with SCE9xx Drives											
S33A	SCE9x3	11.1 (98.4)	11.0 (97.4)	5.3 (47.0)	3.9 (34.5)	3,300	3,900	3.5	7.5	0.48 (4.28)	17.0
S34A	SCE9x3	12.4 (110)	12.3 (109)	6.4 (56.5)	4.3 (37.9)	3,000	3,500	3.8	7.5	0.64 (5.68)	14.7

① See page 4 for definitions of ratings.

② Peak torque ratings are for 5 seconds.

③ Rated speed is provided for operation on 480V ac 3-phase line.

④ Includes resolver feedback inertia.

⑤ Each system requires one feedback and one motor power cable.

SYSTEMS PERFORMANCE DATA

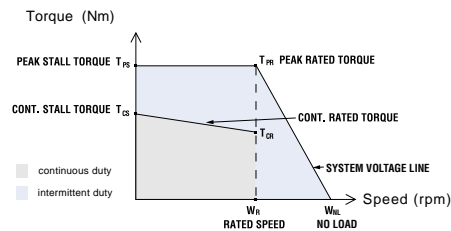

RECOMMENDED MOTOR/DRIVE SYSTEMS, 480V ac^①, 640V dc bus

Servo Motor Model ^⑤	Servo Drive Model	Peak Stall Torque T_{PS} ^② Nm (lb.-in.)	Peak Rated Torque T_{PR} ^② Nm (lb.-in.)	Cont. Stall Torque T_{CS} Nm (lb.-in.)	Cont. Rated Torque T_{CR} Nm (lb.-in.)	Rated Speed W_R ^③ rpm	No-Load Speed W_{NL} rpm	Cont. Stall Current I_{CS} A_{RMS}	Current at Peak Torque I_{PS} A_{RMS}	Inertia ^④ J kgm ² x 10 ⁻³ (lb.-in.-S ² x 10 ⁻³)	Inductance Line-Line L mH
PMA Series motors with SCE9xx Drives											
PMA42N	SCE9x3	8.2 (72.6)	8.1 (71.7)	4.1 (36.3)	3.2 (28.3)	4,300	5,450	3.7	7.5	0.36 (3.2)	14.3
PMA42P	SCE9x4	12.4 (110)	12.3 (109)	4.1 (36.3)	3.0 (26.6)	5,100	6,950	4.7	15.0	0.36 (3.2)	8.9
PMA43N	SCE9x3	12.2 (108)	12.1 (107)	6.1 (54.0)	5.3 (46.9)	2,800	3,600	3.7	7.5	0.52 (4.6)	20.0
PMA43P	SCE9x4	18.8 (166)	18.7 (165)	6.1 (54.0)	5.1 (45.1)	3,300	4,500	4.6	15.0	0.52 (4.6)	13.0
PMA43Q	SCE9x4	12.5 (111)	12.4 (110)	6.1 (54.0)	4.0 (35.4)	6,000	7,100	7.2	15.0	0.52 (4.6)	5.3
PMA44N	SCE9x3	16.9 (150)	16.8 (149)	8.2 (72.6)	7.3 (64.6)	2,100	2,650	3.6	7.5	0.68 (6.0)	27.0
PMA44Q	SCE9x4	16.9 (150)	16.7 (148)	8.2 (72.6)	4.9 (43.4)	4,400	5,250	7.2	15.0	0.68 (6.0)	7.1
PMA45N	SCE9x3	21.0 (186)	20.9 (185)	10.2 (90.3)	9.5 (84.0)	1,600	2,100	3.6	7.5	0.84 (7.4)	33.0
PMA45Q	SCE9x4	21.3 (189)	21.1 (187)	10.2 (90.3)	7.9 (69.9)	3,400	4,150	7.1	15.0	0.84 (7.4)	8.7
PMA53Q	SCE9x4	20.7 (183)	20.6 (182)	10.5 (92.9)	8.2 (72.6)	2,900	3,900	6.8	15.0	1.92 (17.0)	15.0
PMA53R	SCE9x5	21.6 (191)	21.5 (190)	10.5 (92.9)	7.2 (63.7)	4,200	5,600	9.7	22.5	1.92 (17.0)	7.2
PMA54Q	SCE9x4	25.9 (229)	25.8 (228)	13.5 (120)	11.4 (101)	2,400	3,150	7.1	15.0	2.49 (22.0)	16.0
PMA54R	SCE9x5	26.0 (230)	25.8 (228)	13.5 (150)	10.0 (88.5)	3,750	4,800	10.6	22.5	2.49 (22.0)	7.1
PMA55Q	SCE9x4	32.6 (289)	32.5 (288)	17.0 (151)	14.8 (131)	1,900	2,500	7.1	15.0	3.06 (27.1)	20.0
PMA55R	SCE9x5	32.8 (290)	32.6 (289)	17.0 (151)	13.7 (121)	3,000	3,800	10.6	22.5	3.06 (27.1)	8.8
PMA57R	SCE9x5	45.9 (406)	45.7 (404)	22.0 (195)	19.0 (168)	2,100	2,700	9.8	22.5	4.21 (37.3)	12.5
PMA65R	SCE9x5	55.9 (495)	55.7 (493)	30.0 (266)	25.0 (221)	1,600	2,250	11.3	22.5	7.9 (70.0)	20.0
PMA65S	SCE9x6	46.1 (408)	45.6 (404)	30.0 (266)	19.0 (169)	3,300	4,200	20.9	33.7	7.9 (70.0)	5.9
PMA66R	SCE9x5	67.1 (594)	66.9 (592)	36.0 (319)	31.4 (278)	1,350	1,850	11.3	22.5	9.4 (83.3)	24.0
PMA66S	SCE9x6	55.8 (494)	55.4 (490)	36.0 (319)	22.3 (197)	2,750	3,500	20.7	33.7	9.4 (83.0)	7.0
PMA67S	SCE9x6	65.1 (576)	64.7 (573)	42.0 (372)	32.8 (283)	2,350	2,950	20.7	33.7	10.9 (96.5)	8.2
PMA69S	SCE9x6	84.1 (744)	83.7 (741)	54.0 (478)	43.8 (388)	1,800	2,300	20.6	33.7	13.9 (123)	10.4
S Series motors with SCE9xx Drives											
S33A	SCE9x3	11.1 (98.4)	11.0 (97.4)	5.3 (47.0)	3.9 (34.5)	3,300	3,900	3.5	7.5	0.48 (4.28)	17.0
S34A	SCE9x3	12.4 (110)	12.3 (109)	6.4 (56.5)	4.3 (37.9)	3,000	3,500	3.8	7.5	0.64 (5.68)	14.7

① See page 4 for definitions of ratings.
 ② Peak torque ratings are for 5 seconds.
 ③ Rated speed is provided for operation on 480V ac 3-phase line.

④ Includes resolver feedback inertia.
 ⑤ Each system requires one feedback and one motor power cable.

PMA SERIES BRUSHLESS SERVO MOTORS

THE MOST RUGGED, COMPREHENSIVE LINE OF COST-EFFECTIVE SERVOMOTORS

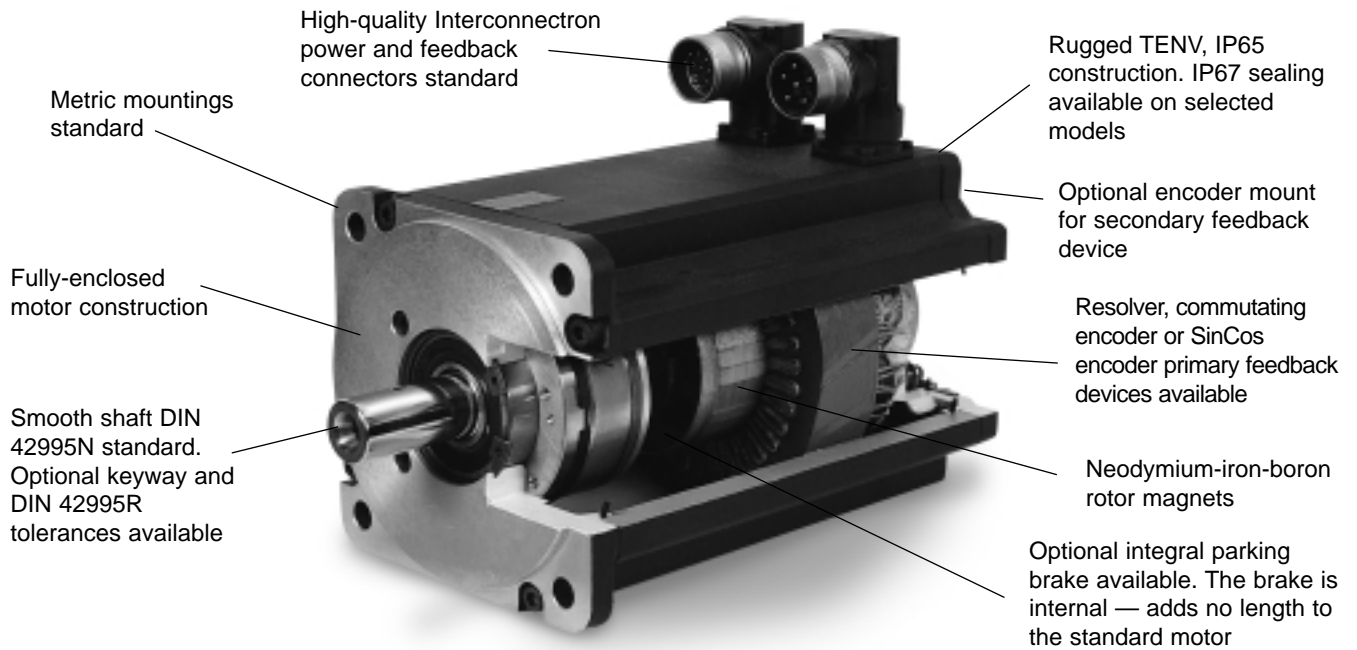

P M A 4 2 R - 0 0 1 0^②0^③ - 0 0

Pacific Scientific

Brushless Servomotors

Product Series

Frame Size

- 1 = 55mm motor body square
- 2 = 70mm motor body square
- 4 = 115mm motor body square
- 5 = 142mm motor body square
- 6 = 190mm motor body square

Stack Length

- 1-9 = Stack length multiple

Winding

Winding Designator:		Nominal Stall Current, A _{RMS}
240V ac max.	240-480V ac	
A	L	1.3
B	M	2.7
C	N	3.8
D	P	5.4
E	Q	7.4
F	R	11.0
G	S	22.0

Customization Code, Factory assigned

- 00 = Standard Motor
- 01 = Indicates Oil Seal^⑩

Sensor

- 00 = Resolver
- 12 = Digital Encoder with commutation, 1024 ppr^⑧
- 14 = Digital Encoder with commutation, 2048 ppr^⑧
- 20 = SinCos Encoder (Stegmann SNS50/60)^⑨
- 30 = Resolver with Encoder Mount^⑦

Connector^①

- 1 = 6PP, 12PSO^⑤
- = 6PP, 17PSO^⑤

Brake^⑥

- 0 = No Brake
- 1 = 24V Brake

Shaft

- 0 = Smooth Shaft, DIN42955 N
- 1 = Closed Keyway, Key Fitted, DIN42995 N (Not available PMA1)
- 3 = Smooth Shaft, DIN42955 R
- 4 = Closed Keyway, Key Fitted, DIN42995 R (Not available PMA1)

① Right-Angle type standard; 6-Pin Power = 6PP etc.; 12-Pin Sensor, 0deg. Code.

② Encoder Mount: Motor prepared to mount external encoder (ROD426).

③ Standard thermal sensor: Thermistor.

④ Mating Connectors available separately. Contact Pacific Scientific.

⑤ With commutating encoder option, standard feedback connector is 17-pin. See page 32.

⑥ Oil seal available on PMA1, PMA2 and PMA4 models only (PMA4 requires special endbell with seal option).

⑦ For more details on encoder mounting provisions, contact Pacific Scientific.

⑧ Commutating encoder option available on PMA2, PMA4, PMA5 and PMA6 models only.

⑨ Sin Cos encoder option available on PMA4, PMA5 and PMA6 models only.

⑩ PMA2 models accept *either* oil seal option *or* brake option — not both.

PMA1 SERIES MOTOR



- 6-pole synchronous servomotors
- Neodymium-iron-boron magnets for maximum torque
- 240V ac, 320V dc bus maximum operation
- Available with integral brake
- IP65 or optional IP67 protection
- Anti-cog stator design
- High-quality Interconnectron connectors
- Rated speeds to 9,000 RPM

The PMA1 Series Motors cover a continuous torque range from 0.21 to 0.6 Nm. These compact motors are well-suited for speed, and position control applications that require maximum performance in minimum space.

PMA SERIES

RATINGS AND CHARACTERISTICS

Motor parameters and winding data. See system data beginning on page 4 for typical torque/speed performance.

PARAMETER	SYMBOL	UNITS	PMA11	PMA12	PMA13
Continuous stall torque ^{① ②}	T _{CS}	Nm (lb.-in.)	0.26 (2.3)	0.6 (5.3)	0.9 (8.0)
Peak torque ^{③ ④}	T _{PK}	Nm (lb.-in.)	1.4 (12.4)	2.9 (25.6)	4.3 (38.0)
Inertia ^{⑤ ⑥}	J _M	kgm ² × 10 ⁻³ (lb.-in.-sec ² × 10 ⁻³)	0.012 (0.102)	0.019 (0.164)	0.026 (0.226)
Static friction (max.)	T _f	Nm (lb.-in.)	0.008 (0.071)	0.012 (0.106)	0.018 (0.160)
Viscous damping coefficient	K _{DV}	Nm/kRPM (lb.-in./kRPM)	0.001 (0.009)	0.002 (0.018)	0.003 (0.027)
Thermal resistance	R _{TH}	deg. C/Watt	3.1	2.0	1.6
Thermal time constant	τ _{TH}	min.	10.0	13.0	16.0
Weight (motor only)	W	kg (lbs.)	1.2 (2.6)	1.5 (3.3)	1.9 (4.2)
WINDING DATA			A	A	B
Torque constant (RMS)	K _T	Nm/A _{RMS} (lb.-in./A _{RMS})	0.27 (2.38)	0.32 (2.85)	0.33 (2.90)
Voltage constant (RMS) (I-n)	K _E	V _{RMS} /rad/sec (V _{RMS} /kRPM)	0.16 (17.2)	0.20 (20.6)	0.20 (21.0)
Continuous stall current ^{① ②}	I _{CS}	A _{RMS}	0.96	1.88	2.73
Current at peak torque ^③	I _{PK}	A _{RMS}	5.3	9.4	13.8
Resistance (line-to-line)	R _C	Ohms	16.3	6.8	3.9
Inductance (line-to-line)	L	mH	7.1	4.3	2.7
Typical Rated Speed @ 240V ac, 320V dc bus	W _R	RPM	6,600	8,500	9,000
Typical Rated Torque @ 240V ac, 320V dc bus	T _{CR}	Nm (lb.-in.)	0.22 (1.9)	0.48 (4.2)	0.60 (5.3)

Metric Mount Shown

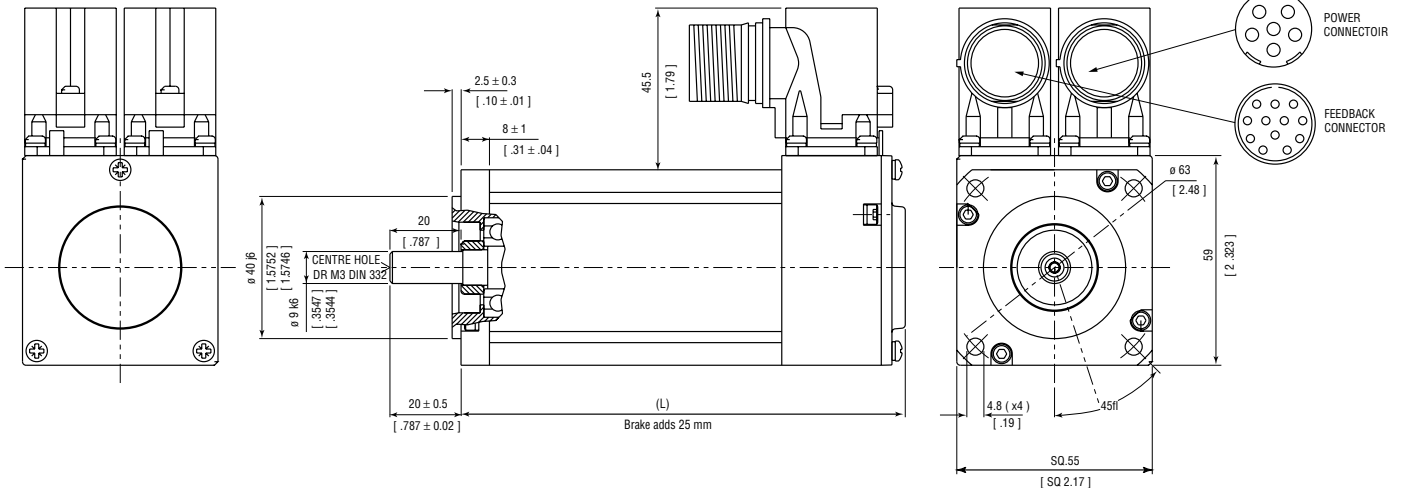

Note: All values at 25°C unless otherwise noted.

- ① Motor operated at rated winding temperature rise of Δt = 100°C above ambient at 25°C ambient. Ratings result of average rating between free air and cold plate mounting. Equivalent to mounting to a 10" x 10" x 1/4" aluminum heat sink.
- ② All tests performed with sinusoidal commutation.
- ③ Theoretical motor maximum.
- ④ Caution: For peak torques or peak currents greater than 4x the continuous rating, consult the factory for thermal considerations.
- ⑤ Add parking brake, if applicable, for total inertia.
- ⑥ Motor with resolver feedback.

Model	PMA13	PMA12	PMA11
L	175 (6.890)	150 (5.906)	125 (4.921)

mm (in.)
Note: Brake option adds 25 mm (.98") to total length.

PMA2 SERIES MOTOR



- 6-pole synchronous servomotors
- Neodymium-iron-boron magnets for maximum torque
- 240V ac, 320V dc bus maximum operation
- Available with integral brake
- IP65 or optional IP67 protection
- Anti-cog stator design
- High-quality Interconnectron connectors
- Rated speeds to 7,400 RPM

The PMA2 Series motors cover a continuous torque range from 0.5 to 2.6 Nm. These compact motors are well-suited for speed and position control applications requiring maximum performance in minimum space. The PMA2 Series is available with a commutating encoder, in addition to the standard resolver primary feedback, allowing for integration with other control schemes.

RATINGS AND CHARACTERISTICS

Motor parameters and winding data. See system data beginning on page 4 for typical torque/speed performance.

PARAMETER	SYMBOL	UNITS	PMA21	PMA22	PMA23			PMA24	
Continuous stall torque ^{① ② ⑦}	T_{CS}	Nm (lb.-in.)	0.63 (5.6)	1.3 (11.5)	2 (17.7)			2.6 (23.0)	
Peak torque ^{③ ④}	T_{PK}	Nm (lb.-in.)	2.3 (20.4)	4.7 (41.6)	7.2 (63.7)			9.6 (85.0)	
Inertia ^⑤	J_M	$kgm^2 \times 10^{-3}$ (lb.-in.-sec ² $\times 10^{-3}$)	0.022 (0.19)	0.038 (0.34)	0.055 (0.49)			0.072 (0.64)	
Static friction (max.)	T_f	Nm (lb.-in.)	0.016 (0.14)	0.033 (0.29)	0.050 (0.44)			0.065 (0.58)	
Viscous damping coefficient	K_{DV}	Nm/kRPM (lb.-in./KRPM)	0.003 (0.03)	0.006 (0.05)	0.009 (0.08)			0.012 (0.11)	
Thermal resistance	R_{TH}	deg. C/Watt	1.83	1.41	1.13			0.89	
Thermal time constant	τ_{TH}	min.	13.0	15.0	18.0			20.0	
Weight (motor only)	W	kg (lbs.)	1.7 (3.7)	2.3 (5.0)	2.9 (6.4)			3.5 (7.7)	
WINDING DATA			B	B	B	C	D	C	D
Torque constant (RMS)	K_T	Nm/A _{RMS} (lb.-in./A _{RMS})	0.37 (3.3)	0.49 (4.3)	0.74 (6.5)	0.59 (5.2)	0.4 (3.5)	0.79 (7.0)	0.5 (4.41)
Voltage constant (RMS) (I-n)	K_E	$V_{RMS}/rad/sec$ ($V_{RMS}/kRPM$)	0.23 (24.0)	0.30 (31.2)	0.45 (47.4)	0.36 (37.9)	0.24 (25.4)	0.49 (50.9)	0.31 (31.9)
Continuous stall current ^②	I_{CS}	A _{RMS}	1.72	2.65	2.7	3.4	5.0	3.3	5.3
Current at peak torque ^④	I_{PK}	A _{RMS}	6.88	10.6	10.8	13.6	20.0	13.2	21.2
Resistance (line-to-line)	R_c	Ohms	8.8	4.81	6.1	3.8	1.7	4.6	1.9
Inductance (line-to-line)	L	mH	10.5	7.4	10.6	6.8	3.0	8.9	3.5
Typical Rated Speed @ 240V ac, 320V dc bus	W_R	RPM	6,050	4,650	3,600	4,200	6,400	3,000	4,950
Typical Rated Torque @ 240V ac, 320V dc bus	T_{CR}	Nm (lb.-in.)	0.5 (4.4)	1.06 (9.4)	1.7 (14.6)	1.6 (14.2)	1.4 (12.4)	2.2 (19.5)	2.2 (19.5)

Metric Mount Shown

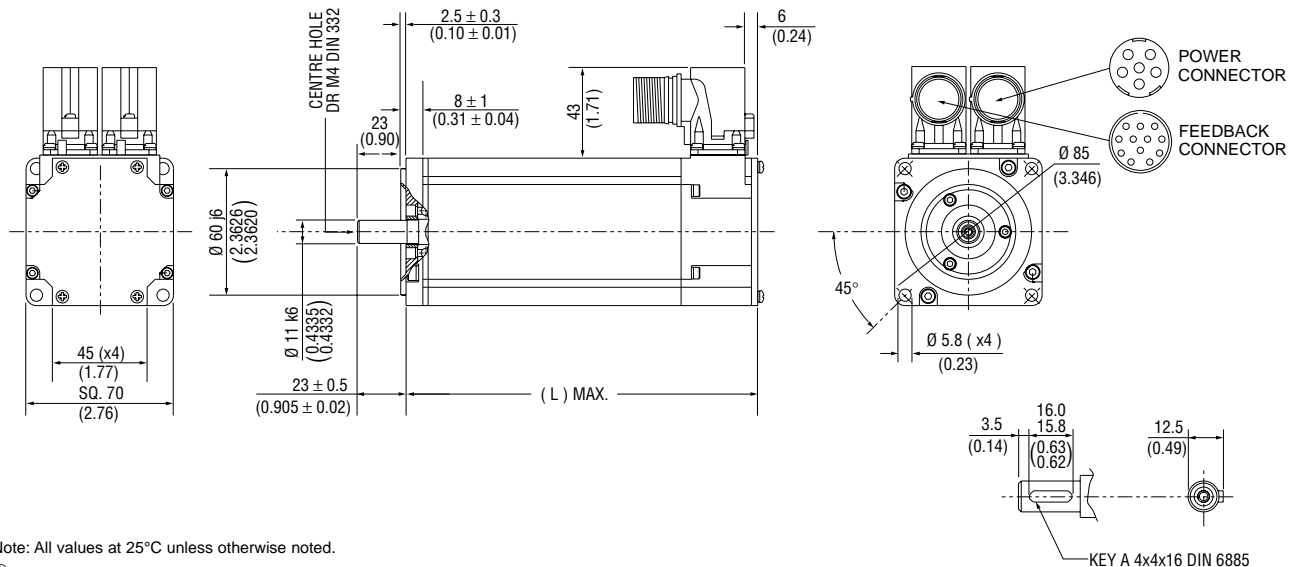

Note: All values at 25°C unless otherwise noted.

- ① Motor operated at rated winding temperature rise of $\Delta t = 100^\circ C$ above ambient at 25°C ambient. Ratings result of average rating between free air and cold plate mounting. Equivalent to mounting to a 10" x 10" x 1/4" aluminum heat sink.
- ② All tests performed with sinusoidal commutation.
- ③ Theoretical motor maximum.
- ④ Caution: For peak torques or peak currents greater than 4x the continuous rating, consult the factory for thermal considerations.
- ⑤ Add parking brake, if applicable, for total inertia.
- ⑥ Motor with resolver feedback.
- ⑦ Commutating encoder option may reduce continuous torque ratings by up to 10%. Contact factory for details.

CUSTOMER KEY OPTION

Motor	PMA21	PMA22	PMA23	PMA24
L Max	143 (5.6)	168 (6.6)	193 (7.6)	218 (8.6)

mm (in.)
Note: Commutating encoder option adds 15 mm (0.59") to total length.

PMA4 SERIES MOTOR



- 6-pole synchronous servomotors
- Neodymium-iron-boron magnets for maximum torque
- 240V or 480V ac operation
- Available with integral brake
- IP65 or optional IP67 protection
- Anti-cog stator design
- High-quality Interconnectron connectors
- Rated speeds to 6,800 RPM

The PMA4 Series motors cover a continuous torque range from 2.6 to 10.2 Nm. These rugged motors are well-suited for speed and position control applications requiring maximum performance at maximum value. The PMA4 Series is available with commutating encoder or SinCos encoder feedback devices, in addition to the standard resolver primary feedback, allowing for integration with other control schemes.

PMA SERIES

RATINGS AND CHARACTERISTICS

Motor parameters and winding data. See system data beginning on page 4 for typical torque/speed performance.

PARAMETER	SYMBOL	UNITS	PMA42				PMA43				PMA44				PMA45			
Continuous stall torque ^{①②}	T_{CS}	Nm (lb.-in.)	4.1 (36.3)				6.1 (54.0)				8.2 (72.6)				10.2 (90.3)			
Peak torque ^{③④}	T_{PK}	Nm (lb.-in.)	14.6 (129)				21.7 (192)				29.4 (260)				36.8 (326)			
Inertia ^⑤	J_M	kgm ² × 10 ⁻³ (lb.-in.-sec ² × 10 ⁻³)	0.36 (3.2)				0.52 (4.6)				0.68 (6.0)				0.84 (7.4)			
Static friction (max.)	T_f	Nm (lb.-in.)	0.11 (1.0)				0.15 (1.3)				0.21 (1.9)				0.26 (2.3)			
Viscous damping coefficient	K_{DV}	Nm/kRPM (lb.-in./KRPMM)	0.03 (0.27)				0.05 (0.44)				0.06 (0.53)				0.08 (0.71)			
Thermal resistance	R_{TH}	deg. C/Watt	0.68				0.59				0.51				0.45			
Thermal time constant	τ_{TH}	min.	25.0				30.0				35.0				40.0			
Weight (motor only)	W	kg (lbs.)	6.2 (13.6)				7.6 (16.7)				9.0 (20.0)				10.4 (22.9)			
WINDING DATA																		
Torque constant (RMS)	K_T	Nm/Arms (lb.-in./A _{RMS})	M	N	P	Q	N	P	Q	R	N	P	Q	R	N	Q	R	
Voltage constant (RMS) (l-n)	K_E	Vrms/rad/sec (V _{RMS} /KRPMM)	1.48 (13.1)	1.11 (9.8)	0.87 (7.7)	0.63 (5.6)	1.67 (14.8)	1.34 (11.9)	0.85 (7.5)	.61 (5.4)	2.26 (20.0)	1.54 (13.6)	1.15 (10.2)	0.82 (7.3)	2.85 (25.2)	1.46 (12.9)	1.04 (9.2)	
Continuous stall current ^{①②}	I_{CS}	A _{RMS}	2.8	3.7	4.7	6.5	3.7	4.6	7.2	10.1	3.6	5.4	7.2	10.1	3.6	7.1	10.0	
Current at peak torque ^④	I_{PK}	A _{RMS}	11.2	14.8	18.8	26.0	14.8	18.4	28.8	40.4	14.4	21.6	28.8	40.4	14.4	28.4	40.0	
Resistance (line to line)	R_C	Ohms	9.0	5.1	3.2	1.65	6.0	3.9	1.54	0.79	7.1	3.3	1.8	0.92	8.2	2.1	1.1	
Inductance (line to line)	L	mH	26.0	14.3	8.9	4.7	20.0	13.0	5.3	2.7	27.0	12.4	7.1	3.6	33.0	8.7	4.4	
Typical Rated Speed @ 240V ac, 320V dc bus	W_R	RPM	1,600	1,950	2,950	3,800	1,250	1,850	3,000	4,700	850	1,750	2,100	3,450	600	1,650	2,700	
Typical Rated Torque @ 240V ac, 320V dc bus	T_{CR}	Nm (lb.-in.)	3.9 (34.5)	3.8 (33.6)	3.6 (31.9)	34.0 (30.1)	5.8 (51.3)	5.6 (49.6)	5.2 (46.0)	4.5 (39.8)	7.9 (70.0)	7.5 (66.4)	7.3 (64.4)	6.7 (59.3)	9.9 (87.6)	9.4 (83.2)	8.9 (78.8)	
Typical Rated Speed @ 400V ac, 580V dc bus	W_R	RPM	N/A	4,300	5,100	N/A	2,800	3,300	6,000	N/A	2,100	N/A	4,400	N/A	1,600	3,400	N/A	
Typical Rated Torque @ 400V ac, 580V dc bus	T_{CR}	Nm (lb.-in.)	N/A	3.2 (28.3)	3.0 (26.6)	N/A	5.3 (46.9)	5.1 (45.1)	4.0 (35.4)	N/A	7.3 (64.6)	N/A	4.9 (43.4)	N/A	9.5 (84)	7.9 (69.9)	N/A	
Typical Rated Speed @ 480V ac, 640V dc bus	W_R	RPM	N/A	5,550	5,950	N/A	3,350	3,850	6,800	N/A	2,400	N/A	5,100	N/A	1,900	4,000	N/A	
Typical Rated Torque @ 480V ac, 640V dc bus	T_{CR}	Nm (lb.-in.)	N/A	2.8 (24.8)	2.6 (23)	N/A	5.1 (45.1)	4.9 (43.4)	3.6 (31.9)	N/A	7.2 (63.7)	N/A	4.4 (38.9)	N/A	9.3 (82.3)	7.3 (64.6)	N/A	

Metric Mount Shown

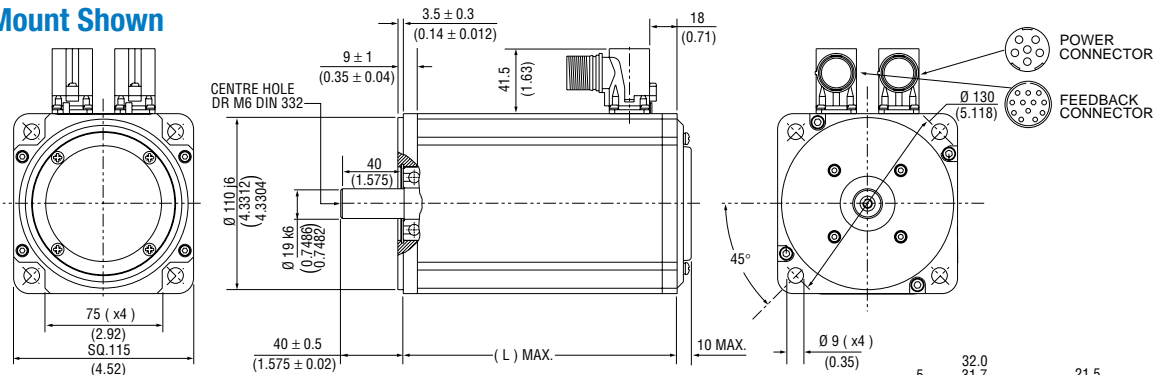

Note: All values at 25°C unless otherwise noted.

- ① Motor operated at rated winding temperature rise of $\Delta t = 100^\circ\text{C}$ above ambient at 25°C ambient. Ratings result of average rating between free air and cold plate mounting. Equivalent to mounting to a 10" x 10" x 1/4" aluminum heat sink.
- ② All tests performed with sinusoidal commutation.
- ③ Theoretical motor maximum.
- ④ Caution: For peak torques or peak currents greater than 4x the continuous rating, consult the factory for thermal considerations.
- ⑤ Add parking brake, if applicable, for total inertia.
- ⑥ Motor with resolver feedback.
- ⑦ Commutating encoder option may reduce continuous torque ratings by up to 10%. Contact factory for details.

Motor	PMA42	PMA43	PMA44	PMA45
L Max	185 (7.3)	210 (8.3)	235 (9.2)	260 (10.2)

m (in.)
Note: SinCos encoder option adds 31 mm (1.22") to total length.

PMA5 SERIES MOTOR



- 6-pole synchronous servomotors
- Neodymium-iron-boron magnets for maximum torque
- 240V or 480V ac operation
- Available with integral brake
- IP65 protection
- Anti-cog stator design
- High-quality Interconnectron connectors
- Rated speeds to 4,750 RPM

The PMA5 Series motors cover a continuous torque range from 6.8 to 22 Nm. These rugged motors are well-suited for speed and position control applications requiring maximum performance at maximum value. The PMA5 Series is available with commutating encoder or SinCos encoder feedback devices, in addition to the standard resolver primary feedback, allowing for integration with other control schemes.

RATINGS AND CHARACTERISTICS

Motor parameters and winding data. See system data beginning on page 4 for typical torque/speed performance.

PARAMETER	SYMBOL	UNITS	PMA53	PMA54	PMA55	PMA57					
Continuous stall torque ^{① ② ③}	T _{CS}	Nm (lb.-in.)	10.5 (92.9)	13.5 (120)	17.0 (151)	22.0 (195)					
Peak torque ^{③ ④}	T _{PK}	Nm (lb.-in.)	31.0 (274)	41.0 (363)	51.5 (456)	69.0 (611)					
Inertia ^{⑤ ⑥}	J _M	kgm ² x10 ⁻³ (lb.-in.-sec ² x10 ⁻³)	1.92 (17)	2.49 (22)	3.06 (27.1)	4.21 (37.3)					
Static friction (max.)	T _f	Nm (lb.-in.)	0.26 (2.3)	0.34 (3.0)	0.43 (3.8)	0.57 (5.0)					
Viscous damping coefficient	K _{GV}	Nm/kRPM (lb.-in./kRPM)	0.08 (0.71)	0.11 (0.97)	0.14 (1.24)	0.18 (1.59)					
Thermal resistance	R _{TH}	deg. C/Watt	0.55	0.53	0.47	0.45					
Thermal time constant	τ _{TH}	min.	35	40.0	45.0	55.0					
Weight (motor only)	W	kg (lbs.)	11 (24.2)	13.0 (28.6)	15.0 (33.0)	19.0 (41.9)					
WINDING DATA											
Torque constant (RMS)	K _T	Nm/A _{RMS} (lb.-in./A _{RMS})	1.55 (13.7)	1.08 (9.6)	1.9 (16.8)	1.27 (11.3)	2.4 (21.3)	1.6 (14.2)	0.8 (7.1)	2.26 (20)	1.13 (10)
Voltage constant (RMS) (I-n)	K _E	V _{RMS} /rad/sec (V _{RMS} /kRPM)	0.95 (99.3)	0.66 (69.2)	1.16 (122)	0.78 (81.5)	1.47 (154)	0.98 (103)	0.49 (51.3)	1.38 (145)	0.69 (72.5)
Continuous stall current ^{① ②}	I _{CS}	A _{RMS}	6.8	9.7	7.1	10.6	7.1	10.6	21.3	9.8	19.5
Current at peak torque ^④	I _{PK}	A _{RMS}	27.2	38.8	28.4	42.4	28.4	42.4	85.2	39.2	78.0
Resistance (line-to-line)	R _C	Ohms	1.9	0.92	1.8	0.8	2.1	0.9	0.2	1.1	0.3
Inductance (line-to-line)	L	mH	15.0	7.2	16.0	7.1	20.0	8.8	2.2	12.5	3.1
Typical Rated Speed @ 240V ac, 320V dc bus	W _R	RPM	1,300	2,350	1,200	2,100	900	1,650	3,450	1,150	2,450
Typical Rated Torque @ 240V ac, 320V dc bus	T _{GR}	Nm (lb.-in.)	9.6 (85.0)	8.8 (77.9)	12.4 (110)	11.6 (102.7)	16.0 (142)	15.2 (134.5)	13.1 (115.9)	20.5 (181.4)	18.4 (162.9)
Typical Rated Speed @ 400V ac, 560V dc bus	W _R	RPM	2,900	4,200	2,400	3,750	1,900	3,000	N/A	2,100	N/A
Typical Rated Torque @ 400V ac, 560V dc bus	T _{GR}	Nm (lb.-in.)	8.2 (72.6)	7.2 (63.7)	11.4 (101)	10.0 (88.5)	14.8 (131)	13.7 (121)	N/A	19.0 (168)	N/A
Typical Rated Speed @ 480V ac, 640V dc bus	W _R	RPM	3,350	4,750	2,800	4,300	2,200	3,400	N/A	2,400	N/A
Typical Rated Torque @ 480V ac, 640V dc bus	T _{GR}	Nm (lb.-in.)	7.8 (69)	6.8 (60)	11.0 (97.4)	9.7 (85.8)	14.5 (128.3)	13.3 (109)	N/A	18.6 (164.6)	N/A

Metric Mount Shown

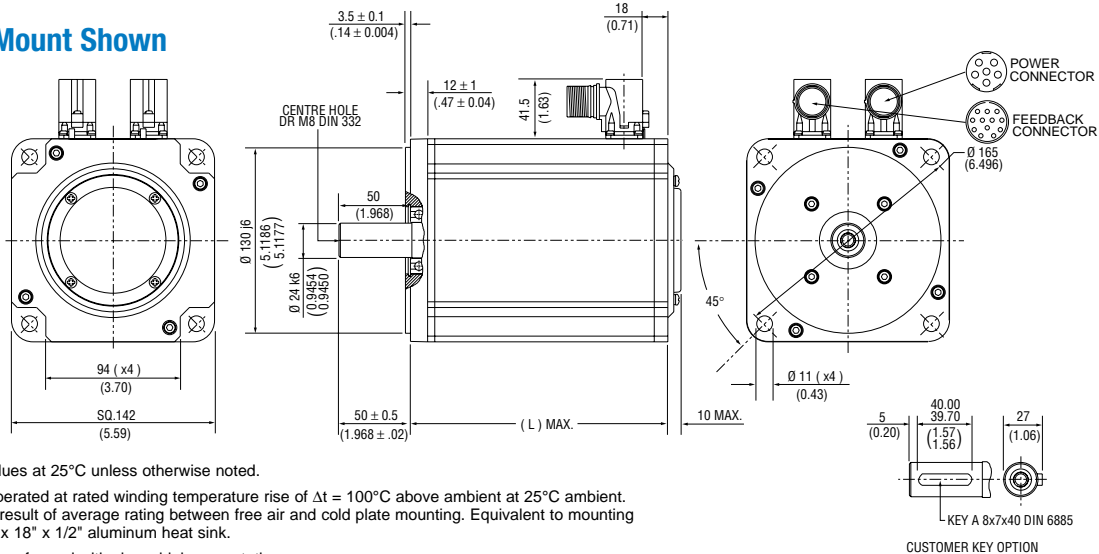

Note: All values at 25°C unless otherwise noted.

- ① Motor operated at rated winding temperature rise of Δt = 100°C above ambient at 25°C ambient. Ratings result of average rating between free air and cold plate mounting. Equivalent to mounting to a 18" x 18" x 1/2" aluminum heat sink.
- ② All tests performed with sinusoidal commutation.
- ③ Theoretical motor maximum.
- ④ Caution: For peak torques or peak currents greater than 4x the continuous rating, consult the factory for thermal considerations.
- ⑤ Add parking brake, if applicable, for total inertia.
- ⑥ Motor with resolver feedback.
- ⑦ Commutating encoder option may reduce continuous torque ratings by up to 10%. Contact factory for details.

Motor	PMA53	PMA54	PMA55	PMA57
L Max	205 (8.1)	230 (9.0)	255 (10.0)	305 (12.0)

mm (in.)
Note: SinCos encoder option adds 14 mm (.55") to total length.

PMB SERIES BRUSHLESS SERVO MOTORS

**COST-EFFECTIVE, HIGH PERFORMANCE FOR HIGHER VOLUME
LIGHT-INDUSTRIAL APPLICATIONS**

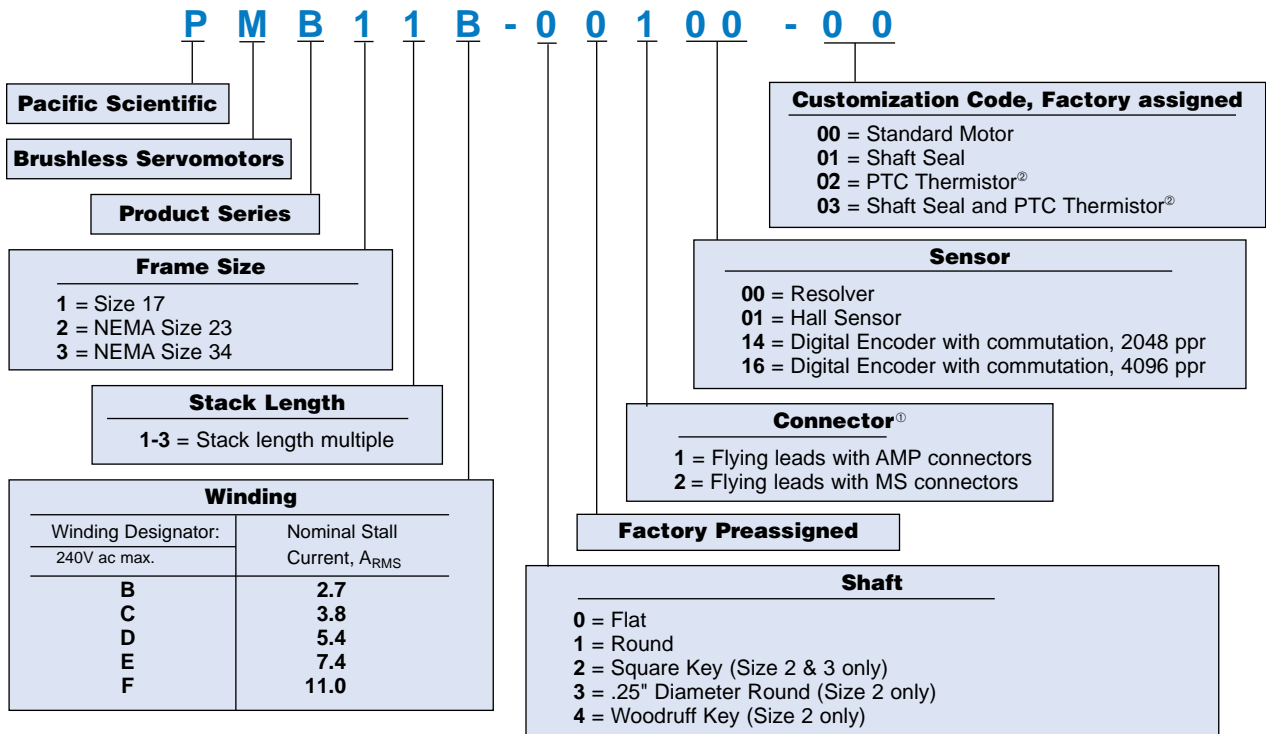
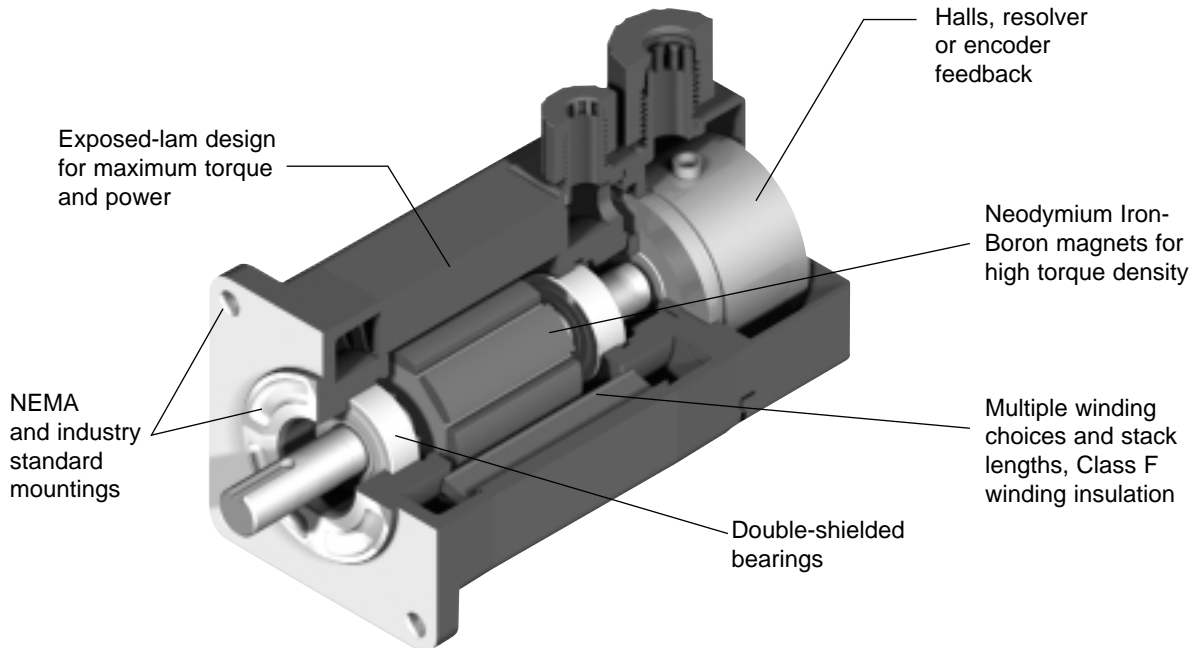

① Mating connectors not provided.

② Thermistor not available on PMB1 motors with resolver feedback.

PMB2 SERIES MOTOR



- 8-pole synchronous servomotors
- Neodymium-iron-boron magnets for maximum torque
- 240V ac, 320V dc bus maximum operation
- IP40 construction
- MS-type or AMP mini Mate-N-Lock® connectors on 18" leads
- Rated speeds to 10,000 RPM

The PMB2 series of cost-effective brushless servomotors covers a continuous torque range from 0.45 to 1.40 Nm. These compact motors are well-suited for speed and position control applications requiring high acceleration and torque in a compact package — especially for light-industrial, high-volume applications.

RATINGS AND CHARACTERISTICS

Motor parameters and winding data. See system data beginning on page 4 for typical torque/speed performance.

PARAMETER	SYMBOL	UNITS	PMB21		PMB22		PMB23	
Continuous stall torque ^{① ②}	T_{CS}	Nm (lb.-in.)	0.64 (5.7)		1.11 (9.8)		1.54 (13.6)	
Peak torque ^{③ ④}	T_{PK}	Nm (lb.-in.)	1.92 (17.0)		3.29 (29.1)		4.56 (40.4)	
Inertia ^⑤	J_M	$\text{kgm}^2 \times 10^{-3}$ (lb.-in.-sec ² × 10 ⁻³)	0.023 (0.206)		0.044 (0.390)		0.065 (0.576)	
Static friction (max.)	T_f	Nm (lb.-in.)	0.034 (0.30)		0.068 (0.60)		0.102 (0.90)	
Viscous damping coefficient	K_{DV}	Nm/kRPM (lb.-in./kRPM)	0.0079 (0.07)		0.0124 (0.11)		0.0181 (0.60)	
Thermal resistance	R_{TH}	deg. C/Watt	1.39		1.28		1.10	
Thermal time constant	τ_{TH}	min.	22		24		26	
Weight (motor only)	W	kg (lbs.)	1.2 (2.7)		2.1 (4.6)		2.9 (6.4)	
WINDING DATA			B	D	B	D	B	C
Torque constant (RMS)	K_t	Nm/A_{RMS} (lb.-in./ A_{RMS})	0.34 (2.99)	0.13 (1.14)	0.42 (3.7)	0.22 (1.98)	0.57 (5.0)	0.44 (3.9)
Voltage constant (RMS) (I-n)	K_E	$V_{RMS}/\text{rad}/\text{sec}$ (V_{RMS}/kRPM)	0.22 (22.7)	0.09 (9.1)	0.27 (28.8)	0.14 (15.0)	0.37 (39.0)	0.29 (29.9)
Continuous stall current ^{① ②}	I_{CS}	A_{RMS}	2.6	5.0	2.65	4.95	2.7	3.5
Current at peak torque ^④	I_{PK}	A_{RMS}	7.8	15.0	8.0	14.9	8.1	10.5
Resistance (line-to-line)	R_C	Ohms	6.0	1.7	6.2	1.9	7.7	4.0
Inductance (line-to-line)	L	mH	4.0	1.2	5.5	1.5	7.1	3.7
Typical Rated Speed @ 36V ac, 48V dc bus	W_R	RPM	n/a	1,300	n/a	600	n/a	n/a
Typical Rated Torque @ 36V ac, 48V dc bus	T_{CR}	Nm (lb.-in.)	n/a (n/a)	0.61 (5.4)	n/a (n/a)	1.10 (9.7)	n/a (n/a)	n/a (n/a)
Typical Rated Speed @ 240V ac, 320V dc bus	W_R	RPM	10,000	n/a	6,250	n/a	4,400	6,000
Typical Rated Torque @ 240V ac, 320V dc bus	T_{CR}	Nm (lb.-in.)	.45 (4.0)	n/a (n/a)	1.01 (8.9)	n/a (n/a)	1.40 (12.4)	1.33 (11.8)

Note: All values at 25°C unless otherwise noted.

① Motor operated at rated winding temperature rise of $\Delta t = 100^\circ\text{C}$ above ambient at 25°C ambient. Ratings result of average rating between free air and cold plate mounting. Equivalent to mounting to a 10" x 10" x 1/4" aluminum heat sink.

② All tests performed with sinusoidal commutation.

③ Theoretical motor maximum.

④ Caution: For peak torques or peak currents greater than 4x the continuous rating, consult the factory for thermal considerations.

⑤ Motor with resolver feedback.

NEMA Mount Shown

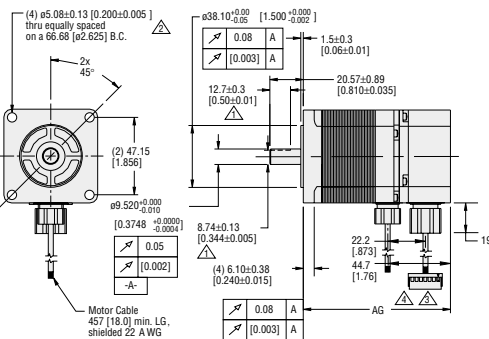

Motor	Length	Inertia - with resolver		Inertia - with encoder	
	mm (in.)	$\text{kgm}^2 \times 10^{-3}$	$\text{lb-in.-sec}^2 \times 10^{-3}$	$\text{kgm}^2 \times 10^{-3}$	$\text{lb-in.-sec}^2 \times 10^{-3}$
PMB21	112.8 (4.44)	.023	.206	.023	.201
PMB22	142.0 (5.59)	.044	.390	.044	.385
PMB23	176.3 (6.94)	.065	.576	.065	.571

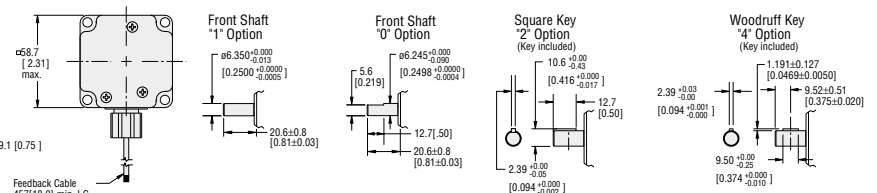

Notes:

△ "0" option (flat) shaft shown.

△ Recommended mounting hardware: (4) fillister-lead or socket-lead cap screws – #6 for PMB1 & 2, #10 for PMB3.

△ Option "1" includes an AMP® mini universal Mate-N-Lock connector for power and feedback.

△ Cable minimum bend radius 57.2 mm (2.25 in.).

△ "2" option (square key shown) for shaft.

PMB3 SERIES MOTOR



- 8-pole synchronous servomotors
- Neodymium-iron-boron magnets for maximum torque
- 240V ac, 320V dc bus maximum operation
- IP40 construction
- MS-type or AMP mini Mate-N-Lock® connectors on 18" lead
- Rated speeds to 6,000 RPM

The PMB3 series of cost-effective brushless servomotors covers a continuous torque range from 1.62 to 4.84 Nm. These compact motors are well-suited for speed and position control applications requiring high acceleration and torque in a compact package — especially for light-industrial, high-volume applications.

RATINGS AND CHARACTERISTICS

Motor parameters and winding data. See system data beginning on page 4 for typical torque/speed performance.

PARAMETER	SYMBOL	UNITS	PMB31		PMB32			PMB33		
Continuous stall torque ^{① ②}	T _{CS}	Nm (lb.-in.)	2.11 (18.7)		3.84 (34.0)			5.42 (48.0)		
Peak torque ^{③ ④}	T _{PK}	Nm (lb.-in.)	6.26 (55.4)		11.40 (101)			16.1 (142)		
Inertia ^⑤	J _M	kgm ² ×10 ⁻³ (lb.-in.-sec ² ×10 ⁻³)	0.137 (1.21)		0.27 (2.39)			0.404 (3.57)		
Static friction (max.)	T _f	Nm (lb.-in.)	0.09 (0.80)		0.12 (1.10)			0.169 (1.50)		
Viscous damping coefficient	K _{DV}	Nm/kRPM (lb.-in./kRPM)	0.0124 (0.110)		0.026 (0.23)			0.038 (0.34)		
Thermal resistance	R _{TH}	deg. C/Watt	1.08		0.92			0.78		
Thermal time constant	τ _{TH}	min.	28		30			32		
Weight (motor only)	W	kg (lbs.)	2.5 (5.5)		4.4 (9.7)			6.3 (13.8)		
WINDING DATA			B	D	C	D	E	C	E	F
Torque constant (RMS)	K _T	Nm/A _{RMS} (lb.-in./A _{RMS})	0.79 (7.03)	0.41 (3.67)	1.30 (11.5)	0.74 (6.5)	0.57 (5.0)	1.86 (16.5)	0.93(8.2)	0.60 (5.3)
Voltage constant (RMS) (I-n)	K _E	V _{RMS} /rad/sec (V _{RMS} /kRPM)	0.49 (51.3)	0.25 (26.4)	0.82 (85.4)	0.46 (48.4)	0.35 (37.1)	1.11 (117)	0.56 (58.4)	0.37 (38.7)
Continuous stall current ^{① ②}	I _{CS}	A _{RMS}	2.66	5.1	2.95	5.2	6.8	2.9	5.8	9.0
Current at peak torque ^④	I _{PK}	A _{RMS}	8.0	15.3	8.9	15.6	20.4	8.7	17.5	27.1
Resistance (line-to-line)	R _C	Ohms	7.6	2.0	7.2	2.3	1.4	8.6	2.2	0.96
Inductance (line-to-line)	L	mH	19.6	5.2	22.5	7.4	20.4	27.2	6.8	2.8
Typical Rated Speed @ 240V ac, 320V dc bus	W _R	RPM	2,900	6,000	1,900	3,500	4,450	1,300	3,000	4,600
Typical Rated Torque @ 240V ac, 320V dc bus	T _{DR}	Nm (lb.-in.)	1.90 (16.8)	1.62 (14.3)	2.98 (26.4)	2.85 (25.2)	2.77 (24.5)	4.84 (42.8)	4.41 (39.0)	4.04 (35.8)

Note: All values at 25°C unless otherwise noted.

① Motor operated at rated winding temperature rise of Δt = 100°C above ambient at 25°C ambient. Ratings result of average rating between free air and cold plate mounting. Equivalent to mounting to a 10" x 10" x 1/4" aluminum heat sink.

② All tests performed with sinusoidal commutation.

③ Theoretical motor maximum.

④ Caution: For peak torques or peak currents greater than 4x the continuous rating, consult the factory for thermal considerations.

⑤ Motor with resolver feedback.

NEMA Mount Shown

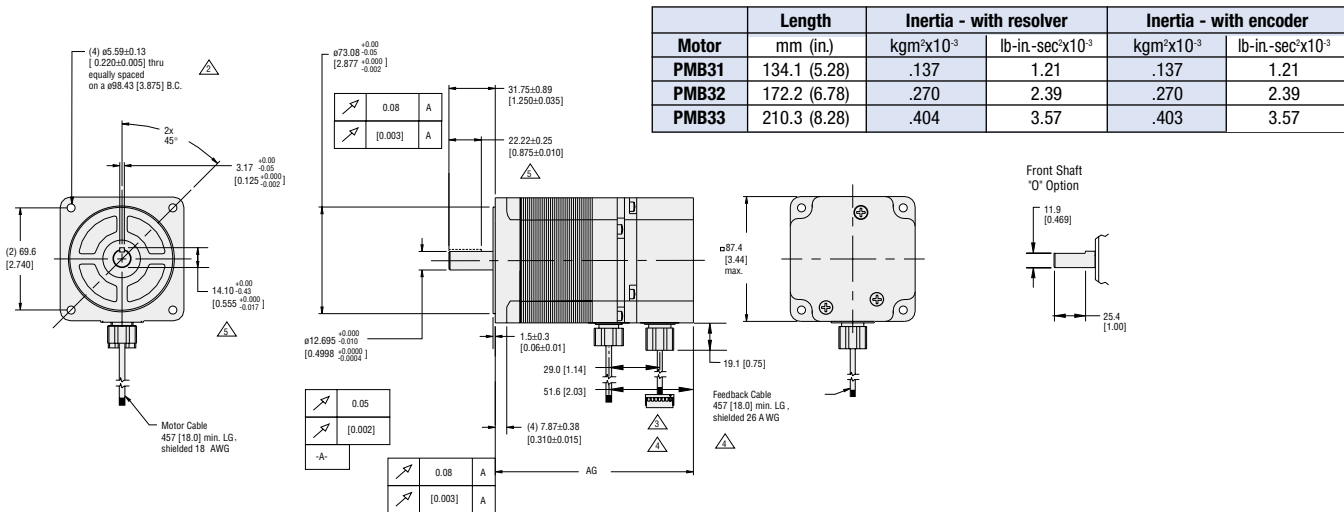

Notes:

- ▲ "0" option (flat) shaft shown.
- ▲ Recommended mounting hardware: (4) fillister-lead or socket-lead cap screws – #6 for PMB1 & 2, #10 for PMB3.
- ▲ Option "1" includes an AMP® mini universal Mate-N-Lock connector for power and feedback .
- ▲ Cable minimum bend radius 57.2 mm (2.25 in.).
- ▲ "2" option (square key shown) for shaft.

S SERIES BRUSHLESS SERVO MOTORS

HIGH TORQUE PER FRAME SIZE — MEDIUM INERTIA FOR IMPROVED LOAD MATCHING

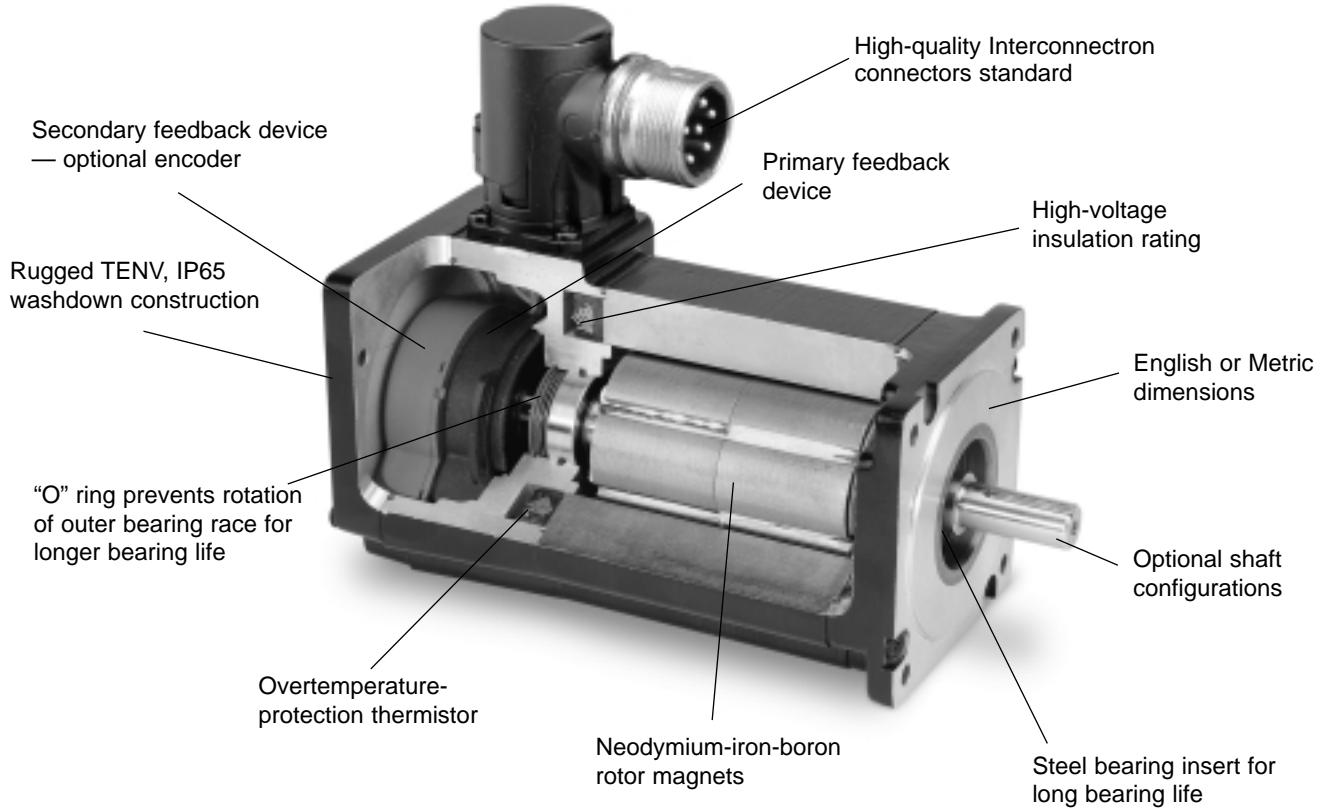

MODEL NUMBER CODE

To construct a motor listing, select the combination of features required and put all the coded information in the proper sequence. Please account for all entries. The model number shown is an example of a properly specified motor.

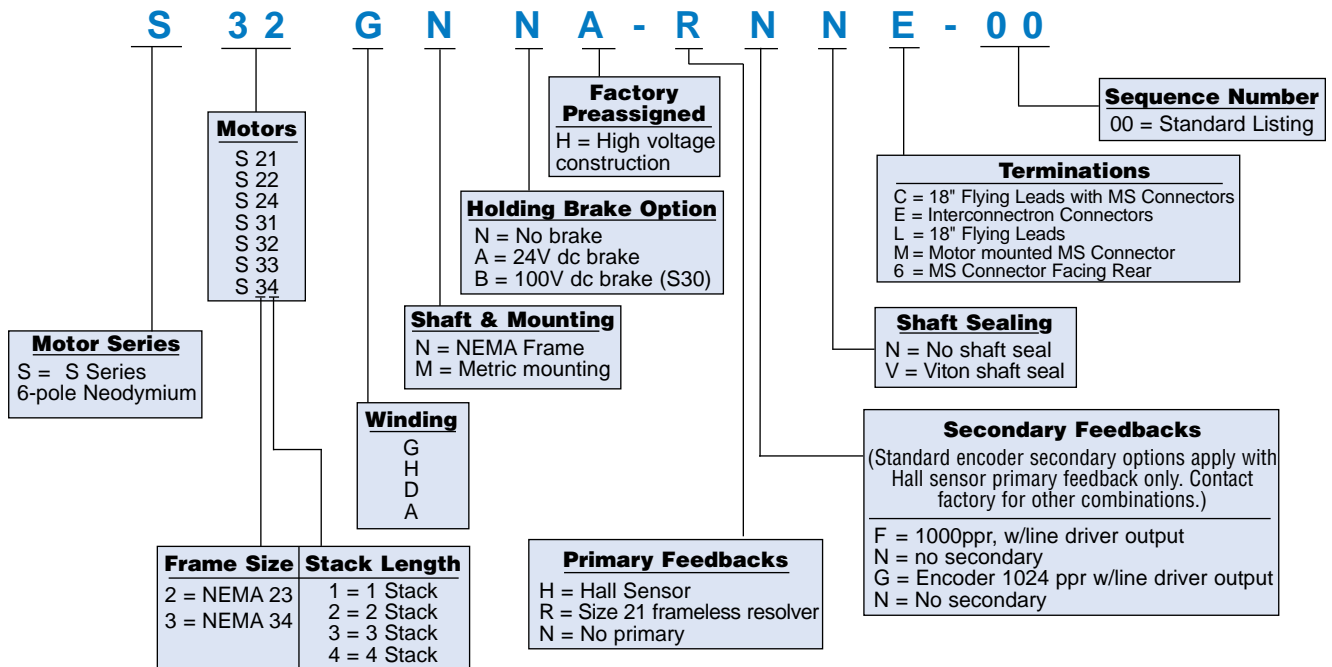

S20 SERIES MOTOR

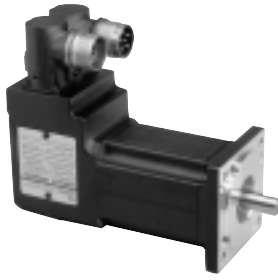

- 6-pole synchronous servomotors
- Neodymium-iron-boron magnets for maximum torque
- Long-life bearing system
- IP65 protection
- Anti-cog stator design
- High-quality Interconnectron connectors
- Rated speeds to 12,500 RPM

The S20 Series motors cover a continuous torque range from 0.32 to 1.6 Nm. These compact motors are well-suited for speed and position control applications requiring maximum performance in minimum space. The S20 Series is available with other primary and secondary feedback devices, in addition to the standard resolver primary feedback, allowing for integration with other control schemes.

RATINGS AND CHARACTERISTICS

Motor parameters and winding data. See system data beginning on page 4 for typical torque/speed performance.

PARAMETER	SYMBOL	UNITS	S21		S22		S24	
Continuous stall torque ^①	T _{CS}	Nm (lb.-in.)	0.5 (4.5)		1.0 (8.8)		1.6 (14.4)	
Peak torque ^②	T _{PK}	Nm (lb.-in.)	1.36 (12.0)		2.64 (23.4)		4.94 (43.7)	
Inertia ^③	J _M	kgm ² x10 ⁻³ (lb.-in.-sec ² x10 ⁻³)	0.042 (0.38)		0.064 (0.56)		0.100 (0.89)	
Static friction (max.)	T _f	Nm (lb.-in.)	0.008 (0.07)		0.010 (0.09)		0.025 (0.22)	
Viscous damping coefficient	K _{DV}	Nm/kRPM (lb.-in./kRPM)	0.003 (0.03)		0.006 (0.05)		0.012 (0.11)	
Thermal resistance ^⑤	R _{TH}	deg. C/Watt	2.2		1.7		1.29	
Thermal time constant	τ _{TH}	min.	5.0		11.0		15.0	
Weight (motor only)	W	kg (lbs.)	1.4 (3.1)		1.9 (4.2)		2.7 (6.0)	
WINDING DATA			G	H	G	H	G	H
Torque constant (RMS) ^②	K _t	Nm/A _{RMS} (lb.-in./A _{RMS})	0.3 (2.7)	0.2 (1.8)	0.7 (6.2)	0.3 (2.7)	0.6 (5.3)	0.3 (2.7)
Voltage constant (RMS) ^②	K _e	V _{RMS} /rad/sec (V _{RMS} /kRPM)	0.19 (19.9)	0.13 (13.6)	0.44 (46.1)	0.19 (19.9)	0.38 (39.8)	0.19 (19.9)
Continuous stall current ^①	I _{CS}	A _{RMS}	1.5	3.1	1.5	2.9	2.6	5.1
Current at peak torque ^④	I _{PK}	A _{RMS}	4.5	9.3	4.5	8.7	7.8	15.3
Resistance (line-to-line)	R _c	Ohms	12.0	3.0	16.2	4.2	6.8	1.8
Inductance (line-to-line)	L	mH	14.4	3.7	22.1	5.7	9.3	2.2
Typical Rated Speed @ 240V ac, 320V dc bus	W _R	RPM	7,900	12,500	3,800	7,600	3,400	7,000
Typical Rated Torque @ 240V ac, 320V dc bus	T _{CR}	Nm (lb.-in.)	0.44 (3.9)	0.32 (2.8)	0.92 (8.1)	0.70 (6.2)	1.5 (12.9)	0.7 (6.6)

Metric Mount Shown — also available in NEMA mount. Consult factory or website for details.

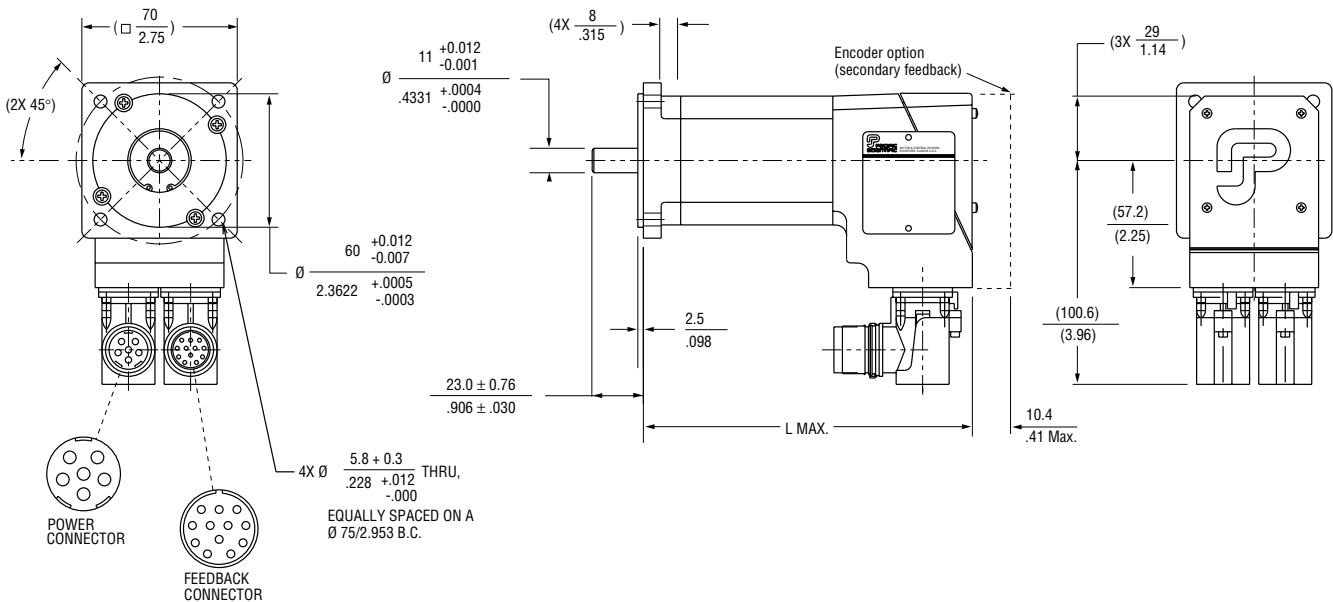

- ① Windings at 155°C. Motor in 25°C ambient and mounted to a 10" x 10" x 1/4" aluminum heat sink.
- ② RMS value of a sinusoidal waveform, measured line to neutral.
- ③ Motor with resolver feedback.
- ④ Caution: For peak torques or peak currents greater than 3x the continuous rating, consult the factory for thermal considerations.
- ⑤ Motor in 25°C ambient, mounted to a 10" x 10" x 1/4" aluminum heat sink.

Motor	S21	S22	S24
L Max	124.0 (4.88)	149.4 (5.88)	200.2 (7.88)

mm (in.)

S30 SERIES MOTOR

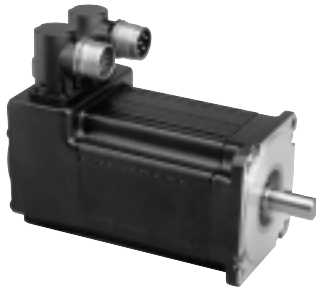

- 6-pole synchronous servomotors
- Neodymium-iron-boron magnets for maximum torque
- 240V to 480V ac operation
- Long-life bearing system
- IP65 protection
- Anti-cog stator design
- High-quality Interconnectron connectors
- Rated speeds to 3,900 RPM

The S30 Series motors cover a continuous torque range from 1.9 to 6.6 Nm. These compact motors are well-suited for speed and position control applications requiring maximum performance in minimum space. The S30 Series is available with other primary and secondary feedback devices, in addition to the standard resolver primary feedback, allowing for integration with other control schemes.

RATINGS AND CHARACTERISTICS

Motor parameters and winding data. See system data beginning on page 4 for typical torque/speed performance.

PARAMETER	SYMBOL	UNITS	S31		S32		S33		S34				
Continuous stall torque ^①	T _{CS}	Nm (lb.-in.)	2.2 (19.5)		4.0 (35.4)		5.3 (46.9)		6.6 (58.4)				
Peak torque ^②	T _{PK}	Nm (lb.-in.)	6.2 (55.0)		11.3 (100)		15.3 (135)		25.3 (224)				
Inertia ^③	J _M	kgm ² x10 ⁻³ (lb.-in.-sec ² x10 ⁻³)	0.18 (1.58)		0.34 (2.98)		0.48 (4.28)		0.64 (5.68)				
Static friction (max.)	T _f	Nm (lb.-in.)	0.06 (0.56)		0.15 (1.31)		0.17 (1.50)		0.19 (1.70)				
Viscous damping coefficient	K _{DV}	Nm/kRPM (lb.-in./kRPM)	0.016 (0.15)		0.039 (0.35)		0.047 (0.42)		0.073 (0.65)				
Thermal resistance ^④	R _{TH}	deg. C/Watt	1.23		0.97		0.87		0.85				
Thermal time constant	τ _{TH}	min.	14.0		24.0		27.0		30.0				
Weight (motor only)	W	kg (lbs.)	3.2 (7.1)		4.9 (10.7)		6.5 (14.2)		8.1 (17.8)				
WINDING DATA			G	H	G	H	A	D	G	H	A	G	H
Torque constant (RMS) ^②	K _t	Nm/Arms (lb.-in./A _{RMS})	1.3 (11.5)	0.7 (6.2)	1.3 (11.5)	0.7 (6.2)	1.5 (13.3)	0.8 (6.7)	1.9 (16.8)	0.9 (8.0)	1.7 (15.0)	2.1 (18.6)	1.1 (9.6)
Voltage constant (RMS) ^②	K _e	V _{RMS} /rad/sec (V _{RMS} /kRPM)	0.82 (85.9)	0.44 (46.1)	0.82 (85.9)	0.44 (46.1)	0.94 (98.4)	.47 (49.6)	1.19 (125)	0.56 (58.6)	1.07 (112)	1.32 (138)	.68 (71.1)
Continuous stall current ^①	I _{CS}	A _{RMS}	1.7	3.3	3.1	6.1	3.5	7.0	2.8	5.6	3.9	3.1	6.1
Current at peak torque ^④	I _{PK}	A _{RMS}	6.0	11.7	10.9	21.4	12.3	24.6	9.7	19.7	13.7	10.9	21.4
Resistance (line-to-line)	R _C	Ohms	16.4	4.1	6.2	1.6	5.2	1.3	8.4	2.1	4.4	7.2	1.8
Inductance (line-to-line)	L	mH	41.2	10.3	18.0	4.5	17.0	4.4	25.2	6.3	14.7	23.7	5.9
Typical Rated Speed @ 240V ac, 320V dc bus	W _R	RPM	1,800	3,500	1,500	3,900	1,500	3,600	1,400	3,200	1,500	1,300	2,000
Typical Rated Torque @ 240V ac, 320V dc bus	T _{CR}	Nm (lb.-in.)	2.2 (19.1)	1.9 (16.6)	3.6 (32.3)	2.8 (24.9)	4.7 (41.3)	3.7 (32.6)	4.8 (42.8)	3.9 (34.4)	5.6 (49.3)	5.8 (51.1)	6.4 (56.8)
Typical Rated Speed @ 400V ac, 560V dc bus	W _R	RPM	N/A	N/A	N/A	N/A	3,000	N/A	N/A	N/A	3,000	N/A	N/A
Typical Rated Torque @ 400V ac, 560V dc bus	T _{CR}	Nm (lb.-in.)	N/A	N/A	N/A	N/A	4.0 (35.6)	N/A	N/A	N/A	4.3 (37.9)	N/A	N/A
Typical Rated Speed @ 480V ac, 640V dc bus	W _R	RPM	N/A	N/A	N/A	N/A	3,900	N/A	N/A	N/A	3,600	N/A	N/A
Typical Rated Torque @ 480V ac, 640V dc bus	T _{CR}	Nm (lb.-in.)	N/A	N/A	N/A	N/A	3.6 (32.1)	N/A	N/A	N/A	3.9 (34.2)	N/A	N/A

Metric Mount Shown — also available in NEMA mount. Consult factory or website for details.

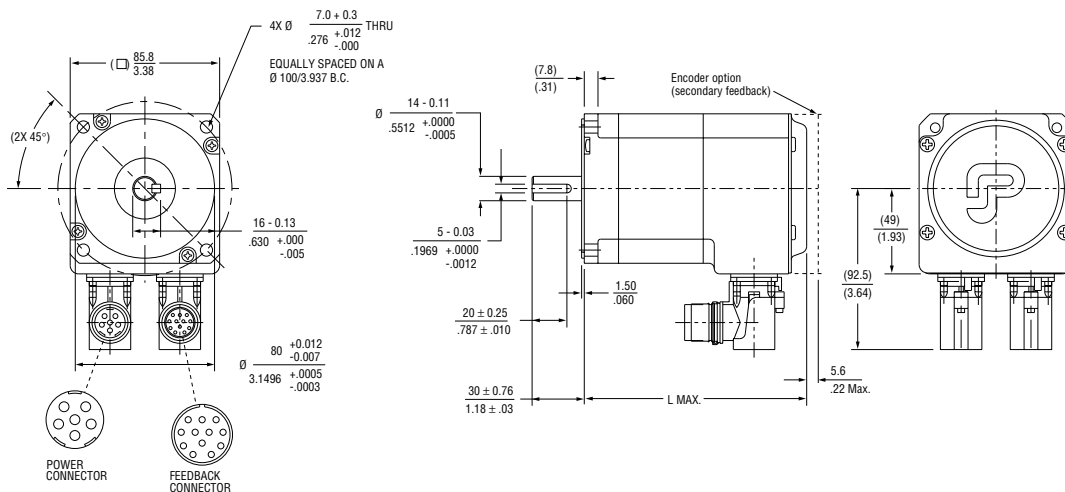

- ① Windings at 155°C. Motor in 25°C ambient and mounted to a 10" x 10" x 1/4" aluminum heat sink.
- ② RMS value of a sinusoidal waveform, measured line to neutral.
- ③ Motor with resolver feedback.
- ④ Caution: For peak torques or peak currents greater than 3.5x the continuous rating, consult the factory for thermal considerations.
- ⑤ Motor in 25°C ambient, mounted to a 10" x 10" x 1/4" aluminum heat sink.

Motor	S31	S32	S33	S34
L Max	130.3 (5.13)	168.4 (6.63)	206.5 (8.13)	244.6 (9.63)

mm (in.)

R20 SERIES

2" OD ROUND -FRAME MOTOR

HIGH DYNAMIC RESPONSE OVER A WIDE SPEED RANGE — IN A COMPACT PACKAGE

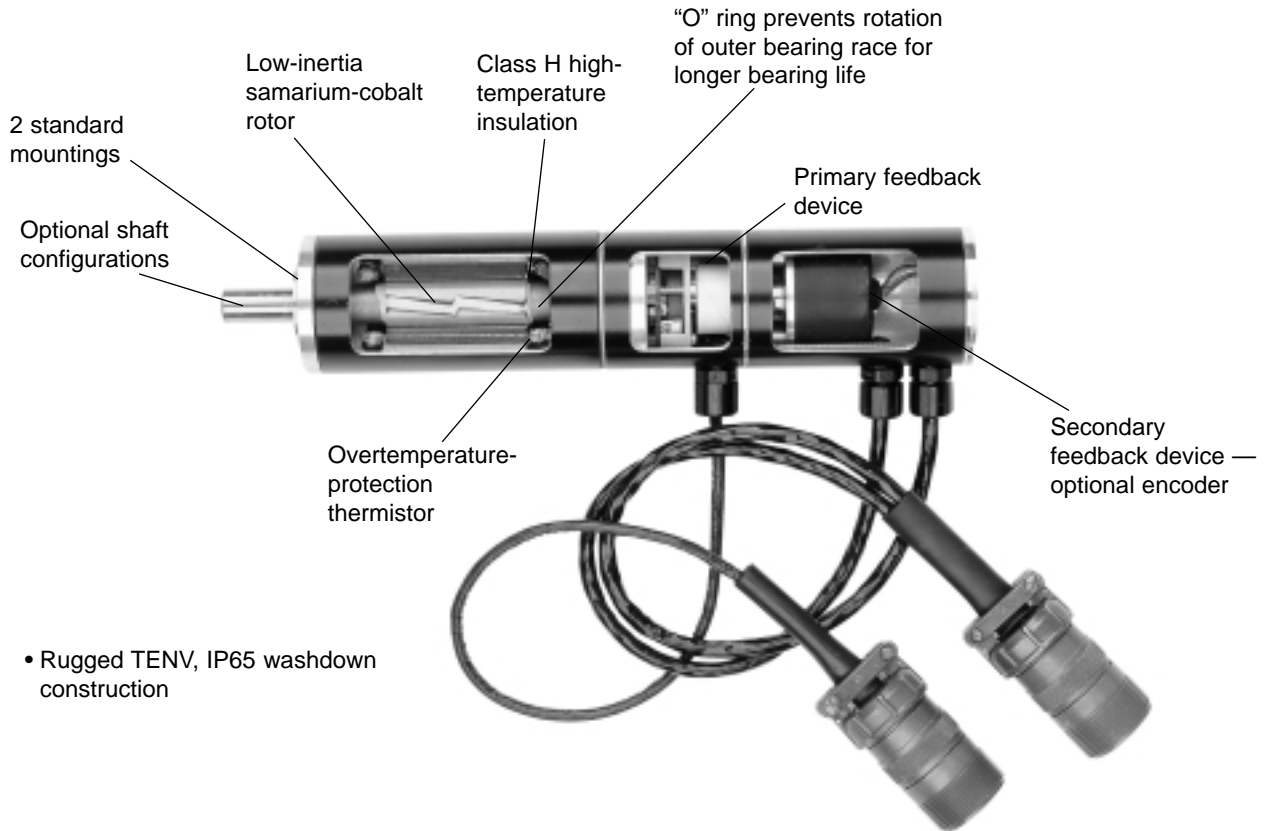

- Rugged TENV, IP65 washdown construction

MODEL NUMBER CODE. . . R20 Series

To construct a motor listing, select the combination of features required and put all the coded information in the proper sequence. Please account for all entries. Include the factory-preassigned "N" and "A" as noted. The model number shown is an example of a properly specified motor.

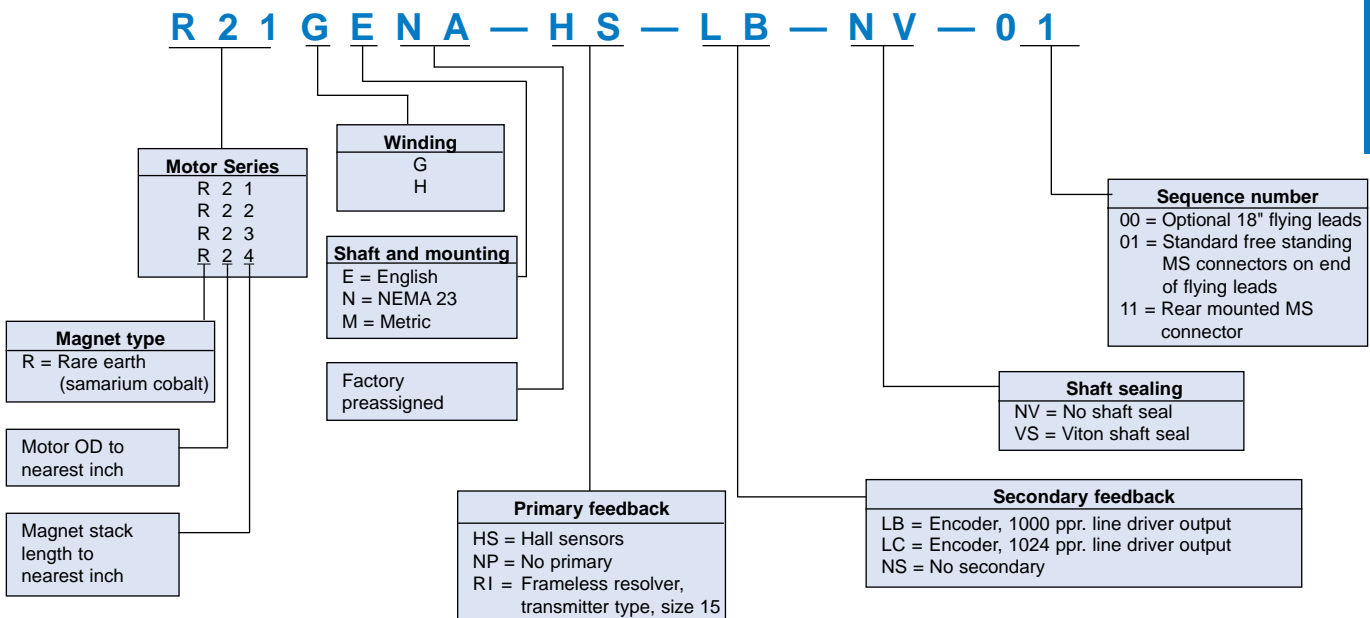

R-SERIES

R20 SERIES MOTOR — 2" OD (round frame)



- 4-pole synchronous servomotors
- Samarium-cobalt permanent magnets for maximum torque-to-inertia without demagnetization
- 240V ac, 320V dc bus maximum operation
- Anti-cog stator design
- MS-type connectors on 18" leads
- Rated speeds to 11,000 RPM

The R20 Series of round brushless servomotors covers a continuous torque range from 0.3 to 1.1 Nm. These compact motors are well-suited for speed and position control applications that require high acceleration and torque in a compact package.

RATINGS AND CHARACTERISTICS

Motor parameters and winding data. See system data beginning on page 4 for typical torque/speed performance.

PARAMETER	SYMBOL	UNITS	R21	R22	R23	R24				
Continuous stall torque ^①	T _{CS}	Nm (lb.-in.)	0.3 (2.7)	0.6 (5.3)	0.9 (8.0)	1.1 (9.7)				
Peak torque ^②	T _{PK}	Nm (lb.-in.)	0.88 (7.8)	1.62 (14.3)	2.54 (22.5)	3.07 (27.2)				
Inertia ^③	J _M	kgm ² x10 ⁻³ (lb.-in.-sec ² x10 ⁻³)	0.01 (0.09)	.014 (.12)	.018 (0.16)	0.021 (.19)				
Static friction (max.)	T _f	Nm (lb.-in.)	0.01 (0.10)	0.02 (0.17)	0.03 (0.24)	0.04 (0.31)				
Viscous damping coefficient	K _{DV}	Nm/kRPM (lb.-in./kRPM)	0.003 (0.03)	0.005 (0.04)	0.006 (0.05)	0.008 (0.07)				
Thermal resistance ^④	R _{TH}	deg. C/Watt	1.65	1.43	1.27	1.27				
Thermal time constant	τ _{TH}	min.	8.0	12.0	15.0	17.0				
Weight (motor only)	W	kg (lbs.)	0.68 (1.5)	0.95 (2.1)	1.3 (2.8)	1.5 (3.4)				
WINDING DATA										
			G	H	G	H	G	H	G	H
Torque constant (RMS) ^②	K _T	Nm/A _{RMS} (lb.-in./A _{RMS})	0.4 (3.5)	0.2 (1.8)	0.4 (3.5)	0.2 (1.8)	0.6 (5.3)	0.3 (2.7)	0.7 (6.2)	0.4 (0.24)
Voltage constant (RMS) ^②	K _E	V _{RMS} /rad/sec (V _{RMS} /kRPM)	0.24 (25.1)	0.12 (12.6)	0.24 (25.1)	0.12 (12.6)	0.36 (37.7)	0.18 (18.8)	0.43 (45.0)	3.5 (25.1)
Continuous stall current ^①	I _{CS}	A _{RMS}	0.7	1.5	1.4	2.7	1.5	3.0	1.1	1.1
Current at peak torque ^②	I _{PK}	A _{RMS}	2.1	4.5	4.2	8.1	4.5	9.0	4.5	9.0
Resistance (line-to-line)	R _C	Ohms	62.0	16.0	22.0	5.4	20.0	4.9	22.0	5.5
Inductance (line-to-line)	L	mH	47.0	12.0	21.0	5.3	26.0	6.5	26.0	6.5
Typical Rated Speed @ 240V ac, 320V dc bus	W _R	RPM	4,000	11,000	5,300	8,000	3,800	8,000	3,000	7,700
Typical Rated Torque @ 240V ac, 320V dc bus	T _{CR}	Nm (lb.-in.)	0.31 (2.7)	0.17 (1.5)	0.47 (4.2)	0.29 (2.6)	0.80 (7.1)	0.61 (5.4)	1.03 (9.1)	0.79 (7.0)

Metric Mount Shown — also available in English mount. Consult factory or website for details.

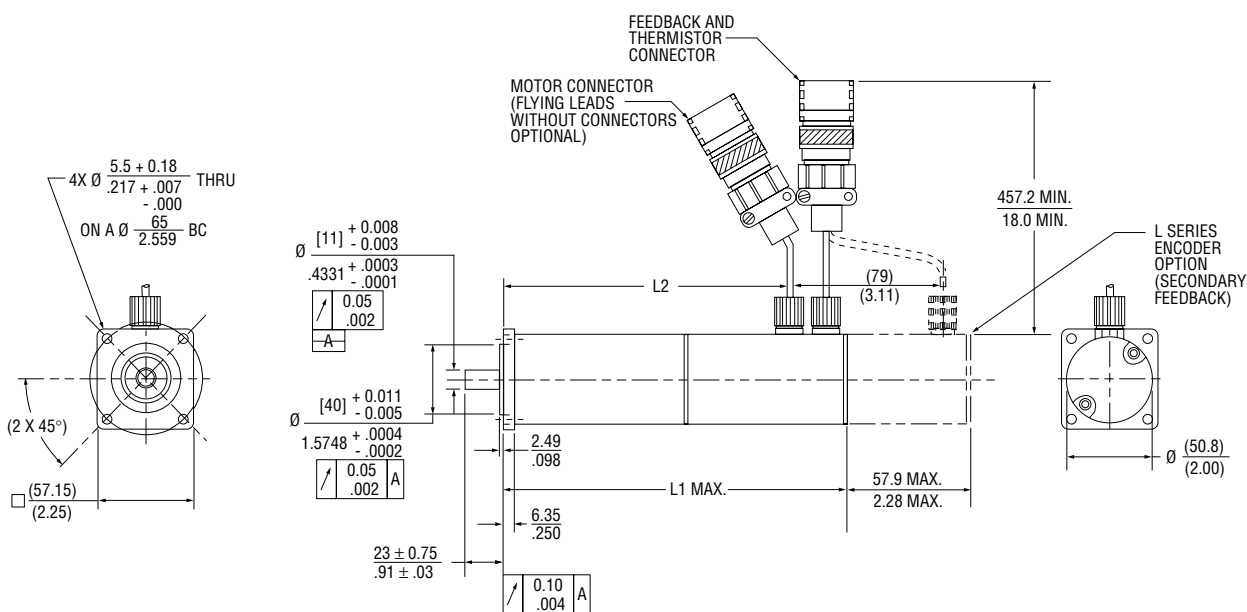

Note: All values at 25°C unless otherwise noted.

① Windings at 155°C. Motor in 25°C ambient and mounted to a 10" x 10" x 1/4" aluminum heat sink.

② RMS value of a sinusoidal waveform, measured line to neutral.

③ Motor with resolver feedback.

④ Caution: For peak torques or peak currents greater than 3x the continuous rating, consult the factory for thermal considerations.

⑤ Motor in 25°C ambient, mounted to a 10" x 10" x 1/4" aluminum heat sink.

Motor	R21	R22	R23	R24
L1 Max	162.1 (6.38)	187.5 (7.38)	212.9 (8.38)	238.3 (9.38)
L2	125.2 (4.93)	150.6 (5.93)	176.0 (6.93)	201.4 (7.93)

mm (in.)

R SERIES

3.25," 4.25," 5.75," AND 7.5" SQUARE FRAME MOTORS

All motors are UL Recognized (Files E103510 and E61960)



HIGH TORQUE-TO-INERTIA FOR UNMATCHED PERFORMANCE

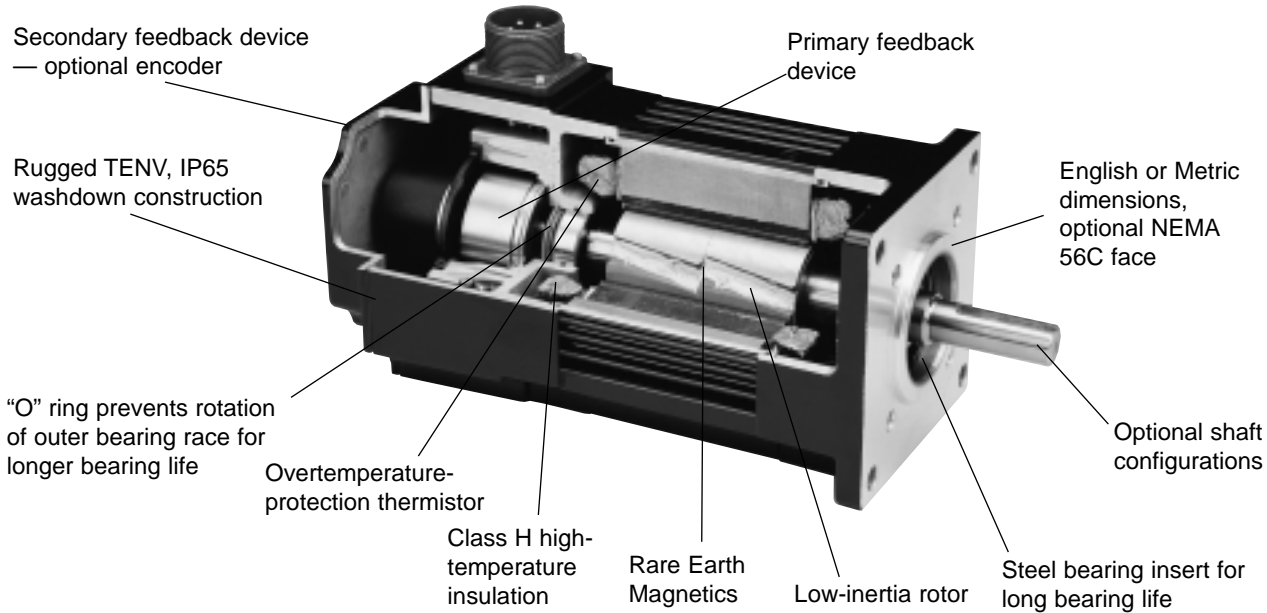

MODEL NUMBER CODE. . . R30/R40/R60/R80 Series

To construct a motor listing, select the combination of features required and put all the coded information in the proper sequence. Please account for all entries. The model number shown is an example of a properly specified motor.

R 4 3 G E N A — H S — N D — N V — 0 0

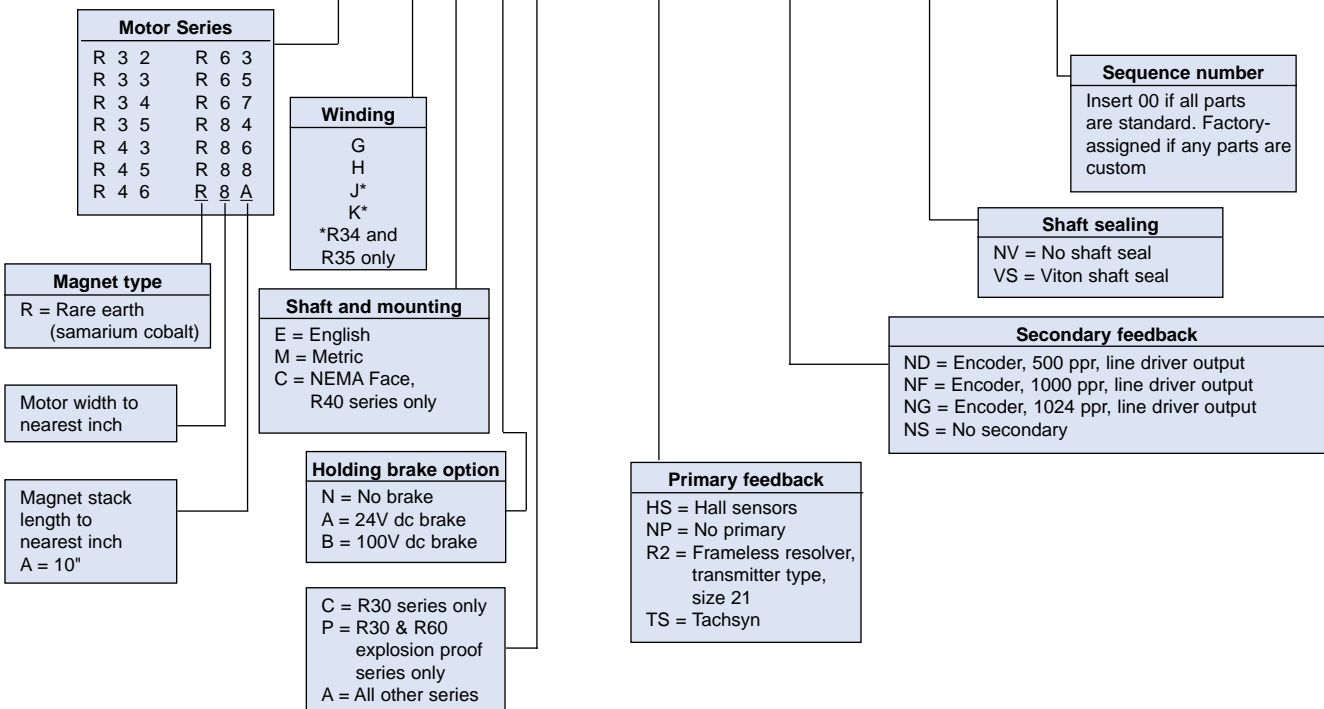

R-SERIES

R30 SERIES MOTOR — 3.25" width/height (square frame)

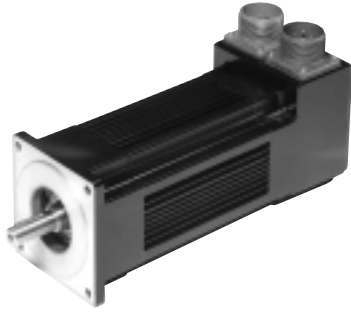

- 4-pole synchronous servomotors
- Samarium-cobalt permanent magnets for maximum torque-to-inertia without demagnetization
- Low rotor inertia for rapid accel/decel
- 240V ac, 320V dc bus operation
- Anti-cog stator design
- Rated speeds to 7,000 RPM

The R30 Series motors cover a continuous torque range from 1.7 to 3.8 Nm. These compact motors are well-suited for speed and position control applications that require maximum performance in minimum space.

RATINGS AND CHARACTERISTICS

Motor parameters and winding data. See system data beginning on page 4 for typical torque/speed performance.

PARAMETER	SYMBOL	UNITS	R32		R33		R34		R35	
Continuous stall torque ^①	T _{CS}	Nm (lb.-in.)	1.7 (15.0)		2.5 (22.1)		3.2 (28.3)		3.8 (33.6)	
Peak torque ^④	T _{PK}	Nm (lb.-in.)	4.40 (39.0)		6.54 (57.9)		8.30 (73.5)		10.1 (89.4)	
Inertia ^③	J _M	kgm ² x10 ⁻³ (lb.-in.-sec ² x10 ⁻³)	.071 (.63)		0.093 (.82)		0.11 (1.00)		.13 (1.19)	
Static friction (max.)	T _f	Nm (lb.-in.)	0.03 (0.23)		0.04 (0.31)		0.04 (0.39)		0.05 (0.47)	
Viscous damping coefficient	K _{DV}	Nm/kRPM (lb.-in./kRPM)	0.005 (0.04)		0.007 (0.06)		0.01 (0.09)		0.012 (0.11)	
Thermal resistance ^⑤	R _{TH}	deg. C/Watt	0.93		0.84		0.76		0.70	
Thermal time constant	τ _{TH}	min.	20.0		23.0		26.0		29.0	
Weight (motor only)	W	kg (lbs.)	2.5 (5.5)		3.2 (7.1)		3.9 (8.7)		4.6 (10.2)	
WINDING DATA										
			G	H	G	H	J	K	J	K
Torque constant (RMS) ^②	K _T	Nm/A _{RMS} (lb.-in./A _{RMS})	0.6 (5.3)	0.3 (2.7)	0.8 (7.1)	0.4 (3.5)	1.1 (9.7)	0.5 (4.4)	1.3 (11.5)	0.6 (5.3)
Voltage constant (RMS) ^②	K _E	V _{RMS} /rad/sec (V _{RMS} /kRPM)	0.36 (37.7)	0.18 (18.8)	0.49 (51.3)	0.24 (25.1)	0.67 (70.2)	0.3 (31.4)	0.79 (82.7)	0.36 (37.7)
Continuous stall current ^①	I _{CS}	A _{RMS}	2.9	5.8	3.2	6.4	3.0	6.1	2.9	6.0
Current at peak torque ^④	I _{PK}	A _{RMS}	8.7	17.4	9.6	19.2	9.0	18.3	8.7	18.0
Resistance (line-to-line)	R _C	Ohms	7.3	1.8	6.9	1.7	8.1	2.0	9.2	2.3
Inductance (line-to-line)	L	mH	23.0	5.8	22.0	5.6	30.0	7.5	42.0	10.5
Typical Rated Speed @ 240V ac, 320V dc bus	W _R	RPM	4,000	7,000	3,000	6,000	2,300	4,000	1,700	4,200
Typical Rated Torque @ 240V ac, 320V dc bus	T _{CR}	Nm (lb.-in.)	1.2 (10.5)	0.76 (6.7)	1.9 (16.6)	1.2 (10.7)	2.9 (25.3)	1.9 (17.2)	3.7 (32.5)	2.4 (21.6)

Metric Mount Shown — also available in English mount. Consult factory or website for details.

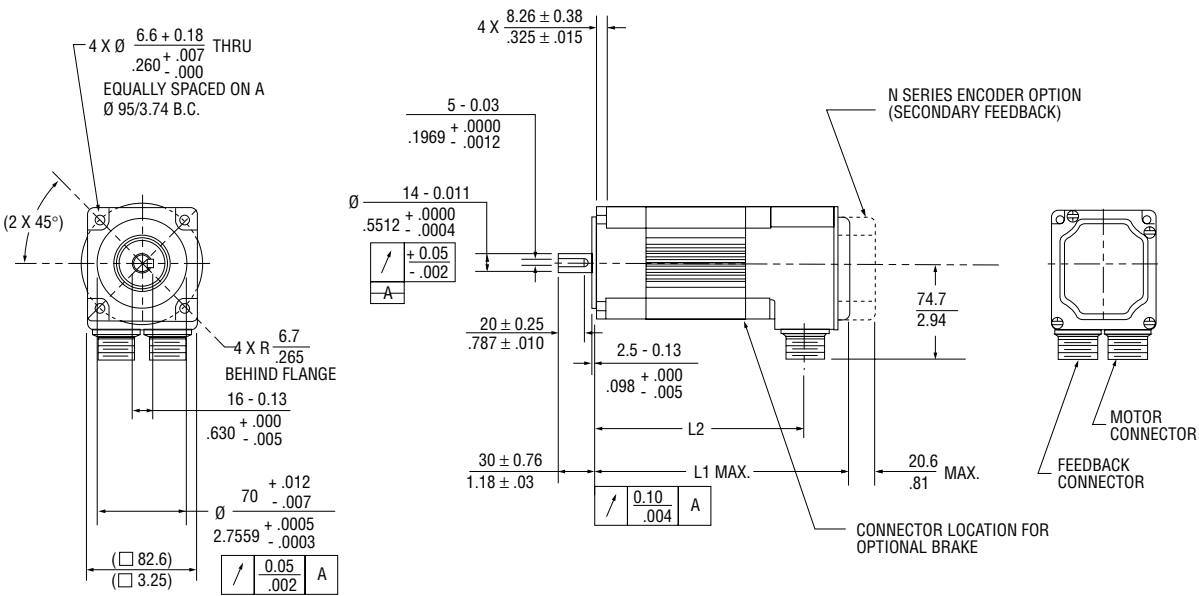

Note: All values at 25°C unless otherwise noted.

- ① Windings at 155°C. Motor in 25°C ambient and mounted to a 10" x 10" x 1/4" aluminum heat sink.
- ② RMS value of a sinusoidal waveform, measured line to neutral.
- ③ Motor with resolver feedback.
- ④ Caution: For peak torques or peak currents greater than 3x the continuous rating, consult the factory for thermal considerations.
- ⑤ Motor in 25°C ambient, mounted to a 10" x 10" x 1/4" aluminum heat sink.

Motor	R32	R33	R34	R35
L1 Max	180.1 (7.09)	205.5 (8.09)	230.9 (9.09)	256.3 (10.09)
L2	142.7 (5.62)	168.1 (6.62)	193.5 (7.62)	218.9 (8.62)

mm (in.)

R40 SERIES MOTOR — 4.25" width/height (square frame)

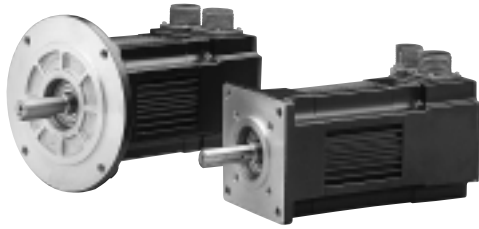

- 4-pole synchronous servomotors
- Samarium-cobalt permanent magnets for maximum torque-to-inertia without demagnetization
- Low rotor inertia for rapid accel/decel
- 240V ac, 320V dc bus operation
- Anti-cog stator design
- Rated speeds to 5,300 RPM

The R40 Series motors cover a continuous torque range from 3.9 to 7.6 Nm. These motors are characterized by smooth operation at low speeds, rapid acceleration and deceleration, and high torque production throughout a wide speed range.

RATINGS AND CHARACTERISTICS

Motor parameters and winding data. See system data beginning on page 4 for typical torque/speed performance.

PARAMETER	SYMBOL	UNITS	R43		R45		R46	
Continuous stall torque ^①	T _{CS}	Nm (lb.-in.)	3.9 (34.5)		5.7 (50.4)		7.6 (67.3)	
Peak torque ^④	T _{PK}	Nm (lb.-in.)	10.4 (92.1)		15.1 (134)		20.2 (179)	
Inertia ^③	J _M	kgm ² x10 ⁻³ (lb.-in.-sec ² x10 ⁻³)	.22 (1.98)		.31 (2.78)		.40 (3.58)	
Static friction (max.)	T _f	Nm (lb.-in.)	0.03 (0.26)		0.04 (0.33)		0.04 (0.39)	
Viscous damping coefficient	K _{GV}	Nm/kRPM (lb.-in./kRPM)	0.011 (0.10)		0.016 (0.14)		0.019 (0.17)	
Thermal resistance ^⑤	R _{TH}	deg. C/Watt	0.72		0.61		0.52	
Thermal time constant	τ _{TH}	min.	19.0		29.0		35.0	
Weight (motor only)	W	kg (lbs.)	6.8 (15.0)		9.1 (20.0)		11.3 (25.0)	
WINDING DATA			G	H	G	H	G	H
Torque constant (RMS) ^②	K _t	Nm/A _{RMS} (lb.-in./A _{RMS})	1.3 (11.5)	0.7 (6.2)	1.0 (8.9)	0.5 (4.4)	1.4 (12.4)	0.7 (6.2)
Voltage constant (RMS) ^②	K _e	V _{RMS} /rad/sec (V _{RMS} /kRPM)	0.79 (82.7)	0.43 (45.0)	0.61 (63.9)	0.30 (31.4)	0.85 (89.0)	0.43 (45.0)
Continuous stall current ^①	I _{CS}	A _{RMS}	2.9	5.6	5.5	10.9	5.5	11.0
Current at peak torque ^④	I _{PK}	A _{RMS}	8.7	16.8	16.5	32.7	16.5	33.0
Resistance (line-to-line)	R _c	Ohms	10.0	2.5	3.2	0.81	3.7	0.93
Inductance (line-to-line)	L	mH	53.0	13.3	20.0	4.9	25.0	6.2
Typical Rated Speed @ 240V ac, 320V dc bus	W _R	RPM	1,500	3,700	2,400	5,300	1,700	4,000
Typical Rated Torque @240V ac, 320V dc bus	T _{CR}	Nm (lb.-in.)	3.9 (34.6)	3.6 (31.7)	5.5 (48.5)	4.7 (41.9)	7.3 (64.6)	5.7 (50.3)

Metric Mount Shown — also available in NEMA and English mount. Consult factory or website for details.

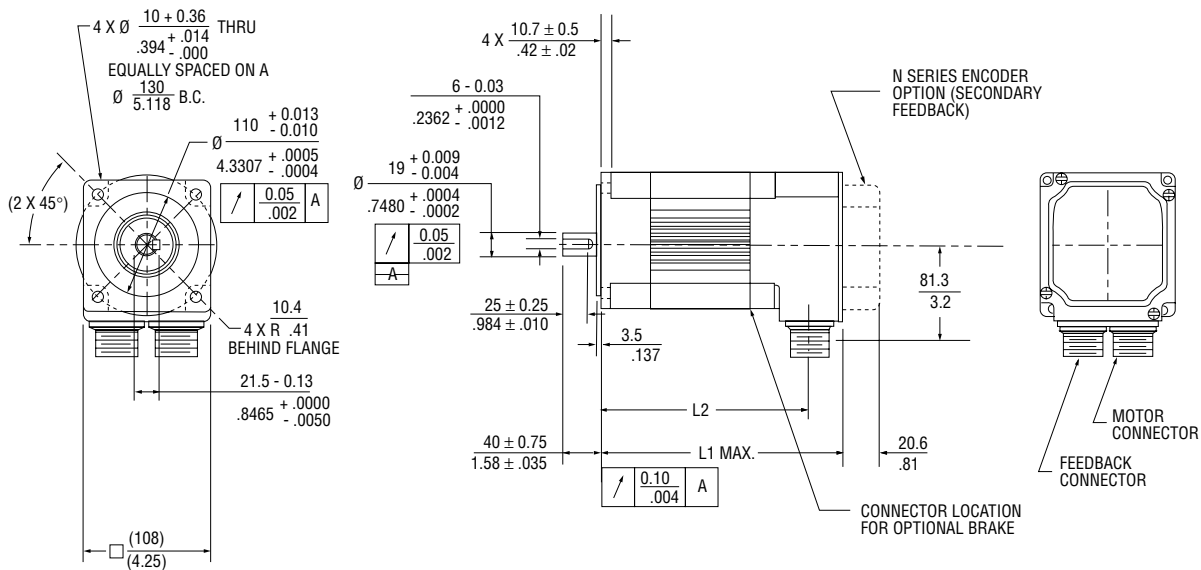

Note: All values at 25°C unless otherwise noted.

- ① Windings at 155°C. Motor in 25°C ambient and mounted to a 10" x 10" x 1/4" aluminum heat sink.
- ② RMS value of a sinusoidal waveform, measured line to neutral.
- ③ Motor with resolver feedback.
- ④ Caution: For peak torques or peak currents greater than 3x the continuous rating, consult the factory for thermal considerations.
- ⑤ Motor in 25°C ambient, mounted to a 10" x 10" x 1/4" aluminum heat sink.

Motor	R43	R45	R46
L1 Max	213.4 (8.4)	251.5 (9.9)	289.6 (11.4)
L2	178.1 (7.01)	216.2 (8.51)	254.3 (10.01)

mm (in.)

R60 SERIES MOTOR — 5.75" width/height (square frame)



- 4-pole synchronous servomotors
- Samarium-cobalt permanent magnets for maximum torque-to-inertia without demagnetization
- Low rotor inertia for rapid accel/decel
- 240V ac, 320V dc bus operation
- Anti-cog stator design
- Rated speeds to 6,000 RPM

The R60 Series motors cover a continuous torque range from 8.3 to 19.9 Nm. Built for heavy duty applications, these motors deliver excellent torque, speed and/or velocity control.

RATINGS AND CHARACTERISTICS

Motor parameters and winding data. See system data beginning on page 4 for typical torque/speed performance.

PARAMETER	SYMBOL	UNITS	R63		R65		R67	
Continuous stall torque ^①	T _{CS}	Nm (lb.-in.)	8.3 (73.5)		13.6 (120)		19.9 (176)	
Peak torque ^②	T _{PK}	Nm (lb.-in.)	20.5 (181)		33.3 (295)		48.9 (433)	
Inertia ^③	J _M	kgm ² x10 ⁻³ (lb.-in.-sec ² x10 ⁻³)	.81 (7.2)		1.26 (11.2)		1.72 (15.2)	
Static friction (max.)	T _f	Nm (lb.-in.)	0.16 (1.4)		0.26 (2.3)		0.36 (3.2)	
Viscous damping coefficient	K _{SV}	Nm/kRPM (lb.-in./kRPM)	0.046 (0.41)		0.075 (0.66)		0.104 (0.92)	
Thermal resistance ^④	R _{TH}	deg. C/Watt	0.51		0.42		0.30	
Thermal time constant	τ _{TH}	min.	19.0		36.0		72.0	
Weight (motor only)	W	kg (lbs.)	13.0 (29.0)		18.0 (39.0)		22.0 (49.0)	
WINDING DATA								
			G	H	G	H	G	H
Torque constant (RMS) ^⑤	K _T	Nm/A _{RMS} (lb.-in./A _{RMS})	0.8 (7.1)	0.4 (3.5)	1.3 (11.5)	0.6 (5.3)	1.8 (15.9)	0.9 (8.0)
Voltage constant (RMS) ^⑤	K _E	V _{RMS} /rad/sec (V _{RMS} /kRPM)	0.49 (51.3)	0.24 (25.1)	0.79 (82.7)	0.36 (37.7)	1.09 (114)	0.55 (57.6)
Continuous stall current ^①	I _{CS}	A _{RMS}	11.0	22.0	10.7	21.4	11.3	22.5
Current at peak torque ^②	I _{PK}	A _{RMS}	33.0	66.0	32.1	64.2	33.9	67.5
Resistance (line-to-line)	R _C	Ohms	0.93	0.23	1.20	0.34	1.50	0.37
Inductance (line-to-line)	L	mH	8.9	2.2	13.7	3.40	18.2	4.60
Typical Rated Speed @240V ac, 320V dc bus	W _R	RPM	3,400	6,000	2,000	4,300	1,400	3,000
Typical Rated Torque @ 240V ac, 320V dc bus	T _{CR}	Nm (lb.-in.)	6.8 (60.1)	4.4 (39.3)	12.2 (108)	9.9 (87.6)	17.6 (156)	15.7 (139)

Metric Mount Shown — also available in English mount. Consult factory or website for details.

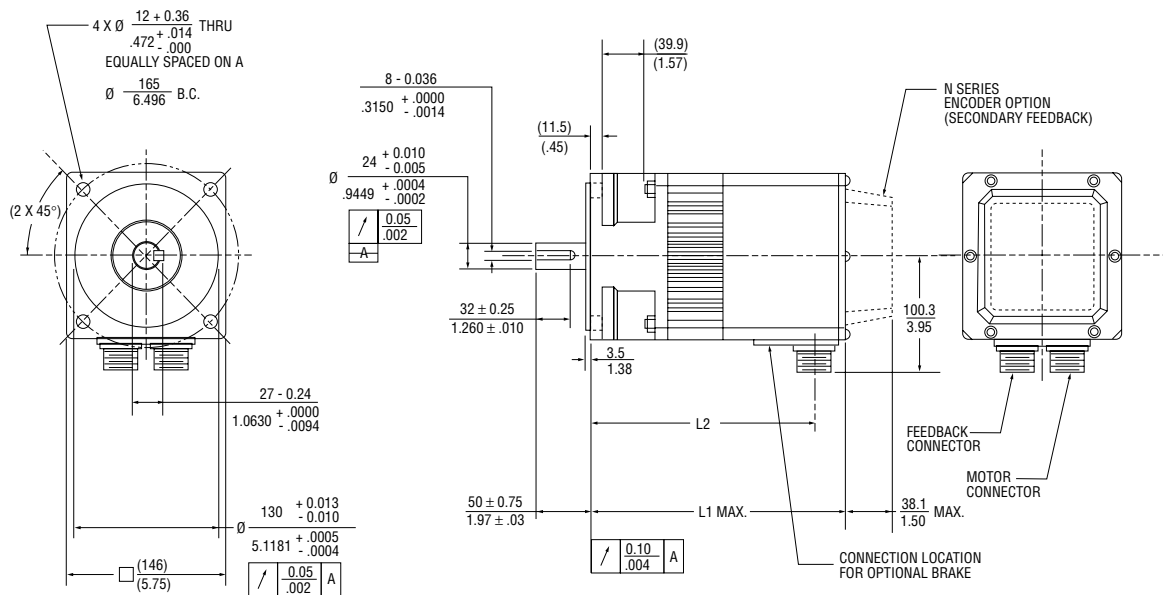

Note: All values at 25°C unless otherwise noted.

- ① Windings at 155°C. Motor in 25°C ambient and mounted to a 18" x 18" x 1/2" aluminum heat sink.
- ② RMS value of a sinusoidal waveform, measured line to neutral.
- ③ Motor with resolver feedback.
- ④ Caution: For peak torques or peak currents greater than 3x the continuous rating, consult the factory for thermal considerations.
- ⑤ Motor in 25°C ambient, mounted to a 18" x 18" x 1/2" aluminum heat sink.

Motor	R63	R65	R67
L1 Max	237.7 (9.36)	288.5 (11.36)	339.3 (13.36)
L2	206.2 (8.12)	257 (10.12)	307.8 (12.12)

mm (in.)

R80 SERIES MOTOR — 7.5" width/height (square frame)



- 4-pole synchronous servomotors
- Samarium-cobalt permanent magnets for maximum torque-to-inertia without demagnetization
- Low rotor inertia for rapid accel/decel
- 240V ac, 320V dc bus operation
- Anti-cog stator design
- Rated speeds to 4,000 RPM

The R80 Series motors cover a continuous torque range from 22.5 to 53.4 Nm. Providing excellent torque, speed and/or velocity control, they are built for extremely high torque and power applications.

RATINGS AND CHARACTERISTICS

Motor parameters and winding data. See system data beginning on page 4 for typical torque/speed performance.

PARAMETER	SYMBOL	UNITS	R84		R86		R88		R8A	
Continuous stall torque ^①	T _{CS}	Nm (lb.-in.)	22.5 (199)		32.7 (289)		42.2 (374)		53.4 (473)	
Peak torque ^②	T _{PK}	Nm (lb.-in.)	44.5 (394)		66.6 (590)		86.1 (762)		109 (961)	
Inertia ^③	J _M	kgm ² x10 ⁻³ (lb.-in.-sec ² x10 ⁻³)	4.43 (39.2)		6.57 (58.2)		8.61 (76.2)		10.8 (95.2)	
Static friction (max.)	T _f	Nm (lb.-in.)	0.28 (2.5)		0.42 (3.7)		0.56 (5.0)		0.70 (6.3)	
Viscous damping coefficient	K _{DV}	Nm/kRPM (lb.-in./kRPM)	0.11 (0.96)		0.16 (1.4)		0.20 (1.8)		0.25 (2.2)	
Thermal resistance ^⑤	R _{TH}	deg. C/Watt	0.30		0.25		0.23		0.21	
Thermal time constant	τ _{TH}	min.	40.0		54.0		59.0		63.0	
Weight (motor only)	W	kg (lbs.)	27.0 (60.0)		35.0 (77.0)		43.0 (94.0)		49.0 (111)	
WINDING DATA			G	H	G	H	G	H	G	H
Torque constant (RMS) ^②	K _t	Nm/A _{RMS} (lb.-in./A _{RMS})	0.8 (7.1)	0.4 (3.5)	1.1 (9.7)	0.5 (4.4)	1.4 (12.4)	0.7 (6.2)	2.2 (19.5)	1.1 (9.7)
Voltage constant (RMS) ^②	K _e	V _{RMS} /rad/sec (V _{RMS} /kRPM)	0.49 (51.3)	0.24 (25.1)	0.67 (70.2)	0.30 (31.4)	0.85 (89.0)	0.43 (45.0)	1.34 (140)	0.67 (70.2)
Continuous stall current ^①	I _{CS}	A _{RMS}	26.9	53.9	30.2	60.4	29.4	59.6	24.5	49.0
Current at peak torque ^②	I _{PK}	A _{RMS}	80.7	162	90.6	181	88.2	179	73.5	147
Resistance (line-to-line)	R _c	Ohms	0.26	0.07	0.25	0.06	0.28	0.07	0.46	0.12
Inductance (line-to-line)	L	mH	3.2	0.8	3.6	0.9	4.0	1.0	7.4	1.9
Typical Rated Speed @ 240V ac, 320V dc bus	W _R	RPM	3,300	4,000	2,500	3,500	1,900	3,500	1,200	2,600
Typical Rated Torque @ 240V ac, 320V dc bus	T _{CR}	Nm (lb.-in.)	17.4 (154)	10.1 (89.7)	23.5 (208)	16.6 (147)	36.8 (326)	20.5 (181)	48.6 (430)	26.8 (237)

Metric Mount Shown — also available in English mount. Consult factory or website for details.

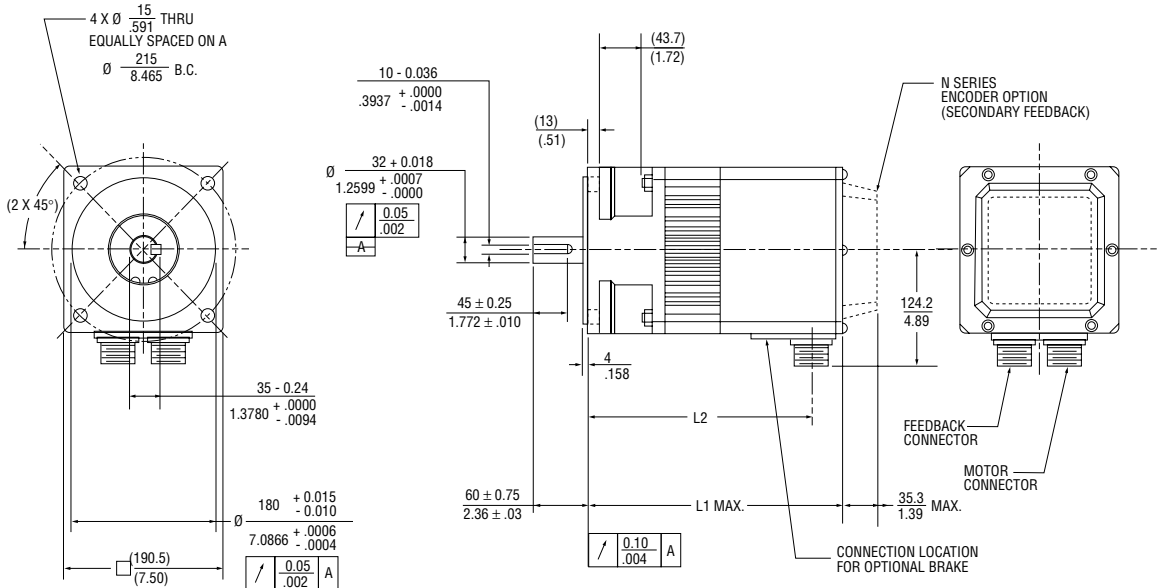

Note: All values at 25°C unless otherwise noted.

- ① Windings at 155°C. Motor in 25°C ambient and mounted to a 18" x 18" x 1/2" aluminum heat sink.
- ② RMS value of a sinusoidal waveform, measured line to neutral.
- ③ Motor with resolver feedback.
- ④ Caution: For peak torques or peak currents greater than 3x the continuous rating, consult the factory for thermal considerations.
- ⑤ Motor in 25°C ambient, mounted to a 18" x 18" x 1/2" aluminum heat sink.

Motor	R84	R86	R88	R8A
L1 Max	277.6 (10.93)	328.4 (12.93)	379.2 (14.93)	430.0 (16.93)
L2	242.8 (9.56)	293.6 (11.56)	344.4 (13.56)	395.2 (15.56)

mm (in.)

R30P SERIES MOTOR — 3.25" width/height (square frame)



UL Listed file US E150845 UL/cUL
Meets Cenelec requirements
cert. no. 99E 9844204 EE. dIIB

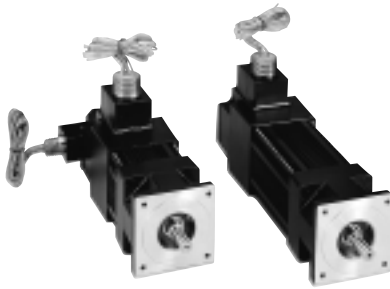

- 4-pole synchronous servomotors
- Samarium-cobalt permanent magnets for maximum torque-to-inertia without demagnetization
- Low rotor inertia for rapid accel/decel
- 240V ac, 320V dc bus operation
- Anti-cog stator design
- UL Listed, file 150845. Meets UL Division 1, Class 1, Groups C & D
- Meets Cenelec requirements of EN 50014-1992.

- Built-in thermostat
- Rated speeds to 7,000 RPM

R30P Series Explosion Proof motors cover a continuous torque range from 1.3 to 3.1 Nm. These compact motors are well-suited for speed and position control applications that require maximum performance in minimum space — wherever hazardous conditions are present.

RATINGS AND CHARACTERISTICS

Motor parameters and winding data. See system data beginning on page 4 for typical torque/speed performance.

PARAMETER	SYMBOL	UNITS	R32P	R33P	R34P	R35P				
Continuous stall torque ^①	T _{CS}	Nm (lb.-in.)	1.3 (11.5)	2.0 (17.7)	2.6 (23.0)	3.1 (27.4)				
Peak torque ^②	T _{PK}	Nm (lb.-in.)	3.70 (32.8)	5.31 (47.0)	6.90 (61.1)	8.31 (73.5)				
Inertia ^③	J _M	kgm ² x10 ⁻³ (lb.-in.-sec ² x10 ⁻³)	.071 (.63)	.093 (.82)	.11 (1.00)	.13 (1.19)				
Static friction (max.)	T _f	Nm (lb.-in.)	0.03 (0.23)	0.04 (0.31)	0.04 (0.39)	0.05 (0.47)				
Viscous damping coefficient	K _{DV}	Nm/kRPM (lb.-in./kRPM)	0.005 (0.04)	0.007 (0.06)	0.010 (0.09)	0.012 (0.11)				
Thermal resistance ^④	R _{TH}	deg. C/Watt	0.93	0.84	0.76	0.70				
Thermal time constant	τ _{TH}	min.	20.0	23.0	26.0	29.0				
Weight (motor only)	W	kg (lbs.)	2.5 (5.5)	3.2 (7.1)	3.9 (8.7)	4.6 (10.2)				
WINDING DATA										
			G	H	G	H	J	K	J	K
Torque constant (RMS) ^⑤	K _t	Nm/A _{RMS} (lb.-in./A _{RMS})	0.6 (5.3)	0.3 (2.7)	0.8 (7.1)	0.4 (3.5)	1.0 (8.9)	0.5 (4.4)	1.2 (10.6)	0.6 (5.3)
Voltage constant (RMS) ^⑤	K _e	V _{RMS} /rad/sec (V _{RMS} /kRPM)	0.36 (37.7)	0.18 (18.8)	0.49 (61.3)	0.24 (25.1)	0.61 (63.9)	0.30 (31.4)	0.73 (76.4)	0.36 (37.7)
Continuous stall current ^⑤	I _{CS}	A _{RMS}	2.5	4.8	2.6	5.2	2.5	5.1	2.5	4.9
Current at peak torque ^⑤	I _{PK}	A _{RMS}	7.3	14.4	7.8	15.6	7.5	15.3	7.5	14.7
Resistance (line-to-line)	R _c	Ohms	7.3	1.8	6.9	1.7	8.1	2.0	9.2	2.3
Inductance (line-to-line)	L	mH	23.0	5.8	22.0	5.6	30.0	7.5	42.0	10.5
Typical Rated Speed @ 240V ac, 320V dc bus	W _R	RPM	4,500	7,000	3,500	7,000	2,600	5,700	1,900	4,500
Typical Rated Torque @ 240V ac, 320V dc bus	T _{CR}	Nm (lb.-in.)	0.9 (8.3)	0.62 (5.5)	1.5 (13.4)	0.9 (7.6)	2.3 (20.6)	1.4 (12.5)	3.0 (26.5)	2.0 (17.4)

Metric Mount Shown — also available in English mount. Consult factory or website for details.

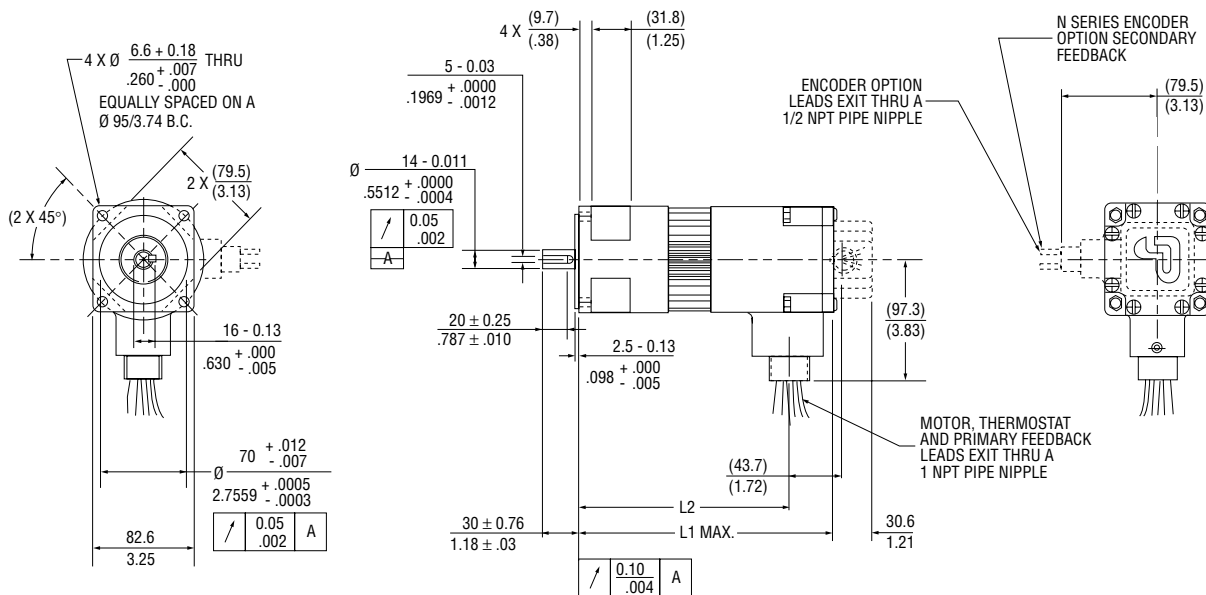

Note: All values at 25°C unless otherwise noted.

- ① Windings at 155°C. Motor in 25°C ambient and mounted to a 10" x 10" x 1/4" aluminum heat sink.
- ② RMS value of a sinusoidal waveform, measured line to neutral.
- ③ Motor with resolver feedback.
- ④ Caution: For peak torques or peak currents greater than 3x the continuous rating, consult the factory for thermal considerations.
- ⑤ Motor in 25°C ambient, mounted to a 10" x 10" x 1/4" aluminum heat sink.

Motor	R32	R33	R34	R35
L1 Max	214.6 (8.45)	240.0 (9.45)	265.4 (10.45)	290.8 (11.45)
L2	173.0 (6.81)	198.4 (7.81)	223.8 (8.81)	249.2 (9.81)

mm (in.)

R60P SERIES MOTOR — 5.75" width/height (square frame)



UL Listed file US E150845 UL/cUL
Meets Cenelec requirements
cert. no. 99E 9844204 EE. dIIB

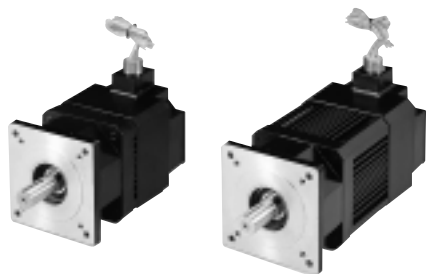

- 4-pole synchronous servomotors
- Samarium-cobalt permanent magnets for maximum torque-to-inertia without demagnetization
- Low rotor inertia for rapid accel/decel
- 240V ac, 320V dc bus operation
- Anti-cog stator design
- UL Listed, file 150845. Meets UL Division 1, Class 1, Groups C & D
- Meets Cenelec requirements of EN 50014-1992.

- Built-in thermostat
- Rated speeds to 6,000 RPM

The R60P Series motors cover a continuous torque range from 8.3 to 19.9 Nm. Built for heavy duty applications, these motors deliver excellent torque, speed and/or velocity control, wherever hazardous conditions are present.

RATINGS AND CHARACTERISTICS

Motor parameters and winding data. See system data beginning on page 4 for typical torque/speed performance.

PARAMETER	SYMBOL	UNITS	R63P	R65P	R67P			
Continuous stall torque ^①	T _{CS}	Nm (lb.-in.)	6.8 (60.2)	11.2 (99.1)	15.9 (141)			
Peak torque ^②	T _{PK}	Nm (lb.-in.)	16.6 (147)	27.8 (246)	40.0 (354)			
Inertia ^③	J _M	kgm ² x10 ⁻³ (lb.-in.-sec ² x10 ⁻³)	.81 (7.2)	1.26 (11.2)	1.72 (15.2)			
Static friction (max.)	T _f	Nm (lb.-in.)	0.16 (1.4)	0.26 (2.3)	0.36 (3.2)			
Viscous damping coefficient	K _{OV}	Nm/kRPM (lb.-in./kRPM)	0.05 (0.41)	0.08 (0.66)	0.10 (0.92)			
Thermal resistance ^⑤	R _{TH}	deg. C/Watt	0.51	0.42	0.30			
Thermal time constant	τ _{TH}	min.	19.0	36.0	72.0			
Weight (motor only)	W	kg (lbs.)	13.0 (29.0)	18.0 (39.0)	22.0 (49.0)			
WINDING DATA								
			G	H	G	H		
Torque constant (RMS) ^②	K _T	Nm/A _{RMS} (lb.-in./A _{RMS})	0.7 (6.2)	0.4 (3.5)	1.2 (10.6)	0.6 (5.3)	1.7 (15.0)	0.9 (8.0)
Voltage constant (RMS) ^②	K _E	V _{RMS} /rad/sec (V _{RMS} /kRPM)	0.43 (45.0)	0.24 (25.1)	0.73 (76.4)	0.36 (37.7)	1.03 (108)	0.55 (57.6)
Continuous stall current ^①	I _{CS}	A _{RMS}	9.1	18.2	9.4	17.7	9.3	18.6
Current at peak torque ^④	I _{PK}	A _{RMS}	27.3	54.6	28.3	53.0	27.9	54.8
Resistance (line-to-line)	R _C	Ohms	0.93	0.23	1.20	0.34	1.5	0.37
Inductance (line-to-line)	L	mH	8.9	2.2	13.7	3.4	18.2	4.6
Typical Rated Speed @240V ac, 320V dc bus	W _R	RPM	3,600	6,000	2,100	4,500	1,500	3,200
Typical Rated Torque @ 240V ac, 320V dc bus	T _{CR}	Nm (lb.-in.)	65.5 (48.9)	3.6 (32.2)	9.9 (87.9)	9.0 (80.0)	14.4 (127)	12.8 (113)

Metric Mount Shown — also available in English mount. Consult factory or website for details.

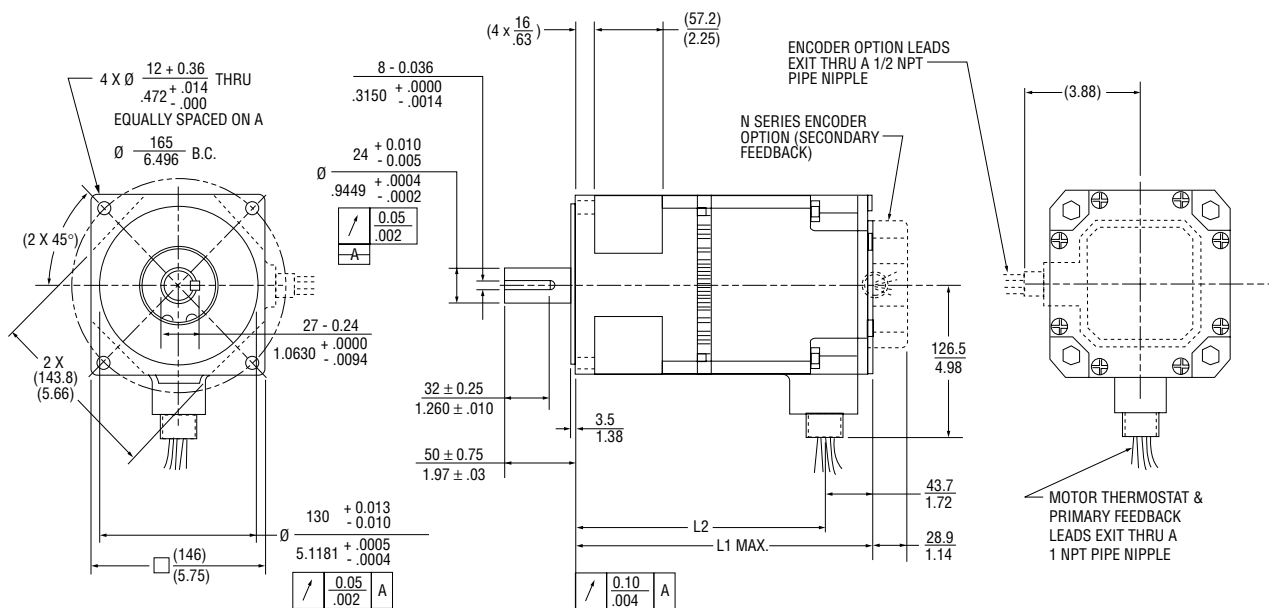

Note: All values at 25°C unless otherwise noted.

- ① Windings at 155°C. Motor in 25°C ambient and mounted to a 18" x 18" x 1/2" aluminum heat sink.
- ② RMS value of a sinusoidal waveform, measured line to neutral.
- ③ Motor with resolver feedback.
- ④ Caution: For peak torques or peak currents greater than 3x the continuous rating, consult the factory for thermal considerations.
- ⑤ Motor in 25°C ambient, mounted to a 18" x 18" x 1/2" aluminum heat sink.

Motor	R63	R65	R67
L1 Max	254.8 (10.03)	305.6 (12.03)	356.4 (14.03)
L2	211.6 (8.33)	262.4 (10.33)	313.2 (12.33)

mm (in.)

PRIMARY FEEDBACK DEVICES

Primary Feedback Devices			Secondary Feedback Devices
PMA Series Resolver Commutating Encoder SinCos Encoder	PMB Series Resolver Hall Effect Sensors Commutating Encoder	S Series, R Series Resolver Hall Effect Sensors	S Series, R Series Encoder

A selection of feedback combinations are available for the PMA, S Series and R Series motors. Options for the PMA Series include resolver, commutating encoder and SinCos encoder. The R and S Series offers either resolver or Hall effect sensors as primary feedback, and an encoder as a secondary feedback device. The PMA, R Series and S Series motors all use a resolver as feedback for system use with the PC800 and SC/SCE900 Series Drives.

FRAMELESS RESOLVERS (R)

Frameless Resolvers for the PMA and S Series motors

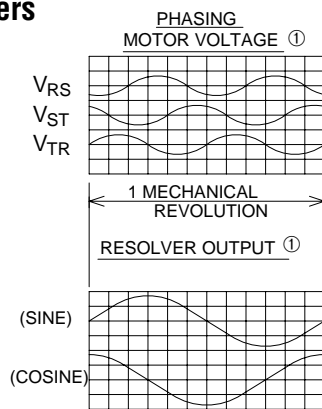

Typical output @ 25°C

Parameter	Units	PMA Series		S Series
		21	15	21
Frame size		21	15	21
Type		Transmitter	Transmitter	Transmitter
Primary		Rotor	Rotor	Rotor
Speed		1	1	1
Input voltage	V_{RMS}	7.0	7.0	4.0
Frequency	kHz	10	10	5
Input current, max.	mA	50	65	25
Transformation ratio		0.5	0.5	0.5
Max. electrical error	Minutes	10	10	21
Rotor inertia, max.	kgm^2	12.3×10^{-6}	3×10^{-6}	20.3×10^{-6}
Weight	kg	0.22	0.06	0.21

① For clockwise motor rotation.

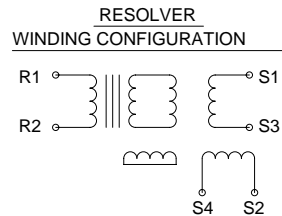

FRAMELESS RESOLVERS (R1, R2, PMB SERIES)

Frameless Resolvers for the R Series, PMB Series motors

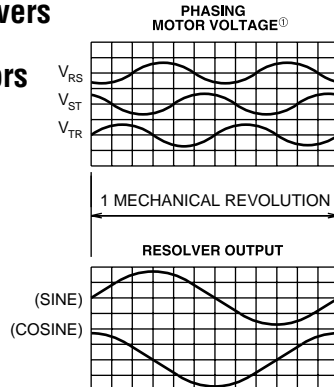

Typical output @ 25°C

Parameter	Units	R1	R2	PMB
		15	21	15
Frame size		15	21	15
Type		Transmitter	Transmitter	Transmitter
Primary		Rotor	Rotor	Rotor
Speed		1	1	1
Input voltage	V_{RMS}	4.0	4.0	7.0
Frequency	kHz	5	5	4.3
Input current, max.	mA	25	25	100
Transformation ratio		0.5	0.5	0.5
Max. electrical error	Minutes	± 15	± 21	± 10
Rotor inertia Max.	$kgm^2 \times 10^{-6}$	2.8	1.7	2.6
Weight	kg	0.13	0.25	0.074

① For clockwise motor rotation.

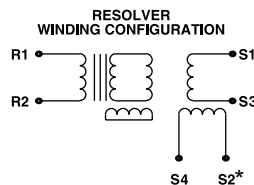

* Note: S2 & S4 reversed for PMB Series motors.

PRIMARY FEEDBACK DEVICES

PRIMARY FEEDBACK DEVICES...TECHNICAL DATA

Hall Sensors for S Series motors

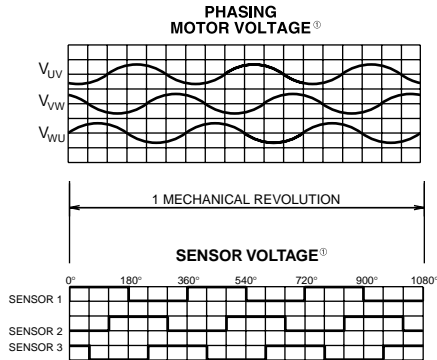

Typical output @ 25°C

Parameter	Units	Value
Commutation outputs:		See phasing diagram
No. of poles		6
No. of phases		3
Output volts, max.	volts	DC Supply
Power supply required	volts	+ 4.5 to 24 VDC
	mA	20 mA max
Rotor inertia	kgm ² x 10 ⁻⁶	5.5
Weight	kg	.03

① For clockwise motor rotation.

PRIMARY FEEDBACK DEVICES...TECHNICAL DATA

Hall Sensors for R Series, PMB1

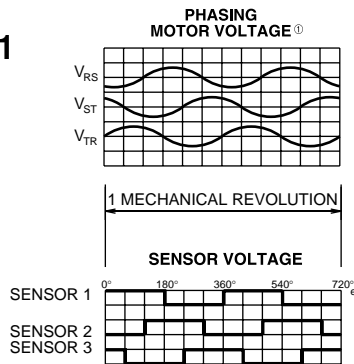

Typical performance @ 25°C

Parameter	Units	Value
Commutation outputs:		See phasing diagram
No. of poles		4
No. of phases		3
Output volts, max.	volts	DC Supply
Power supply required	volts	+ 4.5 to 24 VDC
	mA	20 mA max
Rotor inertia	kgm ²	1.81 x 10 ⁻⁶ — R20 series, PMB1 5.53 x 10 ⁻³ — All other series
Weight	kg	0.014 — R20 series 0.036 — All other series

① For clockwise motor rotation.

PRIMARY FEEDBACK DEVICES...TECHNICAL DATA

Hall Sensors for PMB2, 3 Series

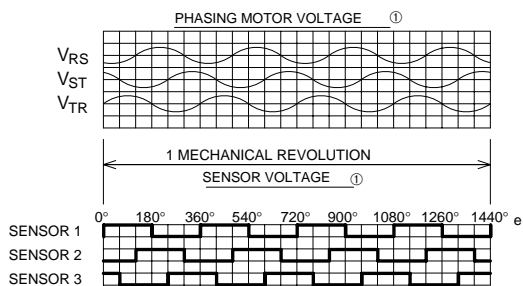

Typical performance @ 25°C

Hall Sensor Data	Units	PMB Series
Number of poles		8
Number of phases		3
Input voltage	VDC	+4 to 24
Input current	mA max.	30
Maximum output voltage	DC Supply	DC Supply
Rotor inertia	kgm ²	1.8 x 10 ⁻⁶

① For clockwise motor rotation.

BRUSHLESS SERVO MOTOR FEEDBACK COMBINATIONS

PMA SERIES WITH COMMUTATION ENCODER OPTION

RECOMMENDED OUTPUT CIRCUITRY

● Standard Type

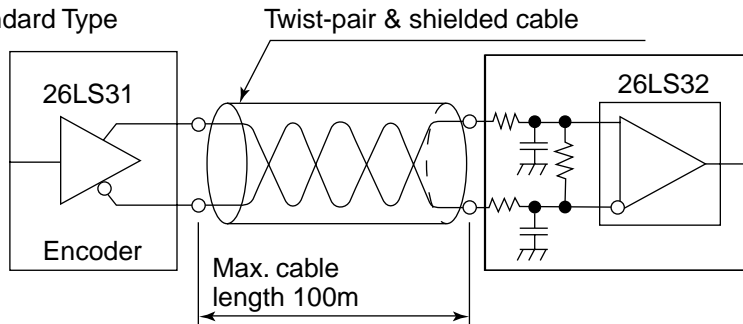

OUTPUT PHASE SHIFT

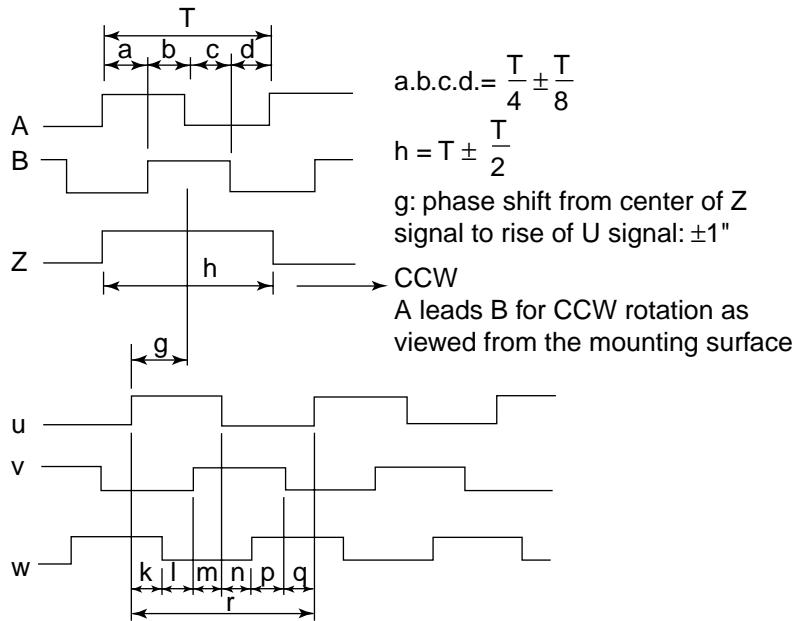

No. of Poles	k,l,m,n,p,q	r
4	$30^\circ \pm 1.5'$	180°
6	$20^\circ \pm 1.5'$	120°
8	$1.5^\circ \pm 1.5'$	90°

Specifications

Resolution	1024 or 2048 line count
Input voltage	5V dc $\pm 5\%$
Input current	200 mA max.
Output Circuit	Line driver 26LS31 (26C31) Source current: 20 mA max. Sink current: 20 mA max.
Frequency response	200 kHz max. (up to 85°C) 100 kHz max. (up to 100°C)
Rise and fall time	100 nSec. max.
Inertia	6.5×10^{-6} kgm ² max.
Max speed	6,000 rpm
Weight	0.3 kg max.

BRUSHLESS SERVO MOTOR FEEDBACK COMBINATIONS

PMB SERIES WITH COMMUTATION ENCODER OPTION

RECOMMENDED OUTPUT CIRCUITRY

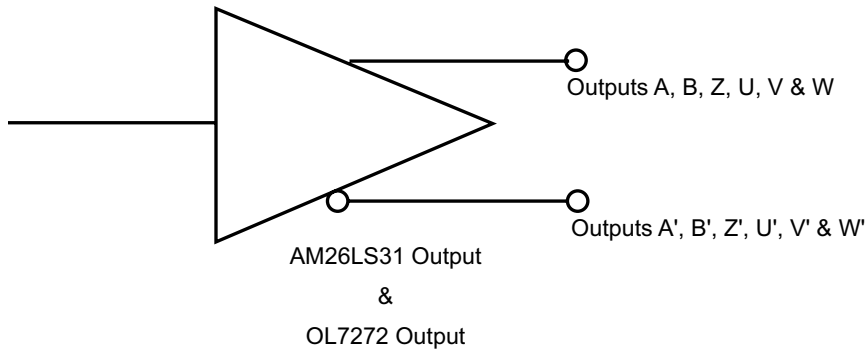

OUTPUT PHASE SHIFT

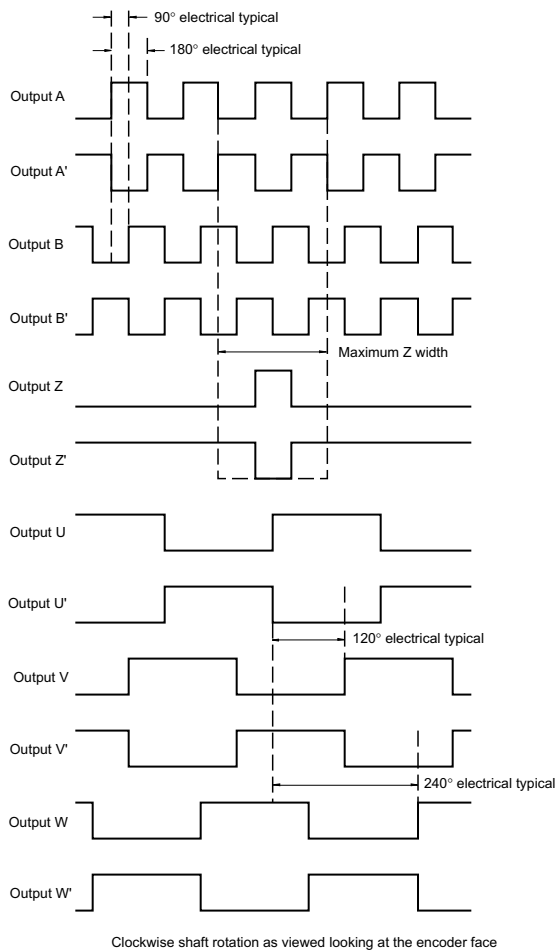

Specifications

Resolution	2048 or 4096 line count
Input voltage	5V dc $\pm 5\%$
Input current	100 mA max.
Output Circuit	Line driver AM26LS31 RS422A OL7272 high voltage line driver TTL output
Frequency response	200 kHz
Commutation accuracy	-1; mechanical
Inertia	1.5×10^{-4} oz-in-S ²
Max speed	8,000 rpm

BRUSHLESS SERVO MOTOR FEEDBACK COMBINATIONS

PMA SERIES WITH SINCOS ENCODER OPTION

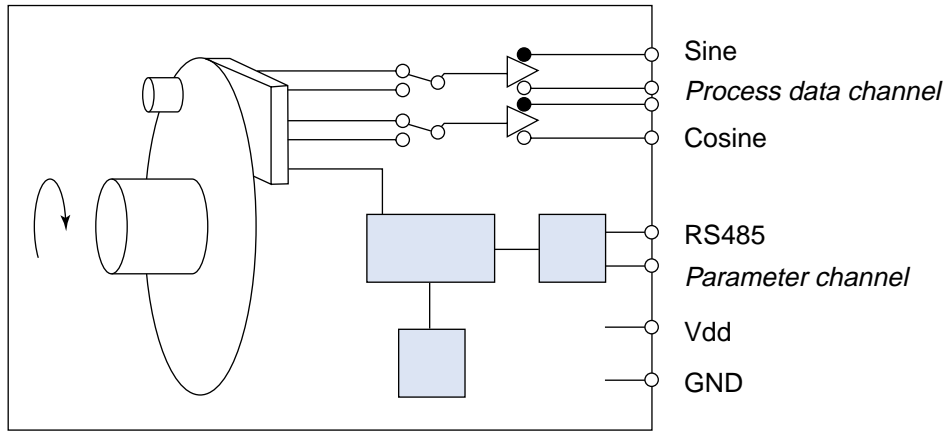

In the SinCos encoder, the interface to the motor controller consists of a process data channel and a parameter channel. The SinCos encoder uses the following basic internal information:

1. A sine/cosine signal with 1024 cycles per revolution.
2. A sine/cosine signal with one cycle per revolution.
3. A reference signal (REF) which appears once per revolution with a length of $<1/1024$ revolution. The reference pulse is transmitted via the microcontroller RS485 interface. When operating the encoder at the maximum frequency, a misalignment of the reference pulse of up to 1 increment may occur.

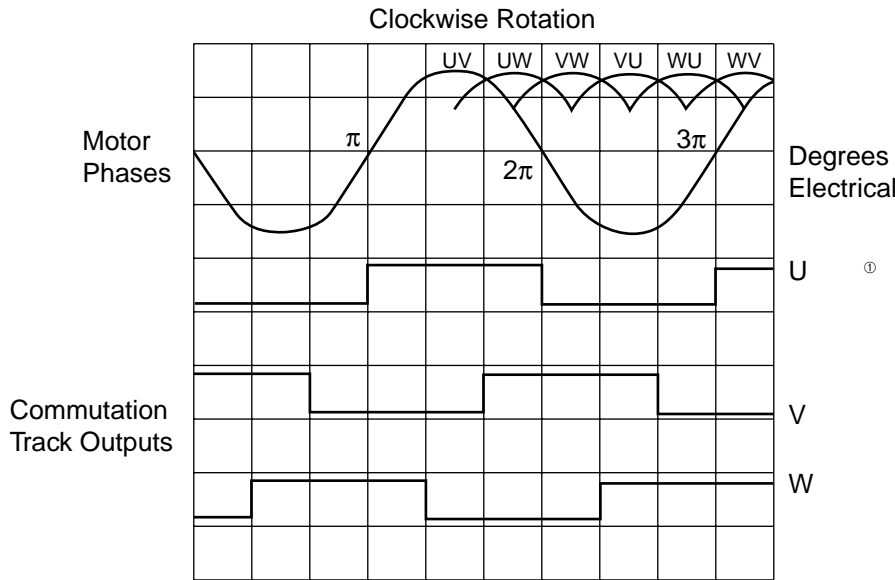

Max. misalignment between rising edge of commutation track U & zero crossing of back EMF UV $\leq 3^\circ$ electrical.

Specifications

Resolution	1024 line count
Input voltage	8V dc
Input current	100 mA max.
Frequency response	100 kHz max. (up to 100°C)
Rise and fall time	100 nSec. max.
Inertia	1.0×10^{-6} kgm ² max.
Max speed	9,000 rpm
Weight	0.1 kg

Motor Connections

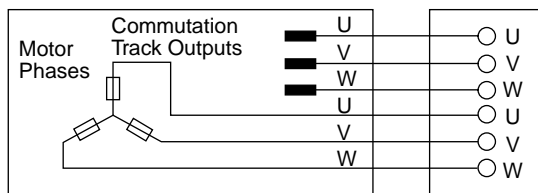

When using the SinCos encoder for primary feedback, Pacific Scientific recommends a 10% derating of motor performance specifications to avoid overheating the encoder.

S SERIES BRUSHLESS SERVO MOTOR FEEDBACK COMBINATIONS

S SERIES MOTORS SECONDARY FEEDBACK DEVICES...TECHNICAL DATA

OPTICAL ENCODERS

Typical performance @ 25°C

S20 SERIES, NEMA 23 Frame

Parameter	F	G
Pulses per revolution	1000	1024
Type	Incremental	
Supply voltage	+5V dc $\pm 10\%$ @ 160 mA typical	
Output format	Dual-channel quadrature and index with complements	
Output type	26LS31 TTL Differential Line Driver (RS422A)—short-circuit protected	
Frequency response	125 kHz	
Rotor inertia	1.5×10^{-6} kgm ²	
Weight	.08 kg	

S30 SERIES, NEMA 34 Frame

Parameter	F	G
Pulses per revolution	1000	1024
Type	Incremental	
Supply voltage	+5V dc $\pm 10\%$ @ 165 mA typical	
Output format	Dual-channel quadrature and index with complements	
Output type	26LS31 TTL Differential Line Driver (RS422A)—short-circuit protected	
Frequency response	100 kHz	
Rotor inertia	$.75 \times 10^{-6}$ kgm ²	
Weight	①.08 kg	

① Includes weight of additional end cover.

OPTICAL ENCODERS (LA, LB, LC, ND, NF, NG)

Typical performance @ 25°C

Parameter	LA	LB	LC
Pulses per revolution	500	1000	1024
Type	Incremental		
Supply voltage	+5V dc $\pm 5\%$ @ 160 mA typical		
Output format	Dual-channel quadrature and index with complements		
Output type	26LS31 TTL Differential Line Driver (RS422A)—short-circuit protected		
Frequency response	125 kHz		
Rotor inertia	2.82×10^{-6} kgm ²		

Parameter	ND	NF	NG
Pulses per revolution	500	1000	1024
Type	Incremental		
Supply voltage	+5V dc $\pm 5\%$ @ 160 mA typical		
Output format	Dual-channel quadrature and index with complements		
Output type	26LS31 TTL Differential Line Driver (RS422A)—short-circuit protected		
Frequency response	125 kHz		
Rotor inertia	1.58×10^{-6} kgm ²		

ENCODER OUTPUT

FOR CW DIRECTION OF ROTATION WHEN VIEWED FROM DRIVE SHAFT END (COMPLEMENTS NOT SHOWN)

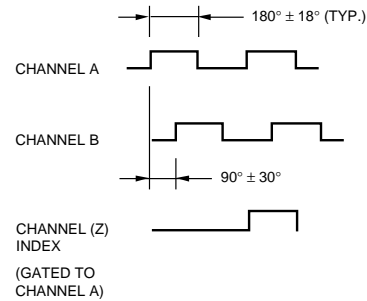

FOR CW DIRECTION OF ROTATION WHEN VIEWED FROM DRIVE SHAFT END (COMPLEMENTS NOT SHOWN)

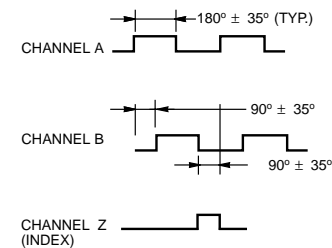

ENCODER OUTPUT

L and N Types

FOR CW DIRECTION OF ROTATION WHEN VIEWED FROM DRIVE SHAFT END (COMPLEMENTS NOT SHOWN)

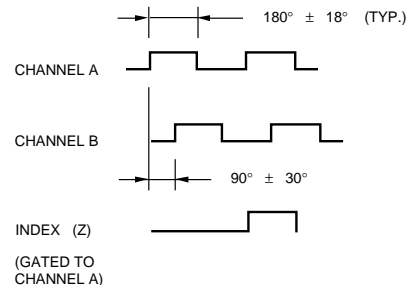

PHASING DIAGRAM—ALL MOTORS

Shown here is the phasing diagram for CW rotation as viewed from the drive-shaft end of the motor.

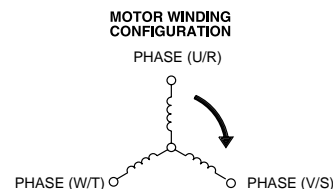

BRAKE OPTIONS TECHNICAL DATA

PMA SERIES MOTORS

The brake is intended for holding or 'parking' of a stationary motor. It may be used for a limited number of emergency stop conditions, however such use will eventually cause wear, leading to eventual malfunction of the brake.

Contamination of the motor internal compartment by oil or other foreign materials will result in failure of the brake. Check the suitability of motor sealing for the working environment.

A PMA motor with integral brake must never be subjected to uncontrolled axial forces or shocks to the motor shaft.

Motor Family	Brake Type	Static Torque @ 120°C		Nominal Torque @ 3,000rpm, 120°C		Weight		Operating Voltage Volt +/-10%	Power Consumption @ 24V, 20°C Watt	Current @ 24V, 20°C		Current @ 24V, 120°C		Inertia Units x 10 ⁻³		Closing Time (engage) mSec	Opening Time (release) mSec
		lb.-in. +/-30%	Nm +/-30%	lb.-in. +/-30%	Nm +/-30%	lbs.	Kg			Amp	Amp	lb.-in.-sec ²	kgm ²				
PMA1 PMA2	04E04	10.6	1.2	5.3	0.6	0.4	0.2	24	8	0.33	0.24	0.11	0.012	25	25		
PMA4	07H22	88.5	10	44.3	5	1.3	0.6	25	16	0.66	0.48	0.97	0.11	20	30		
PMA5	09H22	159.3	16	88.5	10	3.3	1.5	24	13.5	0.56	0.41	3.19	0.36	25	50\		
PMA6	11H00	354.0	40	194.7	22	4.8	2.2	24	24	1	0.73	8.41	0.95	25	75		

Brake data available for R Series and S Series motors. Consult factory or website for details.

CONNECTION INFORMATION BRUSHLESS SERVO MOTORS

POWER CONNECTOR

PMA Series, S Series

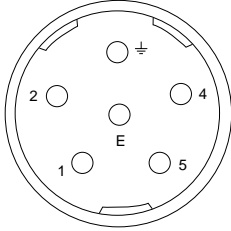

Connector Pin	PMA Series	S Series
1	Phase U	Phase U
2	Phase W	Phase W
gnd	Earth Case	Earth Case
4	Optional Brake -	Optional Brake -
5	Phase V	Phase V
E	Optional Brake +	Optional Brake +

SUGGESTED MATING CONNECTOR

CONNECTOR
LPLA 06D FRRN 213 00 A5
PACIFIC SCIENTIFIC
769-004916-00

FEEDBACK CONNECTOR 12-PIN

PMA Series, S Series with Resolver PMA Series with SinCos Encoder

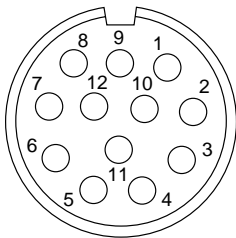

Connector Pin	PMA Series		S Series
	Standard Resolver	SinCos Encoder	Standard Resolver
1	S1	not used	S1
2	S3	not used	S3
3	S4	Sin +	S4
4	S2	Sin REF	S2
5	R1 Excit	Cos +	R1 Excit
6	R2 Excit Rtn	Cos REF	R2 Excit Rtn
7	PTC	RS 485 data -	PTC
8	PTC rtn	RS 485 data +	PTC rtn
9	not used	gnd	not used
10	not used	+ 8V	not used
11	not used	PTC rtn	not used
12	not used	PTC	not used

SUGGESTED MATING CONNECTOR

CONNECTOR
SPNA 12T FRON 169 00 D9
PACIFIC SCIENTIFIC
769-004915-00

FEEDBACK CONNECTOR 17-PIN

PMA Series with Commutating Encoder

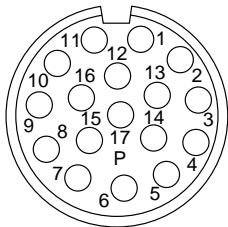

Connector Pin	Commutating Encoder
1	5V +
2	PTC
3	0V supply
4	Hall Sensor W
5	Hall Sensor \bar{W}
6	Hall Sensor U
7	Hall Sensor \bar{U}
8	Hall Sensor V
9	Hall Sensor \bar{V}
10	A
11	\bar{A}
12	B
13	\bar{B}
14	Z
15	\bar{Z}
16	not used
17	PTC rtn

SUGGESTED MATING CONNECTOR

CONNECTOR
SPNA 17H FRON 169 00 E3
PACIFIC SCIENTIFIC
769-004917-00

Contact Pacific Scientific for connection details on S Series motors with alternate feedback devices. MS-type connector options also available.

CONNECTOR DESCRIPTIONS. . .PMB Series Motors

Described here are pinouts of standard Pacific Scientific PMB motors. The pinout of the motor-power connector does not vary among motors with varying feedback configurations.

The pinout of feedback connectors varies with the devices employed and with primary-only or primary-and-secondary configurations.

POWER CONNECTOR

PMB Series

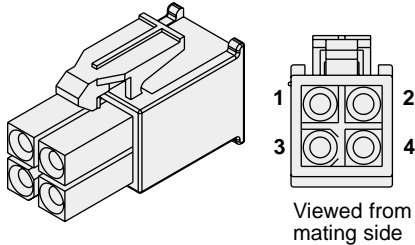

STANDARD PINOUTS– All Series

Connector Pin	PMB Series
1	Phase U
2	Phase V
3	Phase W
4	Ground (Frame)

Shield connected to motor ground point (frame) internal to motor

SUGGESTED MATING CONNECTOR

CONNECTOR PART NUMBER	MATING CONNECTOR PART NUMBER (not supplied)
AMP 172167-1	AMP 172159

FEEDBACK CONNECTOR 15-PIN

PMB Series

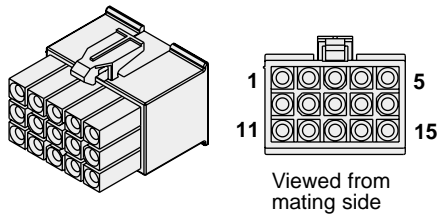

STANDARD PINOUTS– All Series

Connector Pin	PMB Series		
	Function Hall Sensor	Resolver	Encoder
1	N/C	S2 (+Sine)	Channel A
2	N/C	S4 (-Sine)	Channel A
3	N/C	S1 (+Cosine)	Channel B
4	N/C	S3 (-Cosine)	Channel B
5	N/C	R1 (+ Ref)	Index
6	N/C	R2 (- Ref)	Index
7	Supply return	N/C	Supply Return ^①
8	+4 to 24V dc	N/C	+5V dc ^③
9	Shield ^②	Shield ^②	Shield ^②
10	N/C	N/C	N/C
11	Thermistor ^②	Thermistor ^②	Thermistor ^②
12	Thermistor ^②	Thermistor ^②	Thermistor ^②
13	Hall 1	N/C	U (Hall 1)
14	Hall 2	N/C	V (Hall 2)
15	Hall 3	N/C	W (Hall 3)

① Encoder supply power is used to power Hall Sensors.

② Thermistor is optional. Pins are not connected without this option

③ Shields are hot connected at motor end.

SUGGESTED MATING CONNECTOR

CONNECTOR PART NUMBER	MATING CONNECTOR PART NUMBER (not supplied)
AMP 12171-1	AMP 172163

CONNECTOR DESCRIPTIONS. . .S20, S30, R20, R30, R40, R60, R80 Series Motors

Described here are pinouts of standard Pacific Scientific R20, R30, R40, R60 and R80 motors. The pinout of the motor-power connector does not vary among motors with varying feedback configurations.

The pinout of feedback connectors varies with the devices employed and with primary-only or primary-and-secondary configurations.

PRIMARY & SECONDARY FEEDBACK CONNECTOR

All Series
Except R20, S20, S30

MS3102E20-29P

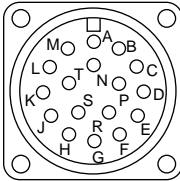

R20 Series, S20, S30
Only

MS3101A20-29P

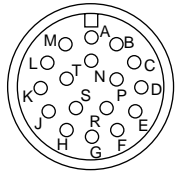

STANDARD PINOUTS—All Series

Connector Pin	Primary Feedback			Secondary Feedback
	Tachsyn	Resolver	Hall Sensors	Encoder
A	Excitation	S4	+Vdc	
B	Excitation RTN	S3	Vdc RTN	
C	Phase 1	S2	Sensor 1	
D	Phase 2	S1	Sensor 2	
E	Phase 3	R1	Sensor 3	
F	Thermistor	Thermistor	Thermistor	
G				Encoder A
H				Encoder \bar{A}
J				Encoder B
K				Encoder \bar{B}
L				Encoder Z
M				Encoder \bar{Z}
N				
P		R2 (excitation RTN)		
R	Thermistor	Thermistor	Thermistor	
S				Encoder +Vdc
T				Encoder Vdc RTN

SUGGESTED MATING CONNECTOR AND CLAMP

CONNECTOR	CLAMP
MS3106A20-29S PACIFIC SCIENTIFIC P/N CZ00009	MS3057-12A-1 PACIFIC SCIENTIFIC P/N CE00003

MOTOR AND PRIMARY FEEDBACK CONNECTOR

(Available for R20 motors with primary feedback only)

R20 Series with rear mounted connector option and S20 with single motor-mounted connector

MS3102E20-29P

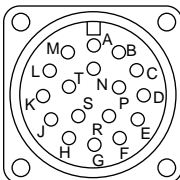

STANDARD PINOUTS

Connector Pin	Motor and Resolver Feedback	Motor and Hall Sensor Feedback
A	Phase R	Phase R
B	Phase S	Phase S
C	Phase T	Phase T
D	N/C	N/C
E	S4	Sensor 1
F	S3	Sensor 2
G	S2	Sensor 3
H	S1	N/C
J	N/C	N/C
K	Thermistor	Thermistor
L	Thermistor	Thermistor
M	N/C	N/C
N	Ground (Frame)	Ground (Frame)
P	N/C	N/C
R	R1 (Excitation)	+V dc
S	R2 (Excitation RTN)	V dc RTN
T	N/C	N/C

SUGGESTED MATING CONNECTOR AND CLAMP

CONNECTOR	CLAMP
MS3106A20-29S PACIFIC SCIENTIFIC P/N CZ00009	MS3057-12A-1 PACIFIC SCIENTIFIC P/N CE00003

CONNECTOR DESCRIPTIONS. . . R20, R30, R40, R60, R80 Series Motors

Described here are pinouts of standard Pacific Scientific R20, R30, R60 and R80 motors. The pinout of the motor-power connector does not vary among motors with varying feedback configurations.

The pinout of feedback connectors varies with the devices employed and with primary-only or primary-and-secondary configurations.

MOTOR CONNECTORS

**S20, S30, R30, R40, R60 Series
MS3102E20-4P**

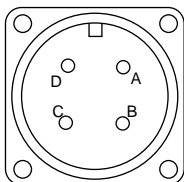

**R80 Series Only
MS3102E24-22P**

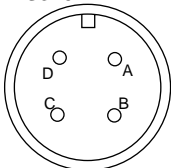

**R20 Series Only
MS3101A20-4P**

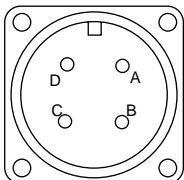

STANDARD PINOUTS— All Series

Connector Pin	Function
A	Phase R
B	Phase S
C	Phase T
D	Ground (Frame)

SUGGESTED MATING CONNECTOR AND CLAMP

SERIES	MATING CONNECTOR	CLAMP
R20, R30 R40, R60	MS3106A20-4S PACIFIC SCIENTIFIC P/N CZ00007	MS3057-12A-1 PACIFIC SCIENTIFIC P/N CE00003
R80	MS3106A24-22S PACIFIC SCIENTIFIC P/N CZ00010	MS3057-16A-1 PACIFIC SCIENTIFIC P/N CE00004

PRIMARY FEEDBACK ONLY — CONNECTORS

**All Series
Except R20**

MS3102E20-7P

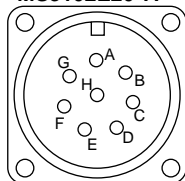

**R20 Series
Only**

MS3101A20-7P

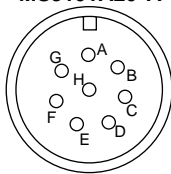

STANDARD PINOUTS—All Series

Connector Pin	Tachsyn	Resolver	Hall Sensors
A	Excitation	S4	+V dc
B	Excitation RTN	S3	V dc RTN
C	Phase 1	S2	Sensor 1
D	Phase 2	S1	Sensor 2
E	Phase 3	R1 (Excitation)	Sensor 3
F	N/C	R2 (Excitation RTN)	N/C
G	Thermistor	Thermistor	Thermistor
H	Thermistor	Thermistor	Thermistor

SUGGESTED MATING CONNECTOR AND CLAMP

CONNECTOR	CLAMP
MS3106A20-7S PACIFIC SCIENTIFIC P/N CZ00008	MS3057-12A-1 PACIFIC SCIENTIFIC P/N CE00003

BRAKE CONNECTOR

MS3102E14S-9P

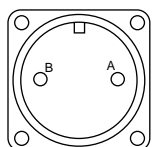

STANDARD PINOUTS

Connector Pin	Function
A	+V dc
B	V dc RTN

SUGGESTED MATING CONNECTOR AND CLAMP

CONNECTOR	CLAMP
MS3106A14S-9S PACIFIC SCIENTIFIC P/N CZ00011	MS3057-6A-1 PACIFIC SCIENTIFIC P/N CE00005

CABLING AND ACCESSORIES

THE ADVANTAGES OF FACTORY CABLING

The most common — and easily preventable — cause of startup problems is cabling. That's why we offer factory tested, fully terminated connecting cables for PacSci brushless servo systems. Factory cabling saves you time as well as troubleshooting.

The PC800 drives are equipped with appropriate connectors for system interconnection. The PMA and S Series motors described in this system selection guide are equipped with Interconnecton connectors. PMB motors offer AMP or MS connectors. One power cable and one feedback cable are necessary for connection between motor and drive.

POWER CABLE — PC800 AND PC3400

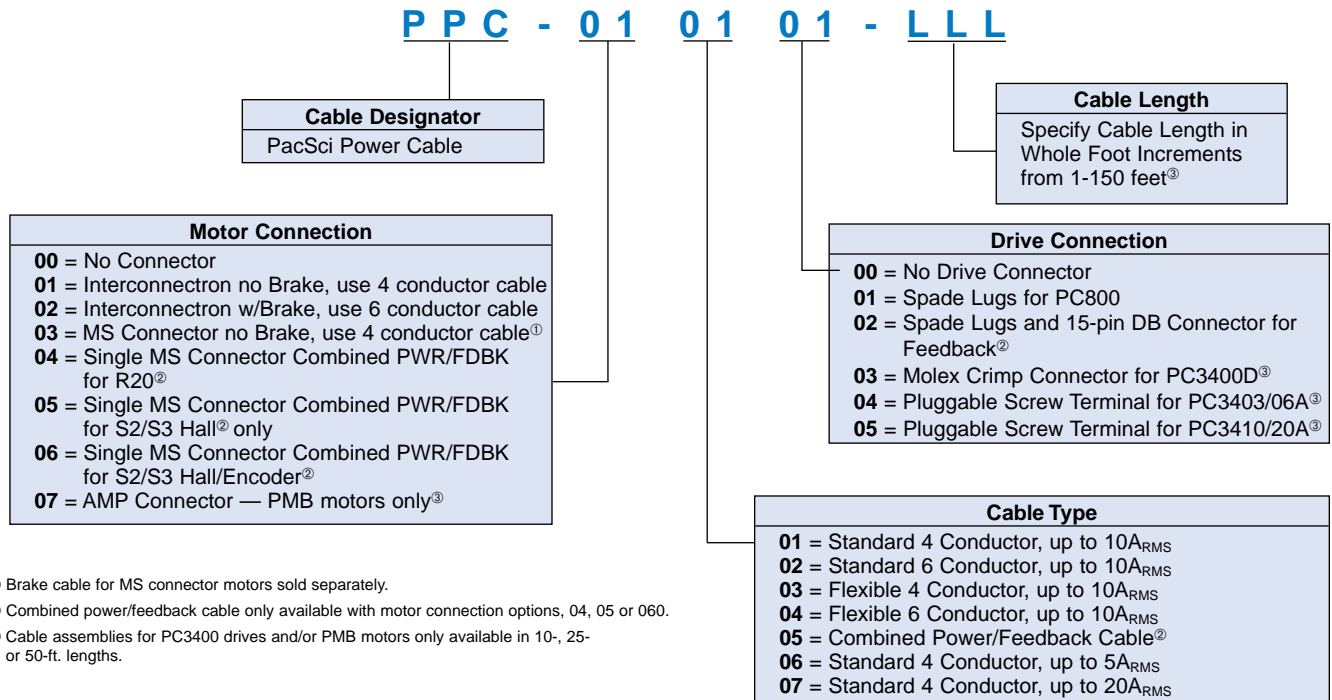

^① Brake cable for MS connector motors sold separately.
^② Combined power/feedback cable only available with motor connection options, 04, 05 or 060.
^③ Cable assemblies for PC3400 drives and/or PMB motors only available in 10-, 25- or 50-ft. lengths.

FEEDBACK CABLE — PC800 AND PC3400

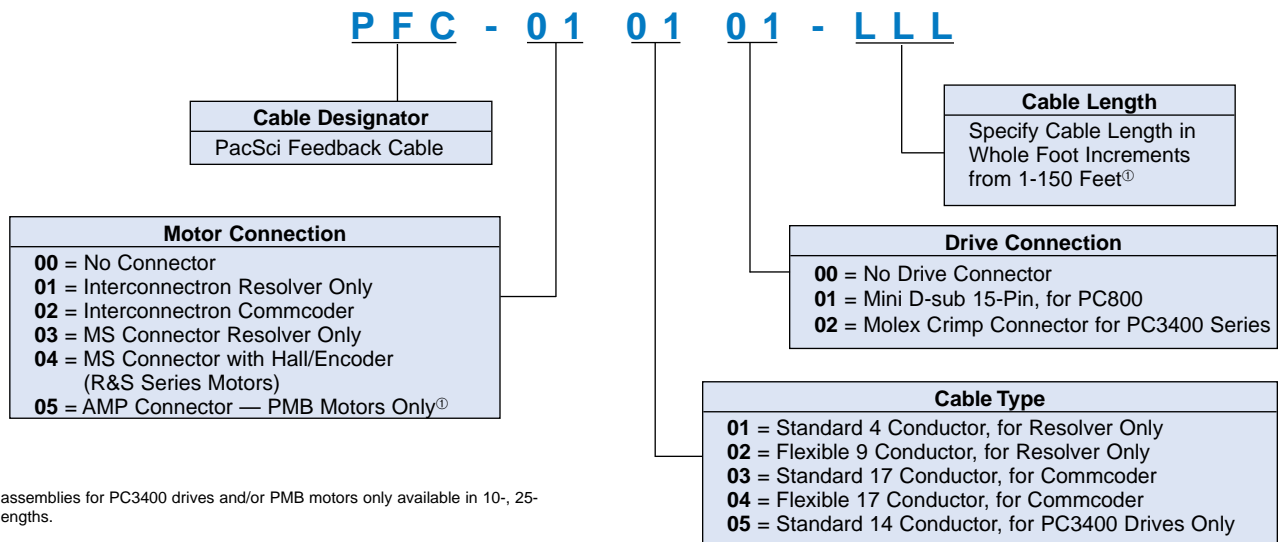

^① Cable assemblies for PC3400 drives and/or PMB motors only available in 10-, 25- or 50-ft. lengths.

CABLING AND ACCESSORIES

THE ADVANTAGES OF FACTORY CABLING

The most common — and easily preventable — cause of startup problems is cabling. That's why we offer factory tested, fully terminated connecting cables for PacSci brushless servo systems. Factory cabling saves you time as well as troubleshooting.

The SC/SCE900 drives are equipped with appropriate connectors for system interconnection. The PMA and S Series motors described in this system selection guide are equipped with Interconnectron connectors. One power cable and one feedback cable are necessary for connection between motor and drive.

POWER CABLE - SC/SCE900

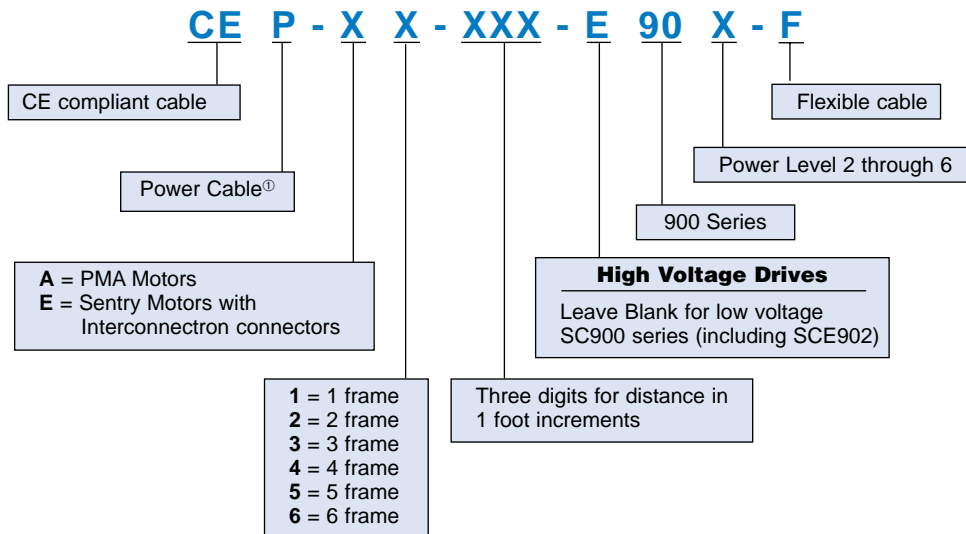

FEEDBACK CABLE - SC/SCE900

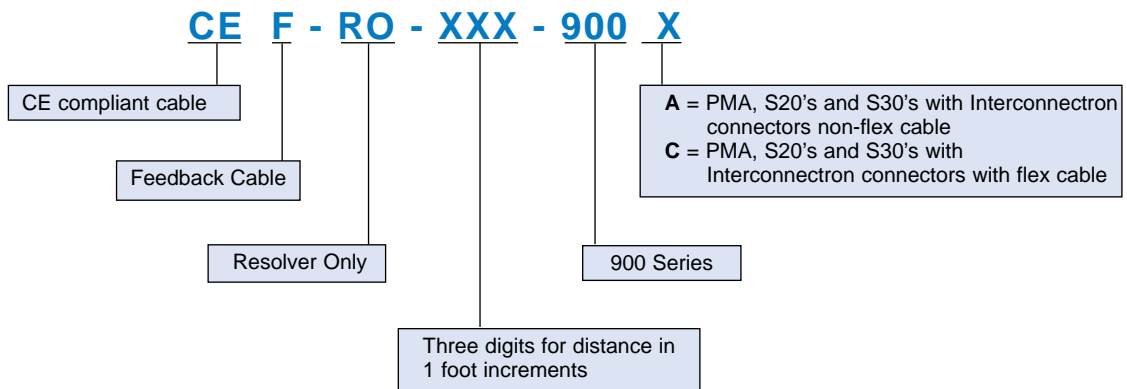

^① Flexible cable is available for High Voltage Drives.

JL91441 01-03-5M

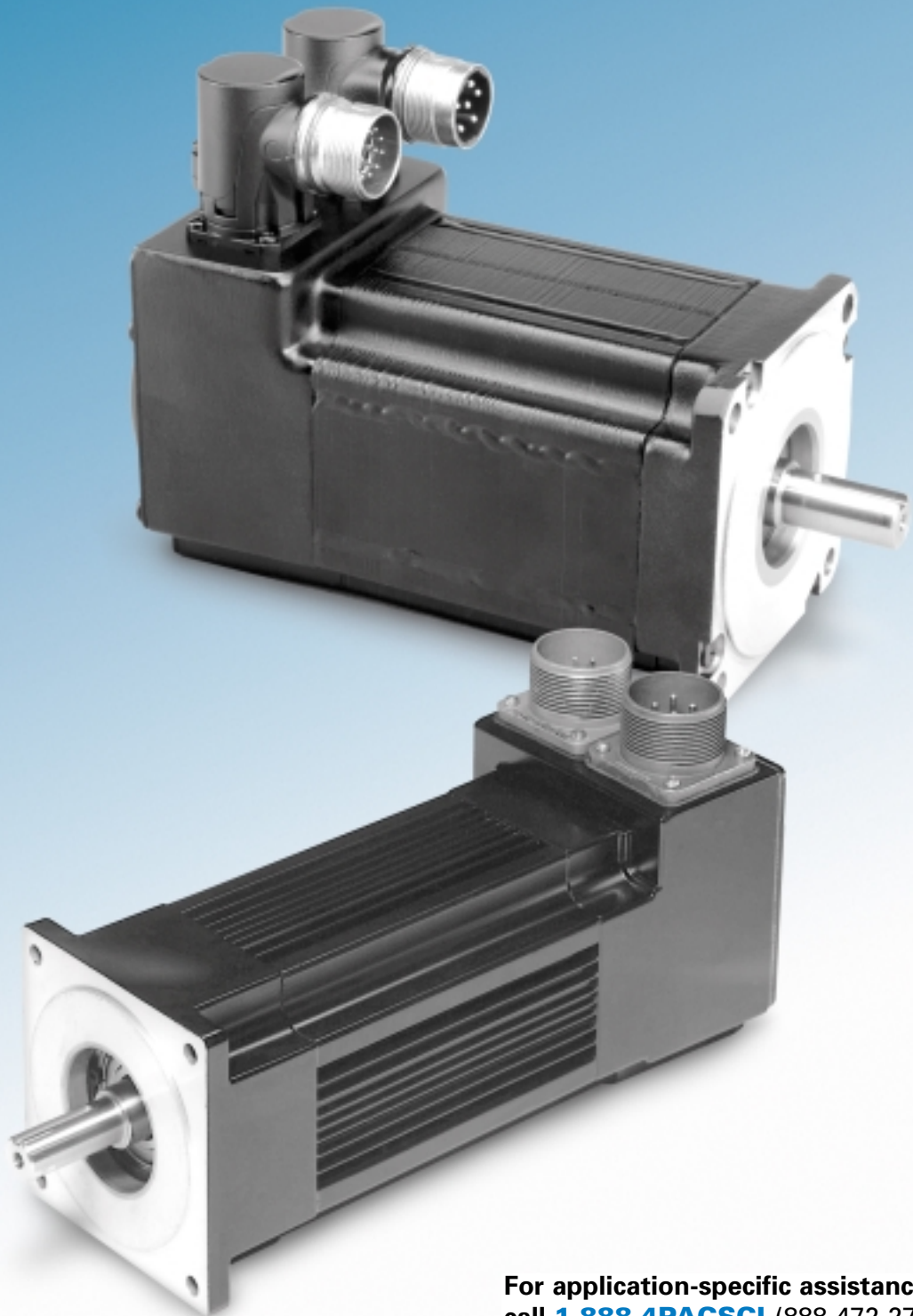

4301 Kishwaukee Street
P.O. Box 106
Rockford, Illinois 61105-0106
TEL: (815) 226-3100
FAX: (815) 226-3080

Locations:
Rockford, IL
Wilmington, MA
Juarez, Mexico

For application-specific assistance,
call **1-888-4PACSCI** (888-472-2724)
www.pacsci.com