

ACCU ELECTRIC MOTORS INC

USA: (888) 932-9183

CANADA: (905) 829-2505

- ✓ Over 100 years cumulative experience
- ✓ 24 hour rush turnaround / technical support service
- ✓ Established in 1993



The leading independent repairer of servo motors and drives in North America.

Visit us on the web:

www.servo-repair.com

www.servorepair.ca

www.ferrocontrol.com

www.sandvikrepair.com

www.accuelectric.com

Scroll down to view your document!

For 24/7 repair services :

USA: 1 (888) 932 - 9183

Canada: 1 (905) 829 -2505

Emergency After hours: 1 (416) 624 0386

Servicing USA and Canada

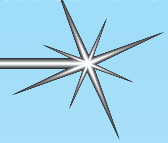

D-Series Servomotors

ORMEC's D-series AC brushless servomotors provide high torque-to-inertia ratios and excellent continuous torque and peak torque performance in a compact design. These industrial-quality servomotors incorporate high-energy, rare earth, neodymium-iron-boron magnets and a highly efficient stator winding design which results in excellent power density.

The D-series servomotors also completely eliminate brush wear maintenance problems, and feature extremely durable construction which includes heavy duty bearings.

Rugged MS connectors provide reliable interconnections to both motor and optical encoder (except for D-Series with IP-67 option selected).

Features

- ❑ Continuous stall torques from 3 to 665 in-lb (0.32 to 75 N-m)
- ❑ High peak torques from 8 to 1,000 in-lb (0.96 to 113 N-m)
- ❑ Output power from 100 to 11,000 watts (0.13 to 15 HP)
- ❑ Compact design with 40% less volume than previous design
- ❑ High maximum speeds from 3,000 to 4,500 RPM
- ❑ Encoder resolutions up to 32,768 counts per revolution
- ❑ Optional absolute encoders feature multi-rev operation
- ❑ Class B or F insulation providing long winding life under rated operating conditions
- ❑ Minimum torque ripple & cogging for smooth low-speed performance
- ❑ Totally Enclosed Non-Ventilated (TENV) standard IP-67 except shaft opening, optional shaft oil seal is available.
- ❑ Fail-safe holding brakes as option

Motor/Drive Combinations

The performance of these servomotors is a direct function of the factory-matched servomotor/drive combination.

ORMEC's ServoWire® drives provide software controlled all-digital performance for consistent operation

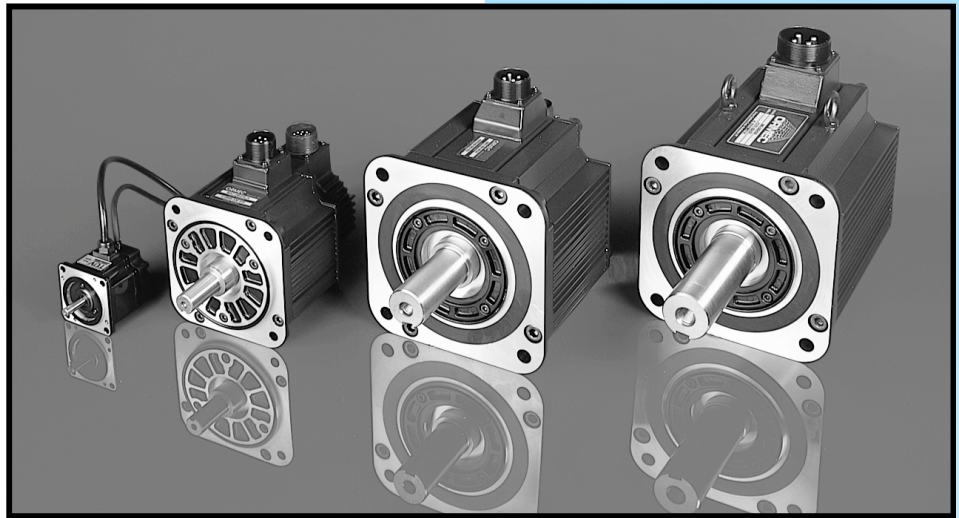

ORMEC's D-series servomotors offer continuous stall torques from 3 to 665 lb-in (0.32 to 75 N-m).

that totally eliminates analog potentiometer adjustments. High bandwidth current mode operation and a quality high resolution encoder provide the response & accuracy for demanding applications. Peak torques up to three times the rated torque are available for a few seconds, allowing the motor/drive to handle high inertial loads & heavy duty cycle requirements.

Each drive's motor parameters are configured in software for high performance and RMS current limiting.

Absolute Encoder Option

Cost-effective absolute encoder support provides axis position over a range of 100,000 revolutions. In continuous uni-directional operation, the position count continually "wraps" through the full range while maintaining absolute position within the cycle. Position is maintained through power cycles by a lithium battery (optional) on the ServoWire® digital drive and a supercapacitor in the servomotor.

Understanding the D-Series Servomotor Model Numbers

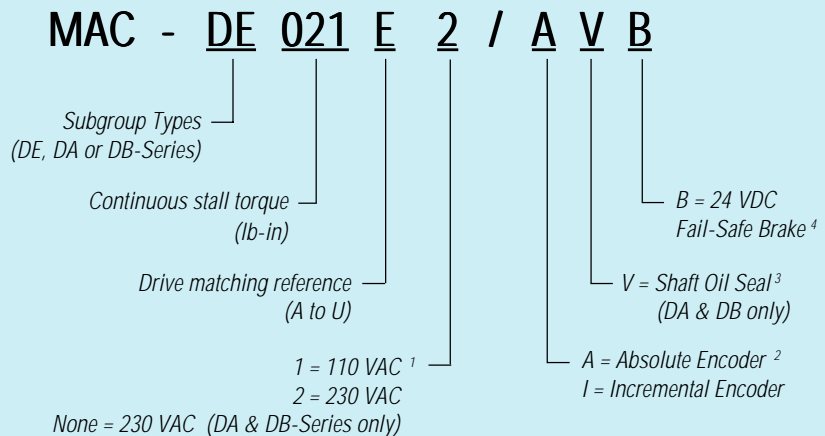

¹ 110 VAC operation is only available on a select number of the DE servomotor subgroup.
² Specify ServoWire drive with absolute encoder support when ordering this motor.
³ Cables are available with an IP-67 rating for all motors in the DA and DB series.
⁴ Specify cables with the brake option when selecting a motor with a Fail-Safe brake.

D-Series Servomotors & Matching Servodrives

Servomotor Model Number	Max. Speed (RPM)	Peak / Stall Torque lb-in (N-m)	Motor Inertia lb-in-sec ² (kg-m ²)	Motor Length in (mm)	Motor Flange in (mm)	Input Power ⁽¹⁾ / ⁽²⁾ watts/amps
MAC-DE003A1	4,500	5.1/2.8 (0.58/0.32)	0.057 x 10 ⁻³ (0.065 x 10 ⁻⁴)	2.24 (57)	2.36 (60)	110 / 1.0
MAC-DE003A2	4,500	8.2/2.8 (0.93/0.32)	0.057 x 10 ⁻³ (0.065 x 10 ⁻⁴)	2.24 (57)	2.36 (60)	110 / 0.5
MAC-DE006B1	4,500	14/5.6 (1.5/0.64)	0.185 x 10 ⁻³ (0.209 x 10 ⁻⁴)	2.44 (62)	3.15 (80)	210 / 1.9
MAC-DE006B2	4,500	11/5.6 (1.3/0.64)	0.185 x 10 ⁻³ (0.209 x 10 ⁻⁴)	2.44 (62)	3.15 (80)	210 / 0.9
MAC-DE008C1	4,500	25/8.4 (2.8/0.95)	0.308 x 10 ⁻³ (0.347 x 10 ⁻⁴)	3.23 (82)	3.15 (80)	320 / 2.4
MAC-DE011C2	4,500	28/11 (3.2/1.3)	0.308 x 10 ⁻³ (0.347 x 10 ⁻⁴)	3.23 (82)	3.15 (80)	440 / 1.9
MAC-DE021D2	4,500	34/21 (3.9/2.4)	1.87 x 10 ⁻³ (2.11 x 10 ⁻⁴)	3.21 (82)	4.72 (120)	825 / 3.6
MAC-DE042E2	4,300	73/42 (8.3/4.8)	3.57 x 10 ⁻³ (4.03 x 10 ⁻⁴)	4.31 (110)	4.72 (120)	1,650 / 7.2
MAC-DA030F	4,500	68/28 (7.7/3.2)	1.54 x 10 ⁻³ (1.74 x 10 ⁻⁴)	5.87 (149)	3.15 (80)	1,100 / 4.8
MAC-DA055G	4,500	101/56 (11/6.3)	2.82 x 10 ⁻³ (3.19 x 10 ⁻⁴)	7.80 (198)	3.15 (80)	2,100 / 9.1
MAC-DA090H	4,500	217/87 (24/9.8)	6.20 x 10 ⁻³ (7.01 x 10 ⁻⁴)	7.83 (199)	5.12 (130)	3,300 / 14
MAC-DA110J	4,500	207/112 (23/13)	8.50 x 10 ⁻³ (9.60 x 10 ⁻⁴)	9.29 (236)	5.12 (130)	4,290 / 19
MAC-DA140K	4,500	321/140 (36/16)	10.9 x 10 ⁻³ (12.3 x 10 ⁻⁴)	10.87 (176)	5.12 (130)	5,390 / 23
MAC-DB025L	3,000	44/25 (4.9/2.8)	6.41 x 10 ⁻³ (7.24 x 10 ⁻⁴)	5.39 (137)	5.12 (130)	485 / 2.1
MAC-DB055M	3,000	88/53 (10/6.0)	12.3 x 10 ⁻³ (13.9 x 10 ⁻⁴)	6.30 (160)	5.12 (130)	940 / 4.1
MAC-DB080N	3,000	152/74 (17/8.4)	18.2 x 10 ⁻³ (20.6 x 10 ⁻⁴)	7.24 (184)	5.12 (130)	1,430 / 6.2
MAC-DB100P	3,000	155/102 (18/12)	28.1 x 10 ⁻³ (31.8 x 10 ⁻⁴)	6.50 (165)	7.09 (180)	1,980 / 8.6
MAC-DB200Q	3,000	312/196 (35/22)	40.7 x 10 ⁻³ (46.0 x 10 ⁻⁴)	7.83 (199)	5.12 (130)	3,190 / 14
MAC-DB300R	3,000	479/300 (54/34)	59.8 x 10 ⁻³ (67.6 x 10 ⁻⁴)	8.86 (225)	7.09 (180)	4,840 / 21
MAC-DB330S	3,000	728/345 (82/39)	78.8 x 10 ⁻³ (89.0 x 10 ⁻⁴)	10.20 (259)	7.09 (180)	6,050 / 26
MAC-DB465T	3,000	839/450 (95/51)	111.0 x 10 ⁻³ (125.4 x 10 ⁻⁴)	13.11 (333)	7.09 (180)	8,250 / 36
MAC-DB700U	2,000	1,128/665 (127/75)	249.0 x 10 ⁻³ (281.4 x 10 ⁻⁴)	13.27 (337)	8.66 (220)	12,100 / 53

¹ Power listed is the required incoming line power in watts when the motor is operating at rated output. To determine total incoming power requirements, add up the listed values for each servomotor/drive combination in the system.

² Current listed in amps is the recommended slow-blow fuse capacity for each leg of the three phase power. To select fuses for the system, add the recommended fuse capacities for each servomotor/drive combination in the system.

D-Series Compatibility Chart

Servomotor Model Number	Single Phase Drives (No Regen)			Three Phase Drives (External Regen)				
	SAC-SW203 SMS-2-203 G03	SAC-SW205 SMS-2-205 G05	SAC-SW210 SMS-2-210 G10	SAC-SW217 SMS-2-217 G17	SAC-SW220 SMS-2-220 G20	SAC-SW225 SMS-2-225 G25	SAC-SW235 SMS-2-235 G35	SAC-SW260 SMS-2-260 G60
MAC-DE003A1	⊗	✓	✓					
MAC-DE003A2	⊗	✓	✓					
MAC-DE006B1		⊗	✓	✓				
MAC-DE006B2	⊗	✓	✓					
MAC-DE008C1			⊗	✓				
MAC-DE011C2		⊗	✓	✓				
MAC-DE021D2		⊗	✓					
MAC-DE042E2			⊗	✓	✓			
MAC-DA030F			⊗	✓	✓			
MAC-DA055G			⊗		✓			
MAC-DA090H						⊗	✓	
MAC-DA110J						⊗	✓	✓
MAC-DA140K							⊗	✓
MAC-DB025L		⊗	✓					
MAC-DB055M			⊗	✓	✓			
MAC-DB080N				⊗	✓			
MAC-DB100P					⊗	✓		
MAC-DB200Q					⊗	✓	✓	
MAC-DB300R							⊗	✓
MAC-DB330S								⊗
MAC-DB465T								⊗
MAC-DB700U								⊗

⊗ Recommended drive model ✓ Compatible drive model



D-Series AC Brushless Servomotors

-- Absolute Encoder Model Specifications
(Inertia specifications for Brake Models on page 11.)

Performance Specifications (1)		Units	DE003A1		DE003A2		DE006B1	
Maximum Speed	RPM		4,500		4,500		4,500	
Continuous Stall Torque	lb-in		2.8		2.8		5.6	
	N-m		0.32		0.32		0.64	
Rated Speed	RPM		3,000		3,000		3,000	
Rated Torque	lb-in		2.8		2.8		5.6	
	N-m		0.32		0.32		0.64	
Rated Power	HP		0.13		0.13		0.25	
	watts		100		100		190	
Peak Torque ⁽²⁾	lb-in		5.1		8.2		14	
	N-m		0.58		0.93		1.5	
Continuous Stall Torque/Inertia	radians/sec ²		49,123	35,443	49,123	35,443	30,270	27,053

Mechanical Specifications								
Moment of Inertia	lb-in-sec ² x 10 ⁻³		0.057	0.079	0.057	0.079	0.185	0.207
	kg-m ² x 10 ⁻⁴		0.065	0.089	0.065	0.089	0.209	0.234
Friction Torque, Static	lb-in		0.048		0.048		0.11	
	N-m		0.0054		0.0054		0.012	
Servomotor Weight	lbs		1.5	2.0	1.5	2.0	3.1	3.5
	kg		0.7	0.9	0.7	0.9	1.4	1.6
Maximum Radial Shaft Load (centered 0.2" from end of shaft)	lbs		17		17		55	
	N		78		78		245	
Maximum Axial Shaft Load	lbs		11		11		15	
	N		49		49		68	

Electrical Specifications								
Torque Sensitivity	lb-in/Amp _{Rms/Ø}		1.4		3.5		2.3	
	N-m/Amp _{Rms/Ø}		0.16		0.39		0.26	
Servodrive Model Number	SAC-		SAC-SW203/E	SAC-SW203/EA	SAC-SW203/E	SAC-SW203/EA	SAC-SW205/E	SAC-SW205/EA
			SMS-203/E	SMS-203/EA	SMS-203/E	SMS-203/EA	SMS-205/E	SMS-205/EA
			G03-AY		G03-AY		G05-AY	
Servodrive Input Power	volts AC		115		230		115	
Continuous Motor Current	Amps _{Rms/Ø}		2.2		0.89		2.7	
Peak Motor Current	Amps _{Rms/Ø}		7.1		2.8		8.4	

Motor Thermal Specifications			
Ambient Temperature	degrees C	40	
Insulation Class		B	

Encoder Specifications			
Encoder Resolution	counts/revolution	8192	4096

(1) Ratings are obtained with servomotor ambient temperature of 40C, and armature winding temperature of 100C. (2) Motor's peak torque is limited by the peak current of the servodrive. The next larger drive may be used to increase the amount of peak torque available. Consult an ORMEC Applications Engineer for details.

Torque vs. Speed Characteristics

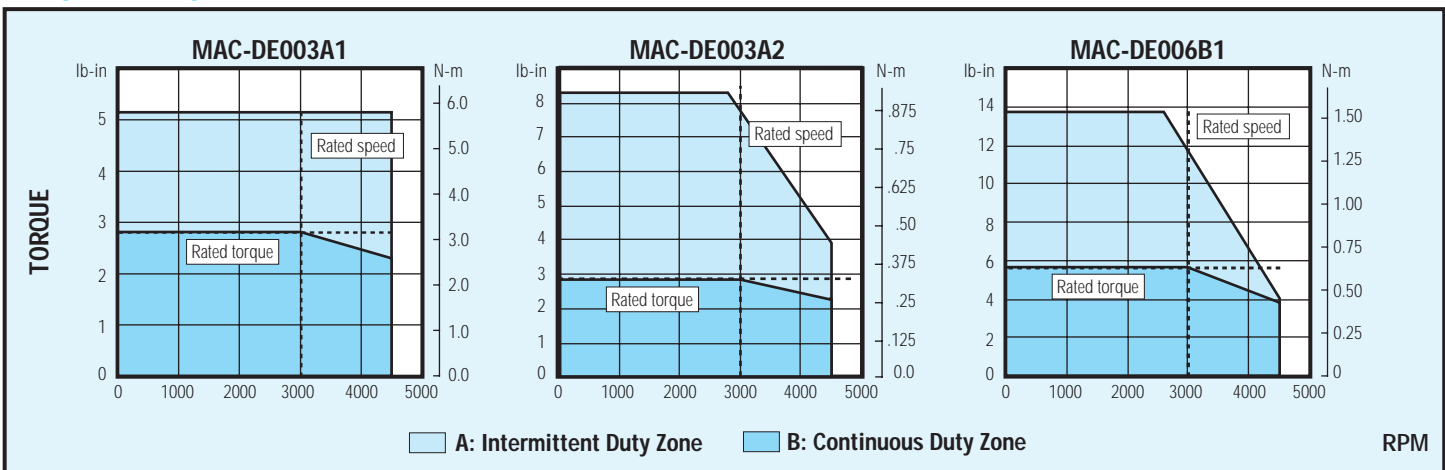



D-Series AC Brushless Servomotors

-- Absolute Encoder Model Specifications
(Inertia specifications for Brake Models on page 11.)

Performance Specifications (1)	Units	DE006B2		DE008C1		DE011C2	
Maximum Speed	RPM	4,500		4,500		4,500	
Continuous Stall Torque	lb-in	5.6		8.4		11	
	N-m	0.64		0.95		1.3	
Rated Speed	RPM	3,000		3,000		3,000	
Rated Torque	lb-in	5.6		8.4		11	
	N-m	0.64		0.95		1.3	
Rated Power	HP	0.25		0.39		0.54	
	watts	190		290		400	
Peak Torque ⁽²⁾	lb-in	11		25		28	
	N-m	1.3		2.8		3.2	
Continuous Stall Torque/Inertia	radians/sec ²	30,270	27,053	27,273	25,532	35,714	33,435

Mechanical Specifications							
Moment of Inertia	lb-in-sec ² x 10 ⁻³	0.185	0.207	0.308	0.329	0.308	0.329
	kg-m ² x 10 ⁻⁴	0.209	0.234	0.347	0.372	0.347	0.372
Friction Torque, Static	lb-in	0.11		0.20		0.20	
	N-m	0.012		0.022		0.022	
Servomotor Weight	lbs	3.1	3.5	4.6	5.1	4.6	5.1
	kg	1.4	1.6	2.1	2.3	2.1	2.3
Maximum Radial Shaft Load (centered 0.2" from end of shaft)	lbs	55		55		55	
	N	245		245		245	
Maximum Axial Shaft Load	lbs	15		15		15	
	N	68		68		68	

Electrical Specifications							
Torque Sensitivity	lb-in/Amp _{Rms/Ø}	3.1		2.2		4.7	
	N-m/Amp _{Rms/Ø}	0.35		0.25		0.54	
Servodrive Model Number		SAC-SW203/E	SAC-SW203/EA	SAC-SW210/E	SAC-SW210/EA	SAC-SW205E	SAC-SW205/EA
		SMS-203/E	SMS-203/EA	SMS-210/E	SMS-210/EA	SMS-205/E	SMS-205/EA
		G03-AY		G10-AY		G05-AY	
Servodrive Input Power	volts AC	230		115		230	
Continuous Motor Current	Amps _{Rms/Ø}	2.0		4.3		2.6	
Peak Motor Current	Amps _{Rms/Ø}	6.0		14		8.0	

Motor Thermal Specifications							
Ambient Temperature	degrees C	40		40		40	
Insulation Class		B		B		B	

Encoder Specifications							
Encoder Resolution	counts/revolution	8192	4096	8192	4096	8192	4096

(1) Ratings are obtained with servomotor ambient temperature of 40C, and armature winding temperature of 100C. (2) Motor's peak torque is limited by the peak current of the ServoWire™ drive. The next larger drive may be used to increase the amount of peak torque available. Consult an ORMEC Applications Engineer for details.

Torque vs. Speed Characteristics

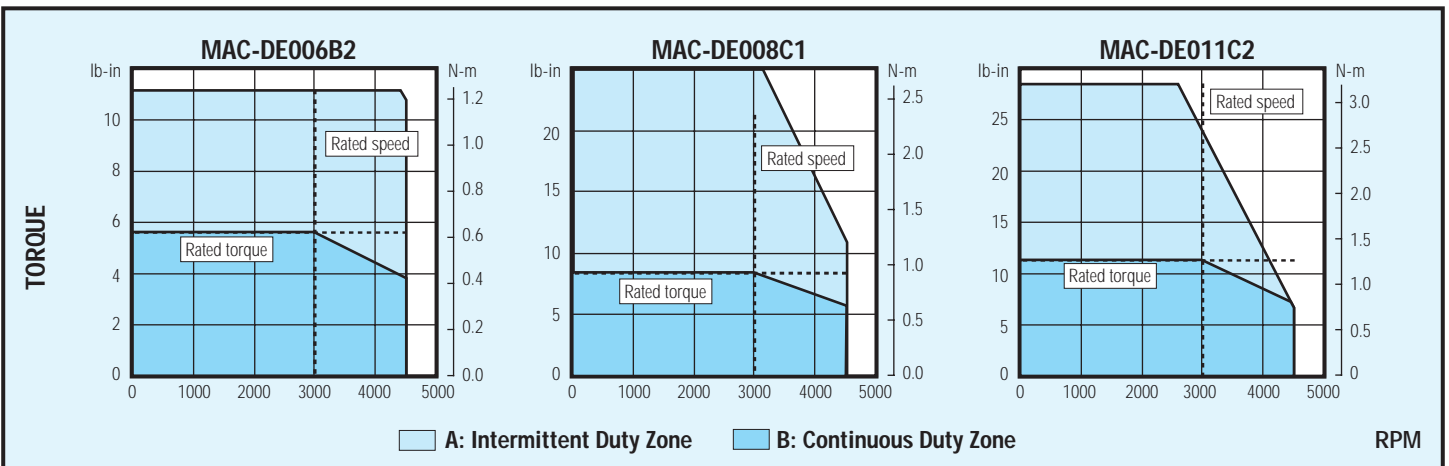



D-Series AC Brushless Servomotors

☆ -- Absolute Encoder Model Specifications
(Inertia specifications for Brake Models on page 11.)

Performance Specifications (1)	Units	DE021D2		DE042E2		DA030F	
Maximum Speed	RPM	4,500		4,300		4,500	
Continuous Stall Torque	lb-in	21		42		28	
	N-m	2.4		4.8		3.2	
Rated Speed	RPM	3,000		3,000		3,000	
Rated Torque	lb-in	21		42		28	
	N-m	2.4		4.8		3.2	
Rated Power	HP	1.0		2.0		1.3	
	watts	750		1500		1000	
Peak Torque ⁽²⁾	lb-in	34		73		68	
	N-m	3.9		8.3		7.7	
Continuous Stall Torque/Inertia	radians/sec ²	11,230	11,111	11,765	11,699	18,182	16,970

Mechanical Specifications							
Moment of Inertia	lb-in-sec ² x 10 ⁻³	1.87	1.89	3.57	3.59	1.54	1.65
	kg-m ² x 10 ⁻⁴	2.11	2.14	4.03	4.06	1.74	1.86
Friction Torque, Static	lb-in	0.32		0.53		0.43	
	N-m	0.036		0.060		0.049	
Servomotor Weight	lbs	10	11	15	16	10	11.0
	kg	4.6	4.8	6.6	7.1	4.6	5.0
Maximum Radial Shaft Load (centered 0.2" from end of shaft)	lbs	88		110		154 ⁽³⁾	
	N	392		490		686 ⁽³⁾	
Maximum Axial Shaft Load	lbs	33		33		44	
	N	147		147		196	

Electrical Specifications							
Torque Sensitivity	lb-in/Amp _{Rms/Ø}	5.7		6.1		5.7	
	N-m/Amp _{Rms/Ø}	0.64		0.69		0.64	
Servodrive Model Number		SAC-SW205/E	SAC-SW205/EA	SAC-SW210/E	SAC-SW210/EA	SAC-SW210/E	SAC-SW210/EA
		SMS-205/E	SMS-205/EA	SMS-210/E	SMS-210/EA	SMS-210/E	SMS-210/EA
		G05-AY		G10-AY		G10-AY	
Servodrive Input Power	volts AC	230		230		230	
Continuous Motor Current	Amps _{Rms/Ø}	4.1		7.5		6.0	
Peak Motor Current	Amps _{Rms/Ø}	13		28		17	

Motor Thermal Specifications							
Ambient Temperature	degrees C	40		40		40	
Insulation Class		B		B		F	

Encoder Specifications							
Encoder Resolution	counts/revolution	8192	4096	8192	4096	16384	32768

(1) Ratings are obtained with servomotor ambient temperature of 40C, and armature winding temperature of 100C. (2) Motor's peak torque is limited by the peak current of the ServoWire™ drive. The next larger drive may be used to increase the amount of peak torque available. Consult an Ormec Applications Engineer for details. (3) Load centered at end of shaft.

Torque vs. Speed Characteristics

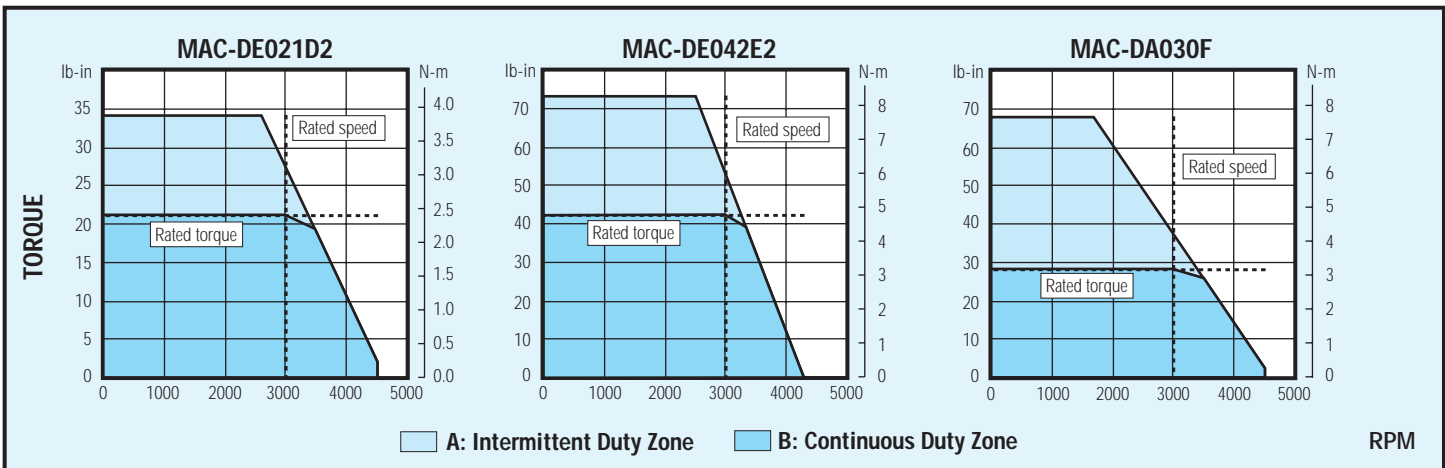



D-Series AC Brushless Servomotors

-- Absolute Encoder Model Specifications
(Inertia specifications for Brake Models on page 11.)

Performance Specifications (1)		Units	DA055G	DA090H	DA110J
Maximum Speed	RPM		4,500	4,500	4,500
Continuous Stall Torque	lb-in		56	87	112
	N-m		6.3	9.8	13
Rated Speed	RPM		3,000	3,000	3,000
Rated Torque	lb-in		56	87	112
	N-m		6.3	9.8	13
Rated Power	HP		2.5	4.0	5.2
	watts		1900	3,000	3,900
Peak Torque ⁽²⁾	lb-in		101	217	207
	N-m		11	24	23
Continuous Stall Torque/Inertia	radians/sec ²		19,858	14,032	13,176

Mechanical Specifications								
Moment of Inertia	lb-in-sec ² x 10 ⁻³		2.82	2.93	6.20	6.31	8.50	8.61
	kg-m ² x 10 ⁻⁴		3.19	3.31	7.01	7.13	9.60	9.73
Friction Torque, Static	lb-in		0.62		0.74		0.95	
	N-m		0.070		0.083		0.11	
Servomotor Weight	lbs		15	16	24	25	31	32
	kg		7.0	7.4	11	12	14	15
Maximum Radial Shaft Load (centered at end of shaft)	lbs		154		221		265	
	N		686		980		1,176	
Maximum Axial Shaft Load	lbs		44		88		88	
	N		196		392		392	

Electrical Specifications							
Torque Sensitivity	lb-in/Amp _{Rms/Ø}		5.0		5.1		4.9
	N-m/Amp _{Rms/Ø}		0.56		0.58		0.55
Servodrive Model Number		SAC-SW217/E	SAC-SW217/EA	SAC-SW225/E	SAC-SW225/EA	SAC-SW225/E	SAC-SW225/EA
		SMS-217/E	SMS-217/EA	SMS-225/E	SMS-225/EA	SMS-225/E	SMS-225/EA
		G17-AY		G25-AY		G25-AY	
Servodrive Input Power	volts AC		230		230		230
Continuous Motor Current	Amps _{Rms/Ø}		12		19		24
Peak Motor Current	Amps _{Rms/Ø}		42		56		77

Motor Thermal Specifications			
Ambient Temperature	degrees C		40
Insulation Class			F

Encoder Resolution			
Encoder Resolution	counts/revolution	16384	32768

(1) Ratings are obtained with servomotor ambient temperature of 40C, and armature winding temperature of 100C. (2) Motor's peak torque is limited by the peak current of the ServoWire™ drive. The next larger drive may be used to increase the amount of peak torque available. Consult an ORMEC Applications Engineer for details.

Torque vs. Speed Characteristics

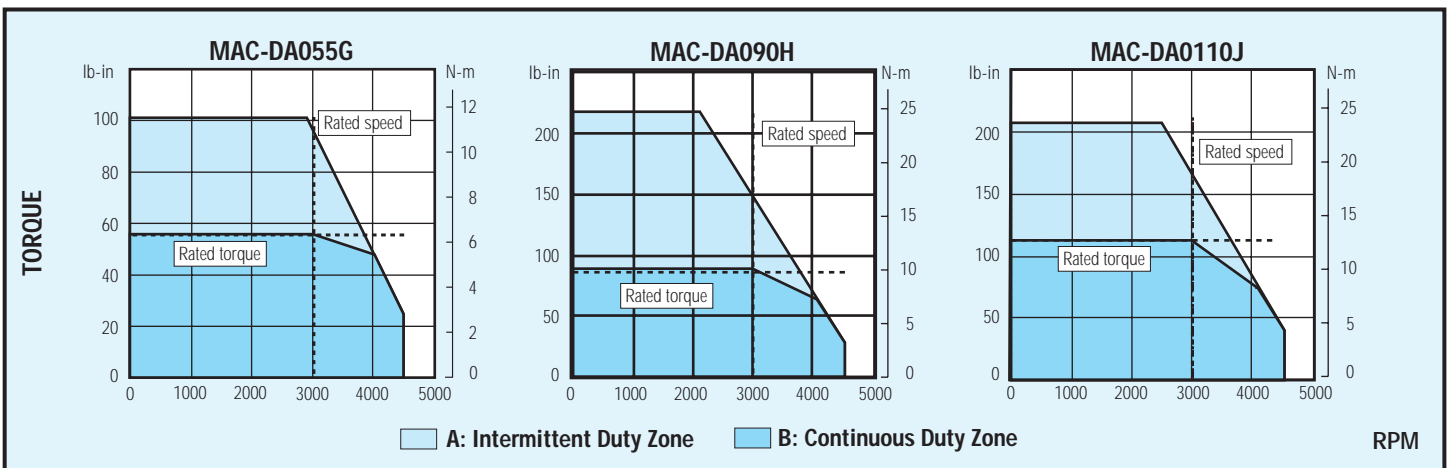



D-Series AC Brushless Servomotors

☆ -- Absolute Encoder Model Specifications
(Inertia specifications for Brake Models on page 11.)

Performance Specifications (1)	Units	DA140K	DB025L	DB055M			
Maximum Speed	RPM	4,500	3,000	3,000			
Continuous Stall Torque	lb-in	140	25	53			
	N-m	16	2.8	6.0			
Rated Speed	RPM	3,000	1,500	1,500			
Rated Torque	lb-in	140	25	48			
	N-m	16	2.8	5.4			
Rated Power	HP	6.6	0.59	1.1			
	watts	4,900	440	850			
Peak Torque ⁽²⁾	lb-in	321	44	88			
	N-m	36	4.9	10			
Continuous Stall Torque/Inertia	radians/sec ²	12,844	12,727	3,900	3,846	4,309	4,274

Mechanical Specifications							
Moment of Inertia	lb-in-sec ² x 10 ⁻³	10.9	11.0	6.41	6.50	12.3	12.4
	kg-m ² x 10 ⁻⁴	12.3	12.4	7.24	7.34	13.9	14.0
Friction Torque, Static	lb-in	1.1		0.43		0.65	
	N-m	0.13		0.049		0.074	
Servomotor Weight	lbs	37	39	12	13.0	17	18
	kg	17	18	5.5	5.9	7.6	8.0
Maximum Radial Shaft Load (centered at end of shaft)	lbs	265		110		110	
	N	1,176		490		490	
Maximum Axial Shaft Load	lbs	88		22		22	
	N	392		98		98	

Electrical Specifications							
Torque Sensitivity	lb-in/Amp _{Rms/Ø}	5.4		7.3		7.3	
	N-m/Amp _{Rms/Ø}	0.61		0.82		0.83	
Servodrive Model Number		SAC-SW235/E SMS-235/E G35-AY	SAC-SW235/EA SMS-235/EA	SAC-SW205/E SMS-205/E G05-AY	SAC-SW205/EA SMS-205/EA	SAC-SW210/E SMS-210/E G10-AY	SAC-SW210/EA SMS-210/EA
Servodrive Input Power	volts AC	230		230		230	
Continuous Motor Current	Amps _{Rms/Ø}	28		3.8		7.1	
Peak Motor Current	Amps _{Rms/Ø}	84		11		17	

Motor Thermal Specifications				
Ambient Temperature	degrees C	40	40	40
Insulation Class		F	F	F

Encoder Specifications							
Encoder Resolution	counts/revolution	16384	32768	32768	32768	32768	32768

(1) Ratings are obtained with servomotor ambient temperature of 40C, and armature winding temperature of 100C. (2) Motor's peak torque is limited by the peak current of the ServoWire™ drive. The next larger drive may be used to increase the amount of peak torque available. Consult an ORMEC Applications Engineer for details.

Torque vs. Speed Characteristics

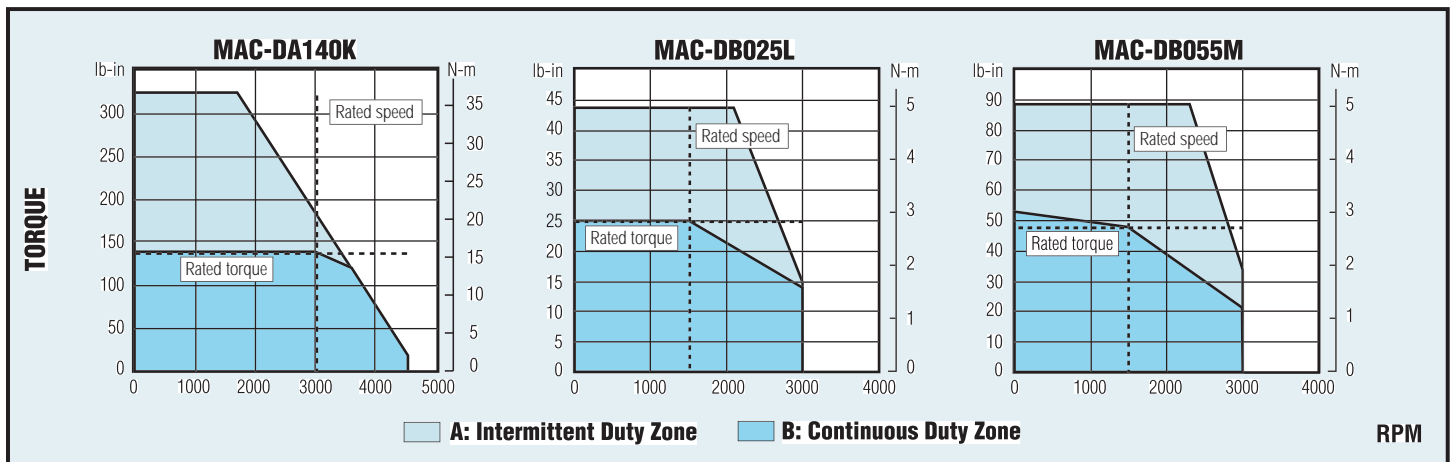



D-Series AC Brushless Servomotors

-- Absolute Encoder Model Specifications
(Inertia specifications for Brake Models on page 11.)

Performance Specifications (1)		Units	DB080N		DB100P		DB200Q	
Maximum Speed	RPM		3,000		3,000		3,000	
Continuous Stall Torque	lb-in		74		102		196	
	N-m		8.4		12		22	
Rated Speed	RPM		1,500		1,500		1,500	
Rated Torque	lb-in		74		102		165	
	N-m		8.4		12		19	
Rated Power	HP		1.7		2.4		3.9	
	watts		1,300		1,800		2,900	
Peak Torque ⁽²⁾	lb-in		152		155		312	
	N-m		17		18		35	
Continuous Stall Torque/Inertia	radians/sec ²		4,066	4,044	3,630	3,617	4,816	4,804

Mechanical Specifications								
Moment of Inertia	lb-in-sec ² x 10 ⁻³		18.2	18.3	28.1	28.2	40.7	40.8
	kg-m ² x 10 ⁻⁴		20.6	20.7	31.8	31.9	46.0	46.1
Friction Torque, Static	lb-in		0.87		1.0		1.4	
	N-m		0.098		0.12		0.16	
Servomotor Weight	lbs		21	22	31	31	40	41
	kg		9.6		14	14	18	19
Maximum Radial Shaft Load (centered at end of shaft)	lbs		154		265		331	
	N		686		1,176		1,470	
Maximum Axial Shaft Load	lbs		77		110		110	
	N		343		490		490	

Electrical Specifications								
Torque Sensitivity	lb-in/Amp _{Rms/Ø}		7.4		6.5		7.3	
	N-m/Amp _{Rms/Ø}		0.84		0.73		0.83	
Servodrive Model Number	SAC-		SW217/E	SW217/EA	SW220/E	SW220/EA	SW225/E	SW225/EA
			SMS-217/E	SMS-217/EA	SMS-220/E	SMS-220/EA	SMS-225/E	SMS-225/EA
			G17-AY		G20-AY		G25-AY	
Servodrive Input Power	volts AC		230		230		230	
Continuous Motor Current	Amps _{Rms/Ø}		11		17		24	
Peak Motor Current	Amps _{Rms/Ø}		28		42		56	

Motor Thermal Specifications			
Ambient Temperature	degrees C	40	
Insulation Class		F	

Encoder Specifications							
Encoder Resolution	counts/revolution	32768	32768	32768	32768	32768	32768

(1) Ratings are obtained with servomotor ambient temperature of 40C, and armature winding temperature of 100C. (2) Motor's peak torque is limited by the peak current of the ServoWire™ drive. The next larger drive may be used to increase the amount of peak torque available. Consult an ORMEC Applications Engineer for details.

Torque vs. Speed Characteristics

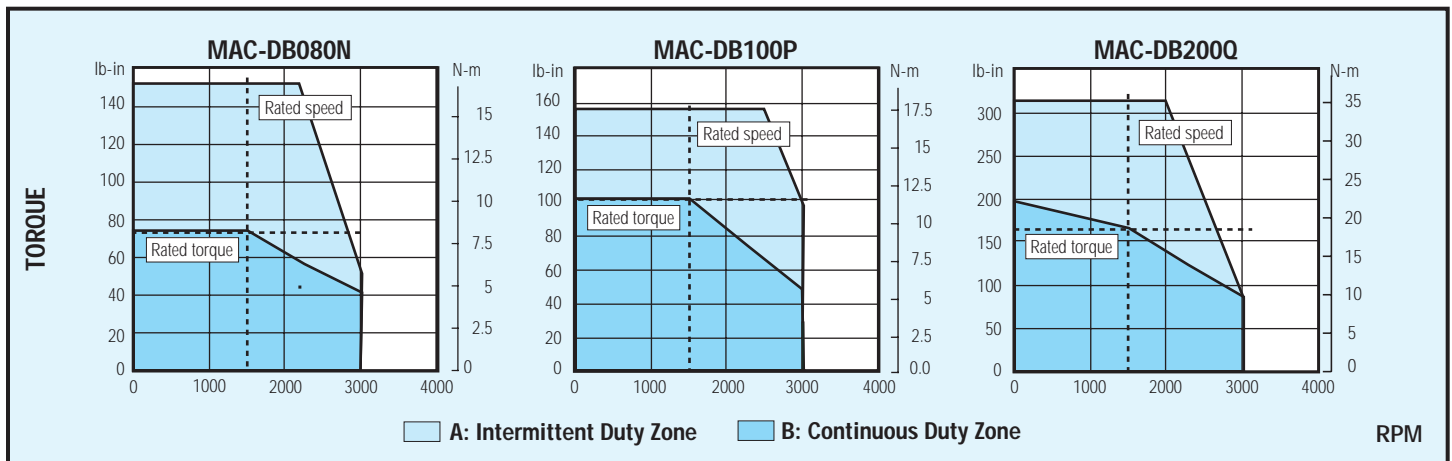



D-Series AC Brushless Servomotors

☆ -- Absolute Encoder Model Specifications
(Inertia specifications for Brake Models on page 11.)



Performance Specifications (1)	Units	DB300R		DB330S	
Maximum Speed	RPM	3,000		3,000	
Continuous Stall Torque	lb-in	300		345	
	N-m	34		39	
Rated Speed	RPM	1,500		1,500	
Rated Torque	lb-in	252		310	
	N-m	28		35	
Rated Power	HP	5.9		7.4	
	watts	4,400		5,500	
Peak Torque ⁽²⁾	lb-in	479		728	
	N-m	54		82	
Continuous Stall Torque/Inertia	radians/sec ²	5,017	5,008	4,378	4,323

Mechanical Specifications					
Moment of Inertia	lb-in-sec ² x 10 ⁻³	59.8	59.9	78.8	79.8
	kg-m ² x 10 ⁻⁴	67.6	67.7	89.0	90.2
Friction Torque, Static	lb-in	2.3		3.0	
	N-m	0.25		0.33	
Servomotor Weight	lbs	51	53	66	65
	kg	23	24	30	30
Maximum Radial Shaft Load (centered at end of shaft)	lbs	331		397	
	N	1,470		1,764	
Maximum Axial Shaft Load	lbs	110		132	
	N	490		588	

Electrical Specifications					
Torque Sensitivity	lb-in/Amp _{Rms/Ø}	8.1		7.8	
	N-m/Amp _{Rms/Ø}	0.91		0.88	
Servodrive Model Number		SAC-SW235/E	SAC-SW235/EA	SAC-SW260/E	SAC-SW260/EA
		SMS-235/E	SMS-235/EA	SMS-260/E	SMS-260/EA
		G35-AY		G60-AY	
Servodrive Input Power	volts AC	230		230	
Continuous Motor Current	Amps _{Rms/Ø}	33		42	
Peak Motor Current	Amps _{Rms/Ø}	84		110	

Motor Thermal Specifications					
Ambient Temperature	degrees C	40		40	
Insulation Class		F		F	

Encoder Specifications					
Encoder Resolution	counts/revolution	32768	32768	32768	32768

(1) Ratings are obtained with servomotor ambient temperature of 40C, and armature winding temperature of 100C. (2) Motor's peak torque is limited by the peak current of the ServoWire™ drive. The next larger drive may be used to increase the amount of peak torque available. Consult an ORMEC Applications Engineer for details.

Torque vs. Speed Characteristics

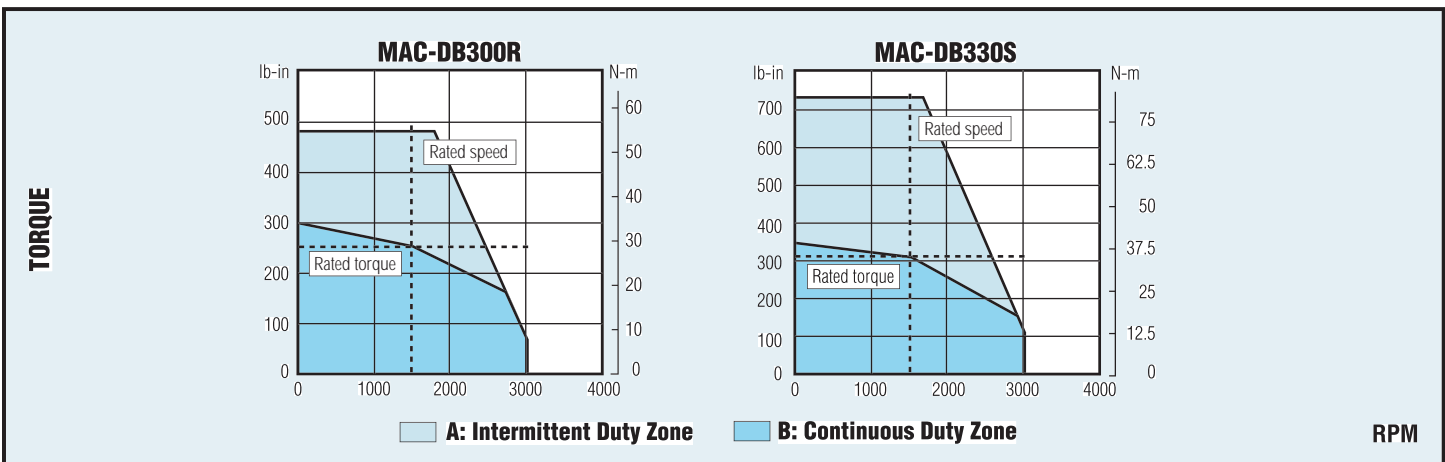



D-Series AC Brushless Servomotors

✦ -- Absolute Encoder Model Specifications
(Inertia specifications for Brake Models on page 11.)



Performance Specifications (1)	Units	DB465T		DB700U	
Maximum Speed	RPM	3,000		2,000	
Continuous Stall Torque	lb-in	450		665	
	N-m	51		75	
Rated Speed	RPM	1,500		1,500	
Rated Torque	lb-in	425		620	
	N-m	48		70	
Rated Power	HP	10		15	
	watts	7,500		11,000	
Peak Torque ⁽²⁾	lb-in	839		1,000	
	N-m	95		113	
Continuous Stall Torque/Inertia	radians/sec ²	4,054	4,054	2,671	2,671

Mechanical Specifications					
Moment of Inertia	lb-in-sec ² x 10 ⁻³	111.0	111.0	249.0	249.0
	kg-m ² x 10 ⁻⁴	125.4	125.4	281.4	281.4
Friction Torque, Static	lb-in	4.2		7.2	
	N-m	0.47		0.81	
Servomotor Weight	lbs	88	88	127	127
	kg	40	40	58	58
Maximum Radial Shaft Load (centered at end of shaft)	lbs	397		397	
	N	1,764		1,764	
Maximum Axial Shaft Load	lbs	132		132	
	N	588		588	

Electrical Specifications					
Torque Sensitivity	lb-in/Amp _{Rms/Ø}	8.2		11	
	N-m/Amp _{Rms/Ø}	0.93		1.2	
Servodrive Model Number		SAC-SW260/E	SAC-SW260/EA	SAC-SW260/E	SAC-SW260/EA
		SMS-260/E	SMS-260/EA	SMS-260/E	SMS-260/EA
		G60-AY		G60-AY	
Servodrive Input Power	volts AC	230		230	
Continuous Motor Current	Amps _{Rms/Ø}	55		59	
Peak Motor Current	Amps _{Rms/Ø}	130		140	

Motor Thermal Specifications					
Ambient Temperature	degrees C	40		40	
Insulation Class		F		F	

Encoder Specifications					
Encoder Resolution	counts/revolution	32768	32768	32768	32768

(1) Ratings are obtained with servomotor ambient temperature of 40C, and armature winding temperature of 100C. (2) Motor's peak torque is limited by the peak current of the ServoWire™ drive. The next larger drive may be used to increase the amount of peak torque available. Consult an ORMEC Applications Engineer for details.

Torque vs. Speed Characteristics

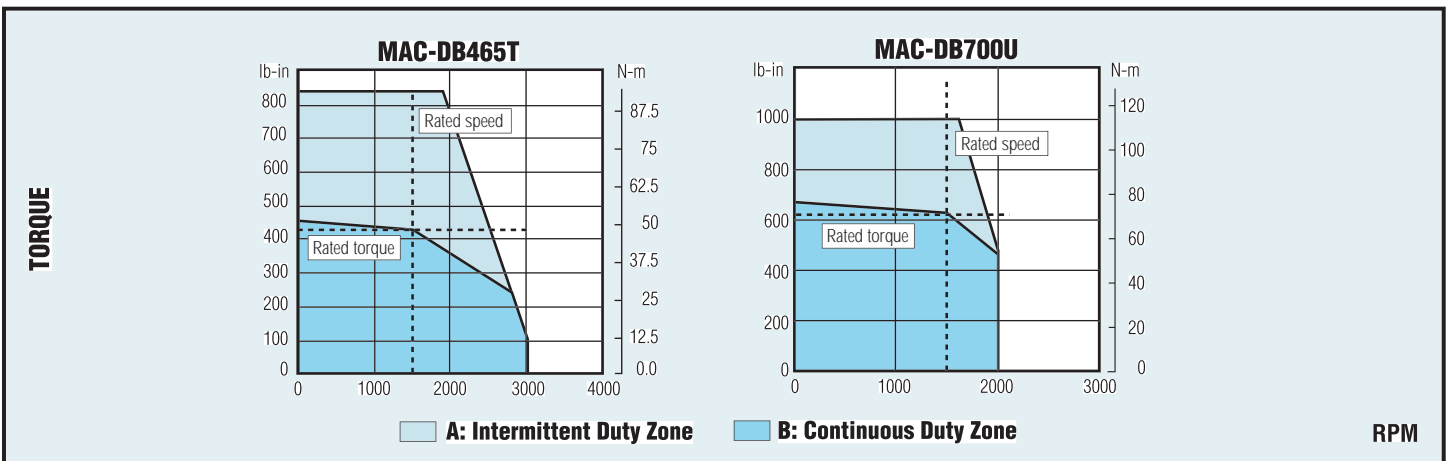

Specifications for D-Series Servomotors with Fail-Safe Brakes

Servomotor Model Number	Brake Holding Torque ⁽¹⁾ (lb-in / N-m)	MODEL with BRAKE				MODEL with BRAKE & ABSOLUTE ENCODER			
		Continuous Stall Torque to Inertia Ratio (radians/sec ²)	Moment of Inertia (lb-in-sec ² / kg-m ²)	Motor Length (in / mm)	Motor Weight (lb / kg)	Continuous Stall Torque to Inertia Ratio (radians/sec ²)	Moment of Inertia (lb-in-sec ² / kg-m ²)	Motor Length (in / mm)	Motor Weight (lb / kg)
MAC-DE003A1	4.3 0.49	30,770	0.091 x 10 ⁻³ 0.103 x 10 ⁻⁴	3.39 86	2.0 0.9	24,779	0.113 x 10 ⁻³ 0.128 x 10 ⁻⁴	5.16 131	2.7 1.2
MAC-DE003A2	4.3 0.49	30,770	0.091 x 10 ⁻³ 0.103 x 10 ⁻⁴	3.39 86	2.0 0.9	24,779	0.113 x 10 ⁻³ 0.128 x 10 ⁻⁴	5.16 131	2.7 1.2
MAC-DE006B1	8.7 0.98	20,588	0.272 x 10 ⁻³ 0.307 x 10 ⁻⁴	3.68 94	4.2 1.9	19,048	0.294 x 10 ⁻³ 0.332 x 10 ⁻⁴	4.65 118	4.6 2.1
MAC-DE006B2	8.7 0.98	20,588	0.272 x 10 ⁻³ 0.307 x 10 ⁻⁴	3.68 94	4.2 1.9	19,048	0.294 x 10 ⁻³ 0.332 x 10 ⁻⁴	4.65 118	4.6 2.1
MAC-DE008C1	17 1.9	21,320	0.394 x 10 ⁻³ 0.446 x 10 ⁻⁴	4.47 114	5.7 2.6	20,192	0.416 x 10 ⁻³ 0.470 x 10 ⁻⁴	5.43 138	6.2 2.8
MAC-DE011C2	17 1.9	27,919	0.394 x 10 ⁻³ 0.446 x 10 ⁻⁴	4.47 114	5.7 2.6	26,442	0.416 x 10 ⁻³ 0.470 x 10 ⁻⁴	5.43 138	6.2 2.8
MAC-DE021D2	32 3.6	9,417	2.23 x 10 ⁻³ 2.52 x 10 ⁻⁴	4.65 118	13 5.9	9,292	2.26 x 10 ⁻³ 2.55 x 10 ⁻⁴	5.59 142	13.7 6.2
MAC-DE042E2	63 7.1	9,677	4.34 x 10 ⁻³ 4.91 x 10 ⁻⁴	5.75 146	18 8.2	9,633	4.36 x 10 ⁻³ 4.93 x 10 ⁻⁴	6.69 170	19.0 8.6
MAC-DA030F	66 7.8	16,185	1.73 x 10 ⁻³ 1.95 x 10 ⁻⁴	7.60 193	13 5.9	15,217	1.84 x 10 ⁻³ 2.08 x 10 ⁻⁴	8.15 207	14.3 6.5
MAC-DA055G	66 7.8	18,605	3.01 x 10 ⁻³ 3.40 x 10 ⁻⁴	9.53 242	19 8.6	17,949	3.12 x 10 ⁻³ 3.53 x 10 ⁻⁴	10.08 256	19.8 9.0
MAC-DA090H	177 20	11,097	7.84 x 10 ⁻³ 8.86 x 10 ⁻⁴	9.33 237	31 14	10,943	7.95 x 10 ⁻³ 8.98 x 10 ⁻⁴	9.88 251	32.0 14.5
MAC-DA110J	177 20	11,089	10.1 x 10 ⁻³ 11.5 x 10 ⁻⁴	10.79 274	38 17	10,874	10.3 x 10 ⁻³ 11.6 x 10 ⁻⁴	11.34 288	38.6 17.5
MAC-DA140K	177 20	11,200	12.5 x 10 ⁻³ 14.2 x 10 ⁻⁴	12.36 314	44 20	11,024	12.7 x 10 ⁻³ 14.4 x 10 ⁻⁴	12.91 328	45.2 20.5
MAC-DB025L	39 4.4	3,106	8.05 x 10 ⁻³ 9.10 x 10 ⁻⁴	6.93 176	17 7.7	3,071	8.14 x 10 ⁻³ 9.20 x 10 ⁻⁴	7.48 190	17.4 7.9
MAC-DB055M	112 13	3,813	13.9 x 10 ⁻³ 15.8 x 10 ⁻⁴	7.83 199	21 9.5	3,786	14.0 x 10 ⁻³ 15.8 x 10 ⁻⁴	8.39 213	22.0 10.0
MAC-DB080N	112 13	3,737	19.8 x 10 ⁻³ 22.4 x 10 ⁻⁴	8.78 223	26 12.0	3,719	19.9 x 10 ⁻³ 22.5 x 10 ⁻⁴	9.33 237	26.5 12.0
MAC-DB100P	380 43	2,914	35.0 x 10 ⁻³ 39.5 x 10 ⁻⁴	8.54 217	42 19.0	2,914	35.0 x 10 ⁻³ 39.5 x 10 ⁻⁴	9.09 231	43.0 19.5
MAC-DB200Q	380 43	4,118	47.6 x 10 ⁻³ 53.7 x 10 ⁻⁴	9.57 243	52 24	4,118	47.6 x 10 ⁻³ 53.8 x 10 ⁻⁴	10.12 257	51.8 23.5
MAC-DB300R	380 43	4,498	66.7 x 10 ⁻³ 75.3 x 10 ⁻⁴	10.91 277	63 29	4,498	66.7 x 10 ⁻³ 75.4 x 10 ⁻⁴	11.46 291	63.9 29.0
MAC-DB330S	646 73	4,026	85.7 x 10 ⁻³ 96.8 x 10 ⁻⁴	12.24 311	77 35	4,026	85.7 x 10 ⁻³ 96.8 x 10 ⁻⁴	12.80 325	79.3 36.0
MAC-DB465T	646 73	3,814	118 x 10 ⁻³ 133 x 10 ⁻⁴	15.16 385	100 45.4	3,814	118 x 10 ⁻³ 133 x 10 ⁻⁴	15.71 399	110.2 50.0
MAC-DB700U	744 84	2,548	261 x 10 ⁻³ 295 x 10 ⁻⁴	15.08 383	143 64.9	2,548	261 x 10 ⁻³ 295 x 10 ⁻⁴	15.63 397	144.4 65.5

⁽¹⁾Caution: The built-in fail-safe brake is designed for holding and not for decelerating the motor. In normal operation the brake should be applied only after the motor is stopped. Fail-safe brakes are useful in applications when a servomotor is used to control a vertical axis. A servomotor with a fail-safe brake prevents the moveable part from dropping due to gravitation when the system power is turned OFF.

DE003A1 & DE003A2 Outline Drawings

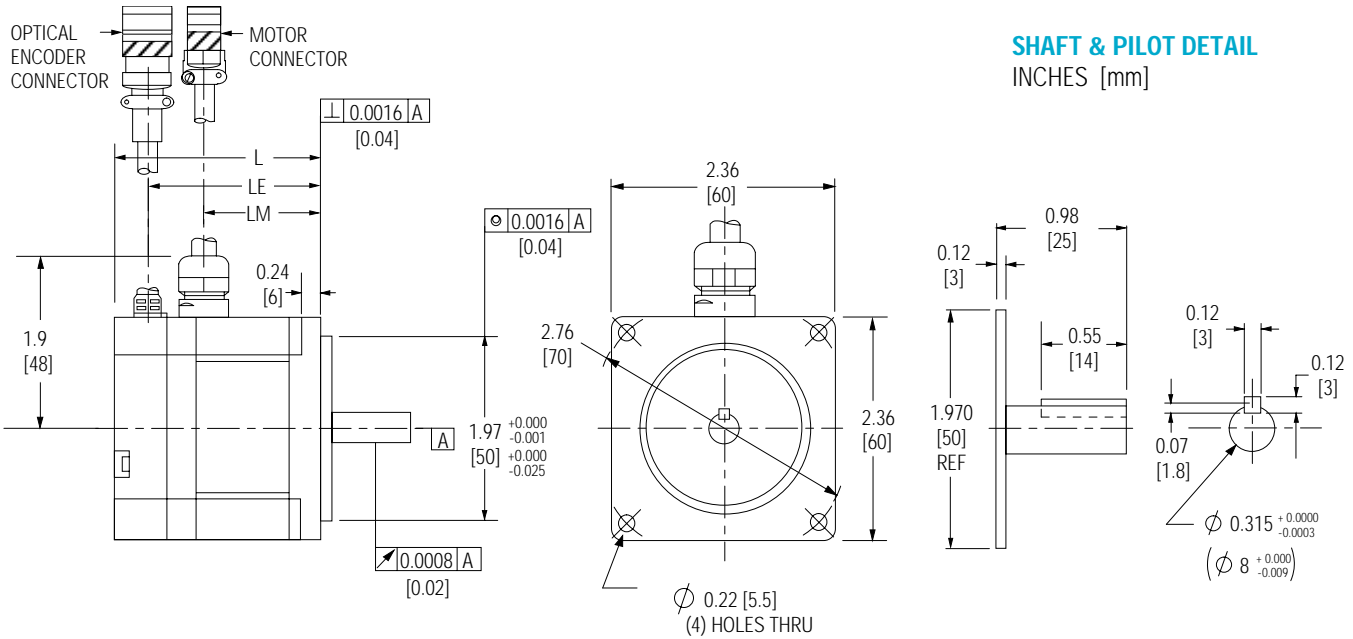

Dimensions	L	LE	LM
MAC-DE003A1	2.3 [57] 4.1 [102]	1.9 [48] 3.7 [94]	1.3 [32]
MAC-DE003A2	2.3 [57] 4.1 [102]	1.9 [48] 3.7 [94]	1.3 [32]

Note: Minimum cable clearance from motor centerline for encoder cable is 2.8 inches (71 mm); for motor cable is 3.8 inches (97 mm). Cable lengths to connector approximately 11 inches (280 mm).

For length of models with brake and absolute encoder options selected, see page 11. Call for design details.

All dimensions in inches [millimeters]

DE006B1, DE006B2, DE008C1 & DE011C2 Outline Drawings

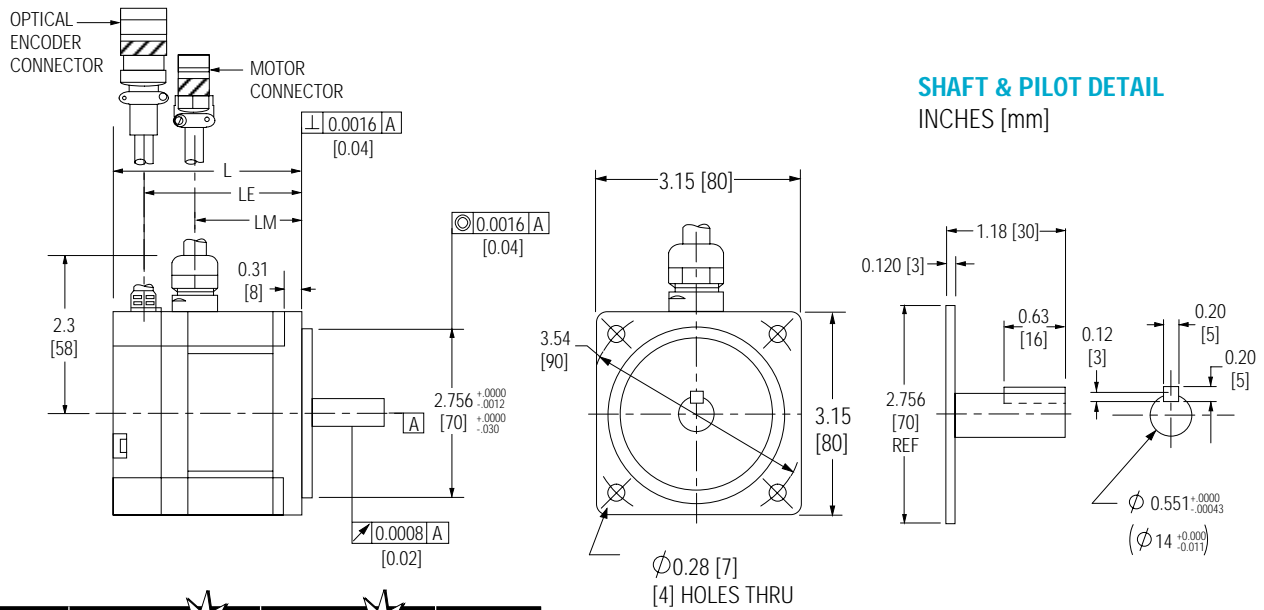

Dimensions	L	LE	LM
MAC-DE006B1	2.5 [63] 3.5 [87]	2.1 [53] 2.9 [75]	1.6 [40]
MAC-DE006B2	2.5 [63] 3.5 [87]	2.1 [53] 2.9 [75]	1.6 [40]
MAC-DE008C1	3.3 [84] 4.2 [107]	2.9 [73] 3.7 [95]	2.4 [60]
MAC-DE011C2	3.3 [84] 4.2 [107]	2.9 [73] 3.7 [95]	2.4 [60]

Note: Minimum cable clearance from motor centerline for encoder cable is 3.2 inches (81 mm); for motor cable is 4.2 inches (107 mm). Cable lengths to connector approximately 11 inches (280 mm).

DE021D2 & DE042E2 Outline Drawings

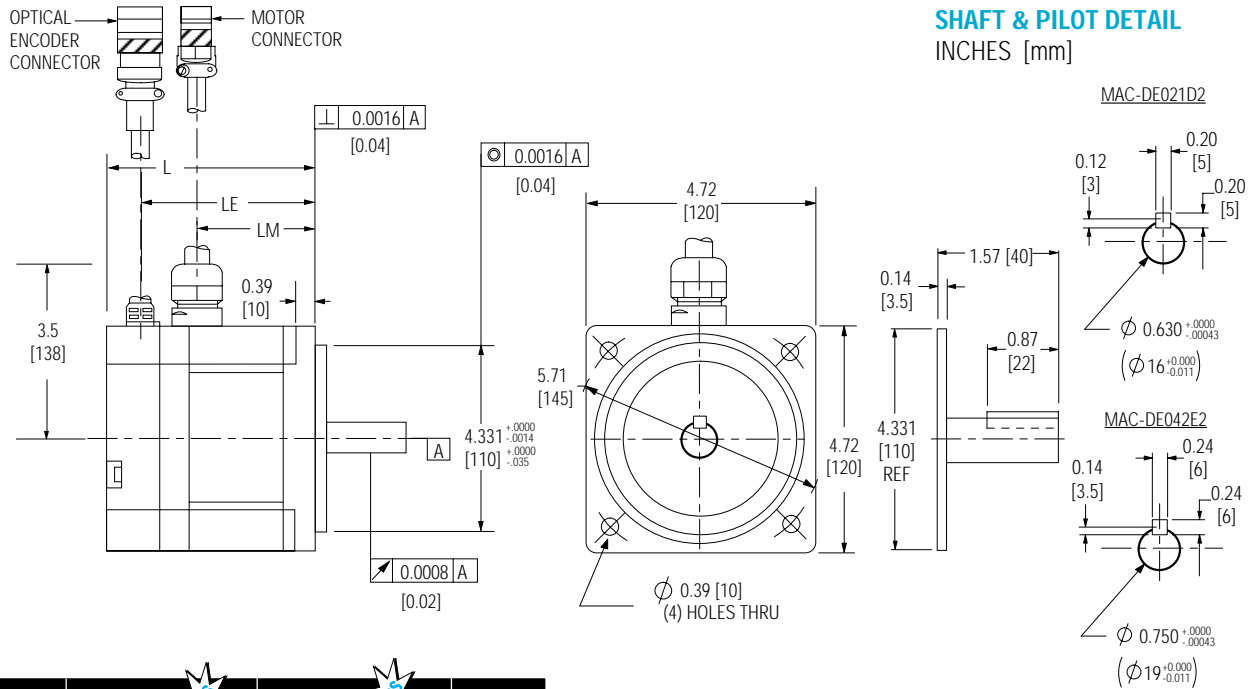

Dimensions	L	LE	LM
MAC-DE021D2	3.2 [82] 4.2 [106]	2.8 [72] 3.5 [89]	2.2 [56]
MAC-DE042E2	4.3 [110] 5.3 [134]	3.9 [100] 4.7 [120]	3.3 [84]

Note: Minimum cable clearance from motor centerline for encoder cable is 4.0 inches (102 mm); for motor cable is 5.0 inches (127 mm). Cable lengths to connector approximately 11 inches (280 mm).

For length of models with brake and absolute encoder options selected, see page 11. Call for design details.

All dimensions in inches [millimeters]

DA030F & DA055G Outline Drawings

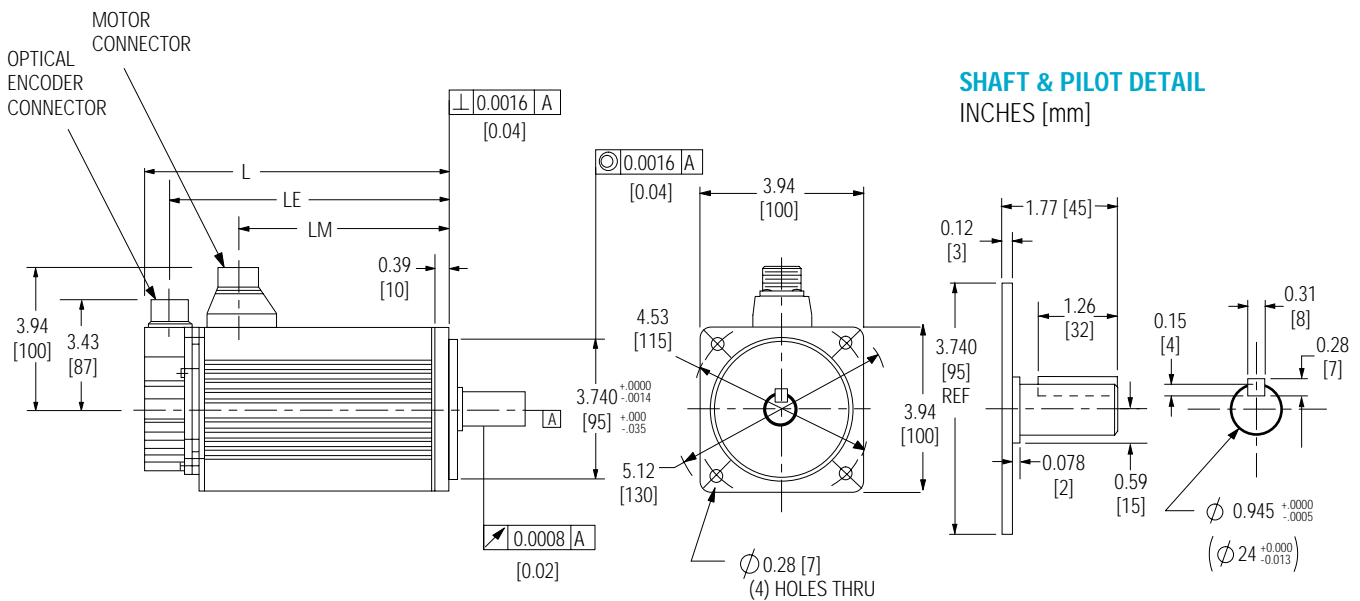

Dimensions	L	LE	LM
MAC-DA030F	5.9 [150] 6.4 [163]	5.1 [130] 5.6 [142]	3.0 [76]
MAC-DA055G	7.8 [200] 8.4 [212]	7.0 [178] 7.5 [191]	4.9 [125]

Note: Minimum cable clearance from motor centerline for Encoder Cable is 6.2 inches (157 mm); for Motor Cable is 6.6 inches (168 mm).

DA090H, DA110J & DA140K Outline Drawings

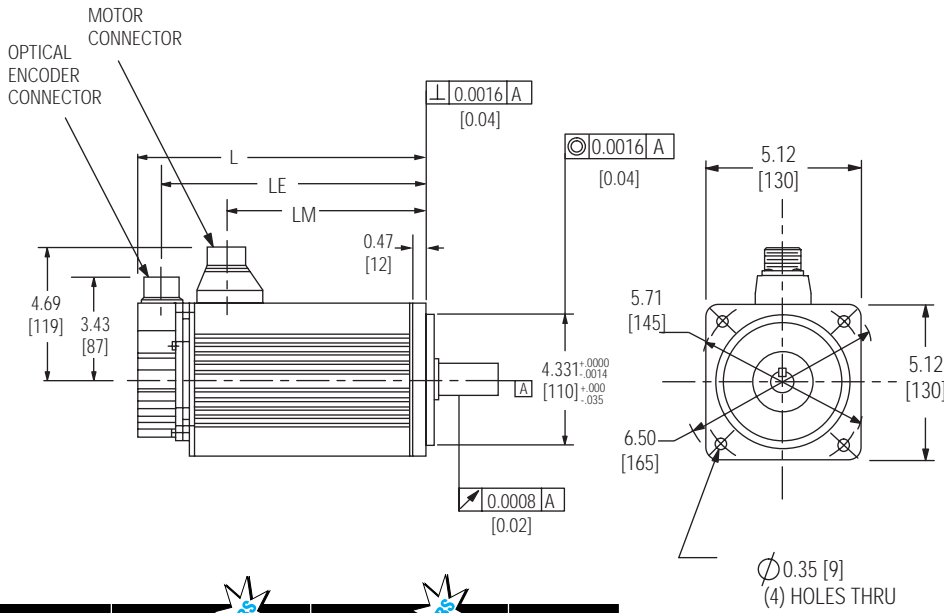

SHAFT & PILOT DETAIL INCHES [mm]

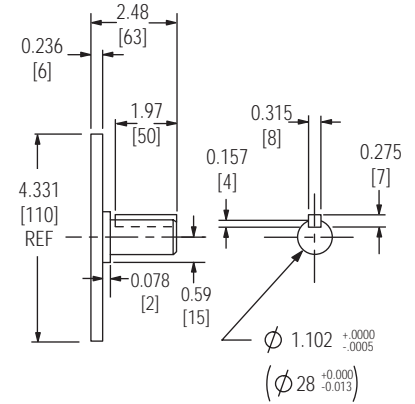

Dimensions	L	LE	LM
MAC-DA090H	7.9 [200] 8.4 [213]	7.0 [177] 7.6 [192]	4.8 [122]
MAC-DA110J	9.3 [236] 9.9 [250]	8.4 [213] 9.0 [229]	6.2 [157]
MAC-DA140K	10.9 [277] 11.5 [290]	10.0 [254] 10.6 [269]	7.8 [198]

Note: Minimum cable clearance from motor centerline for encoder cable is 6.2 inches (157 mm); for motor cable is 7.5 inches (191 mm).

For length of models with brake and absolute encoder options selected, see page 11. Call for design details.

All dimensions in inches [millimeters]

DB025L, DB055M & DB080N Outline Drawings

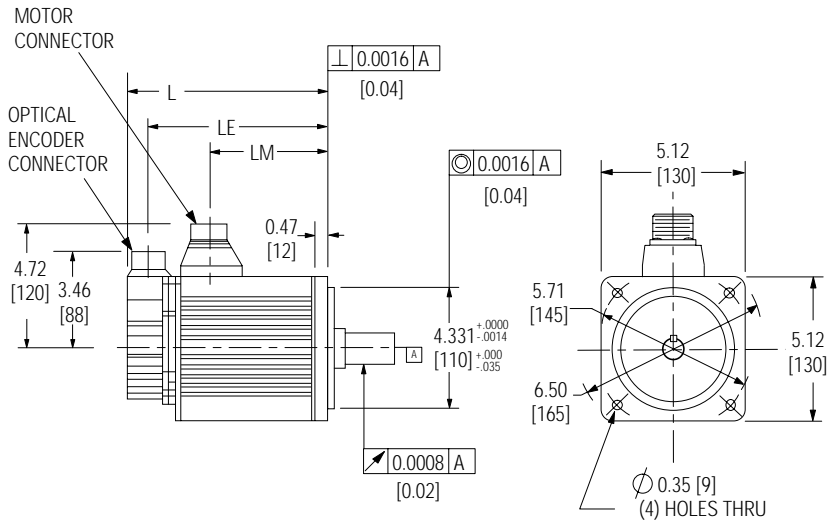

SHAFT & PILOT DETAIL INCHES [mm]

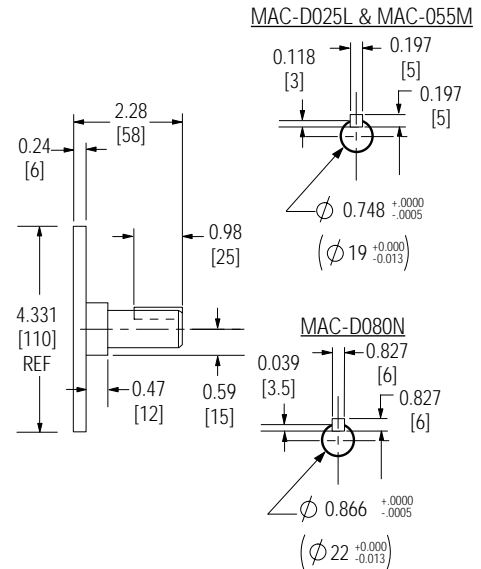

Dimensions	L	LE	LM
MAC-DB025L	5.4 [137] 6.0 [152]	4.6 [117] 5.1 [131]	2.5 [64]
MAC-DB055M	6.3 [160] 6.9 [175]	5.5 [140] 6.0 [154]	3.4 [86]
MAC-DB080N	7.3 [185] 7.9 [199]	6.4 [162] 7.0 [178]	4.4 [112]

Note: Minimum cable clearance from motor centerline for encoder cable is 6.3 inches (160 mm); for motor cable is 7.0 inches (178 mm).

DB100P, DB200Q, DB300R, DB330S & DB465T Outline Drawings

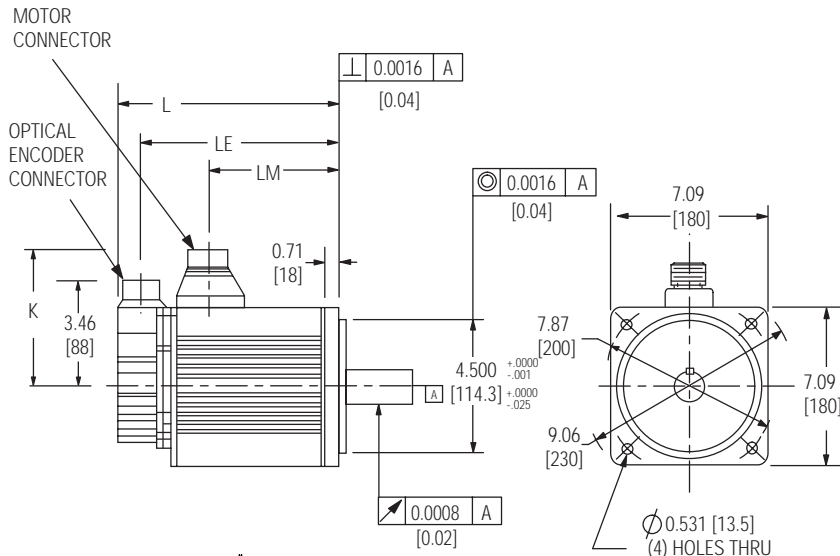

SHAFT & PILOT DETAIL INCHES [mm]

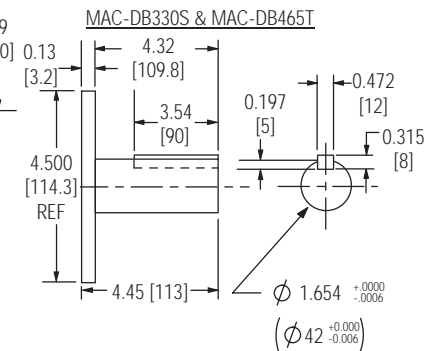
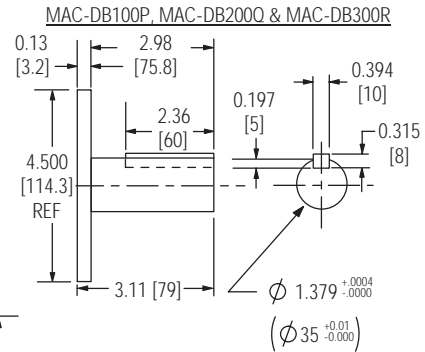

Note: Minimum cable clearance from motor centerline for encoder cable is 6.3 inches (160 mm); for motor cable is 9.5 inches (241 mm)

Dimensions	L	LE	LM	K
MAC-DB100P	6.5 [165]	7.1 [180]	5.7 [145]	5.8 [147]
MAC-DB200Q	7.5 [190]	8.2 [206]	6.7 [170]	5.8 [147]
MAC-DB300R	8.9 [226]	9.5 [240]	8.1 [205]	5.8 [147]
MAC-DB330S	10.2 [259]	10.8 [274]	9.4 [239]	5.9 [150]
MAC-DB465T	13.2 [335]	13.7 [348]	12.3 [312]	5.9 [150]

For length of models with brake and absolute encoder options selected, see page 11. Call for design details.

All dimensions in inches [millimeters]

DB700U Outline Drawing

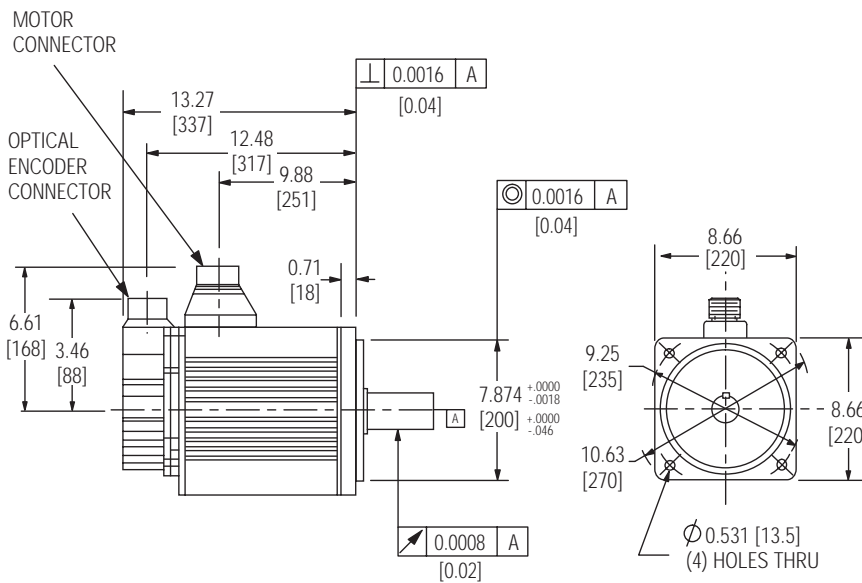

SHAFT & PILOT DETAIL INCHES [mm]

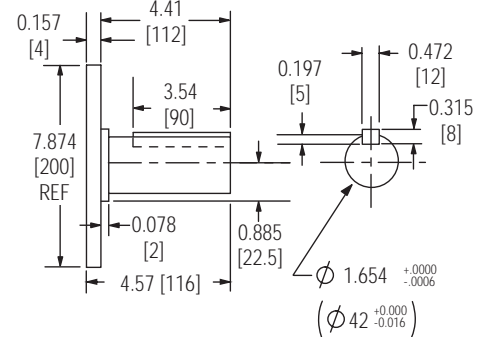

Note: Minimum cable clearance from motor centerline for encoder cable is 6.3 inches (160 mm); for motor cable is 9.5 inches (241 mm)

Dimensions	L	LE	LM
MAC-DB700U	13.3 [337]	13.9 [352]	9.8 [249]

Servomotor Connectors

MOTOR / POWER RECEPTACLES

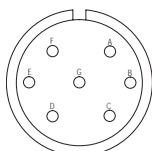

Fig. W

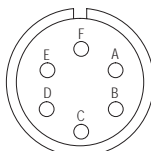

Fig. Y

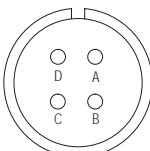

Fig. X

A	1	Phase U	RED
B	2	Phase V	WHT
C	3	Phase W	BLU
D	4	Ground	GRN
E	5	Brake Term	RED
F	6	Brake Term	BLK

Connector Type	Manufactured by
97F...	Deiichi Deshi
CE05...	Deiichi Deshi
JL04...	Japan Aviation Ind.
MS....	Amphenol

BRAKE CONNECTOR (Figure B)

A	Brake Term
B	Brake Term
C	--

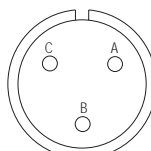

Fig. B

ENCODER FEEDBACK RECEPTACLES (Figure U)

A	1	Channel B output
B	2	Channel B/ output
C	3	Channel A output
D	4	Channel A/ output
E	5	Channel Z output
F	6	Channel Z/ output
G	8	0V
H	7	+5VDC
J	12	Case Ground
N	11	Reset
P	10	0V (battery)
R	9	+3.6V(battery)
T, S, M, L, K -- No connection		

Terminals used for absolute encoders only.

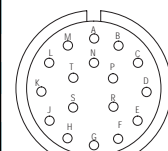

Fig. U

MOTOR / FEEDBACK / OPTION -- MATING CONNECTOR CHART

MOTOR TYPE	FIG	MOTOR/POWER	MATING	FIG	FEEDBACK	MATING
Motors (incremental or absolute feedback) All of MAC-DE series motors	Y	MS-3101A18-12P	MS-3106F18-12S	U	MS-3101A20-29P	MS-3106F20-29S
MAC-DA030F, DA055G, DB025L, DB055M, DB080N	X	MS-3102A18-10P	MS-3106F18-10S	U	MS-3102A20-29P	MS-3106F20-29S
MAC-DA090H, DA110J, DA140K, DB100P, DB200Q, DB300R	X	MS-3102A22-22P	MS-3106F22-22S	U	MS-3101A20-29P	MS-3106F20-29S
MAC-DB330S, DB465T & DB700U	X	MS-3102A32-17P	MS-3106F32-17S	U	MS-3101A20-29P	MS-3106F20-29S
Motors with IP-67						
MAC-DA030F, DA055G, DB025L, DB055M, DB080N	X	CE05-2A18-10PD	MS3106A18-10S(D190)	U	97F3102A20-29P	MS-3106F20-29S(D190)
MAC-DA090H, DA110J, DA140K, DB100P, DB200Q, DB300R	X	JL04HV-2E22-22PE-B	JL04-6A22-22S	U	97F3102A20-29P	MS-3106F20-29S(D190)
MAC-DB330S, DB465T & DB700U	X	JL04V-2E32-17PE-B	JL04-6A32-17SE	U	97F3102A20-29P	MS-3106F20-29S(D190)
Motors with Fail-safe Brake						
MAC-DA030F, DA055G, DB025L, DB055M, DB080N	W	MS-3102A20-15P	MS-3106F20-15S	U	MS-3101A20-29P	MS-3106F20-29S
MAC-DA090H, DA110J, DA140K, DB100P, DB200Q, DB300R	W	MS-3102A24-10P	MS-3106F24-10S	U	MS-3101A20-29P	MS-3106F20-29S
MAC-DB330S, DB465T & DB700U	X	MS-3102A32-17P*	MS-3106F32-17S*	U	MS-3101A20-29P	MS-3106F20-29S
	B	MS-3102A10SL-3P*	MS-3106F10SL-3S*			
Motors with IP-67 and Fail-safe Brake						
MAC-DA030F, DA055G, DB025L, DB055M, DB080N	W	JL04V-2E20-15PE	JL04-6A20-15SE	U	97F3102A20-29P	MS-3106F20-29S(D190)
MAC-DA090H, DA110J, DA140K, DB100P, DB200Q, DB300R	W	JL04V-2E24-10PE-B	JL04-6A22-22S	U	97F3102A20-29P	MS-3106F20-29S(D190)
MAC-DB330S, DB465T & DB700U	X	JL04V-2E32-17PE-B*	JL04-6A32-17SE*	U	97F3102A20-29P	MS-3106F20-29S(D190)
	B	CE05-2A10SL-3PC*	MS-3106A10SL-3S(D190)*			

* Brake option requires separate motor and brake cables (both incremental and absolute).

D-Series Encoder and Motor Cables

Standard	IP-67 Sealing	Brake Option	Brake w/IP-67 Sealing
CBL-DMSW/X			
CBL-DMSW/X	CBL-DMSWV/X		
CBL-DEMSW1/X		CBL-DEMSWB1/X	
CBL-DMSW1/X	CBL-DMSWV1/X	CBL-DMSWB1/X	CBL-DMSWVB1/X
CBL-DMSWT1/X	CBL-DMSWVT1/X	CBL-DMSWBT1/X	CBL-DMSWVB1/X
CBL-DMSWT2/X	CBL-DMSWVT2/X	CBL-DMSWBT2/X	CBL-DMSWVB2/X
CBL-DMSWT3/X	CBL-DMSWVT3/X	CBL-DMSWBT3/X	CBL-DMSWVB3/X
CBL-DMSW4/X	CBL-DMSWV4/X	CBL-DMSWB4/X	CBL-DMSWVB4/X
CBL-DMSWT4/X	CBL-DMSWVT4/X	CBL-DMSWBT4/X	CBL-DMSWVB4/X
CBL-DMSWT5/X	CBL-DMSWVT5/X	CBL-DMSWT5/X & CBL-DMACB/X	CBL-DMSWVT5/X & CBL-DMACVB/X
CBL-DMSWT6/X	CBL-DMSWVT6/X	CBL-DMSWT6/X & CBL-DMACB/X	CBL-DMSWVT6/X & CBL-DMACVB/X

Encoder cable for all MAC-DE motors, 1-150 ft
Encoder Cable for MAC-DA & DB motors, 1-150 ft
Motor cables for all MAC-DE motors, 1-150 ft
Motor cables for MAC-DA030, DA055, DB025, DB055 & DB080 motors, 1-150 ft. For use with ORMEC drives (SW210 - SW220, G10 - G20 and SMS-210 - SMS-220)
Motor cables for MAC-DA055, 1-150 ft. For use with ORMEC drives (SW225, G25 and SMS-225).
Motor cables for MAC-DA090, DA110 & DB200, 1-150 ft. For use with ORMEC drives (SW225 -SW260, G25 -G60 and SMS-225 - SMS-260).
Motor cables for MAC-DA140 & DB300, 1-150 ft. For use with ORMEC drives (SW235 -SW260, G35 -G60 and SMS-235 - SMS-260).
Motor cables for MAC-DB100, 1-150 ft. For use with ORMEC drives (SW220, G20 and SMS-220).
Motor cables for MAC-DB100, 1-150 ft. For use with ORMEC drives (SW225, G25 and SMS-225).
Motor cables for MAC-DB330, 1-150 ft. For use with ORMEC drives (SW260, G60 and SMS-260).
Motor cables for MAC-DB465 & DB700, 1-150 ft. For use with ORMEC drives (SW260, G60 and SMS-260).

Note: For all cables above, specify length of the cable by adding the numerical length in the "X" placeholder in the Model Number.