

ACCU ELECTRIC MOTORS INC

USA: (888) 932-9183

CANADA: (905) 829-2505

- ✓ Over 100 years cumulative experience
- ✓ 24 hour rush turnaround / technical support service
- ✓ Established in 1993



The leading independent repairer of servo motors and drives in North America.

Visit us on the web:

www.servo-repair.com

www.servorepair.ca

www.ferrocontrol.com

www.sandvikrepair.com

www.accuelectric.com

Scroll down to view your document!

For 24/7 repair services :

USA: 1 (888) 932 - 9183

Canada: 1 (905) 829 -2505

Emergency After hours: 1 (416) 624 0386

Servicing USA and Canada

Lexium BPH series servo motors

Wiring the Motor and Drive Connectors
Assembly Instruction

Edition 2.2001



b



GENERAL WARNINGS



*All the international, state, regional and local standards must be complied with during the installation and during the use of this product.
Only properly qualified personnel having extensive knowledge in servomotor technology should install, commission and/or maintain the product.*



*These servomotors are suitable for operation at a temperature $>100^{\circ}\text{C}$.
Safeguards must therefore be used to provide protection against accidental or direct contact with the motor housing .*



*The servomotors with keyed shaft must never be rotated under power unless connected to the mechanics of the machine.
The key could come out from the shaft and due to the centrifugal force could cause damage to personnel and machines.*



The motors assembled vertically (with the upwards shaft) may be seriously damaged by liquids collected next to the shaft end output. Make therefore sure that there is no liquid deposit next to the motor shaft end .



The holding brake is not to be considered a safety device. In the case of a vertical axis, interpose safety interlock or additional safety brakes to stop the axis from falling. It could cause damage to personnel and machines.



*If a brake is provided on the motor, no axial loadings must be applied.
If it is supplied with reverse polarity, the brake stays locked on.
If the holding brake is not being used for a long time, the oxidation of its parts may lead to a braking torque reduction.*



Use only original Schneider Electric cables. The original Schneider Electric cables have special characteristics (capacitance value...). Not to respect these characteristics can cause serious damage to servomotors.



During the servomotor installation, always make sure that the connection cable used is the one established in the reference guide. The use of an incorrect cable leads to the violation of the international standards.



Always disable the system and disconnect the cables from the motor before carrying out the connector orientation (turnable each 90° by the customer).

GENERAL INDEX

Wiring the motor and drive power connector	4
BPH055S motor power connector	4
BPH055S drive power connector	5
BPH075÷1904K motor power connector	6
BPH075÷1904K drive power connector	7
BPH1907K / AK motor power connector	8
BPH1907K / AK drive power connector	9
Wiring the motor and drive resolver connector	10
BPH055S motor resolver connector	10
BPH055S drive resolver connector	11
BPH075÷190 motor resolver connector	12
BPH075÷190 drive resolver connector	13
Wiring the motor and drive encoder connector	14
BPH075÷190 motor encoder connector	14
BPH075÷190 drive encoder connector	15

BPH055S - Wiring the motor power connector

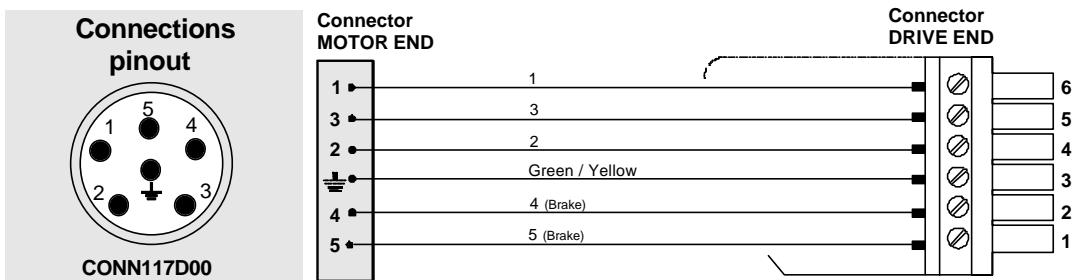
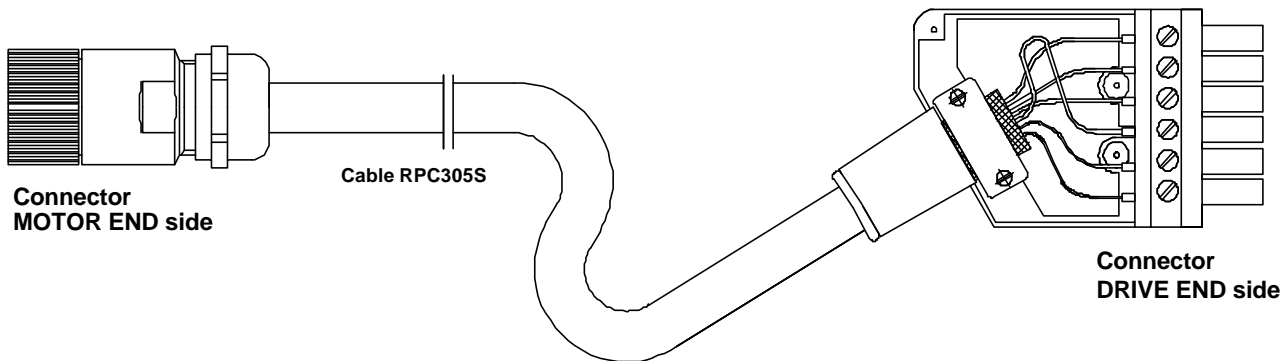

If you constructor your own motor power connector with shielding, please do so according to the followig procedure.

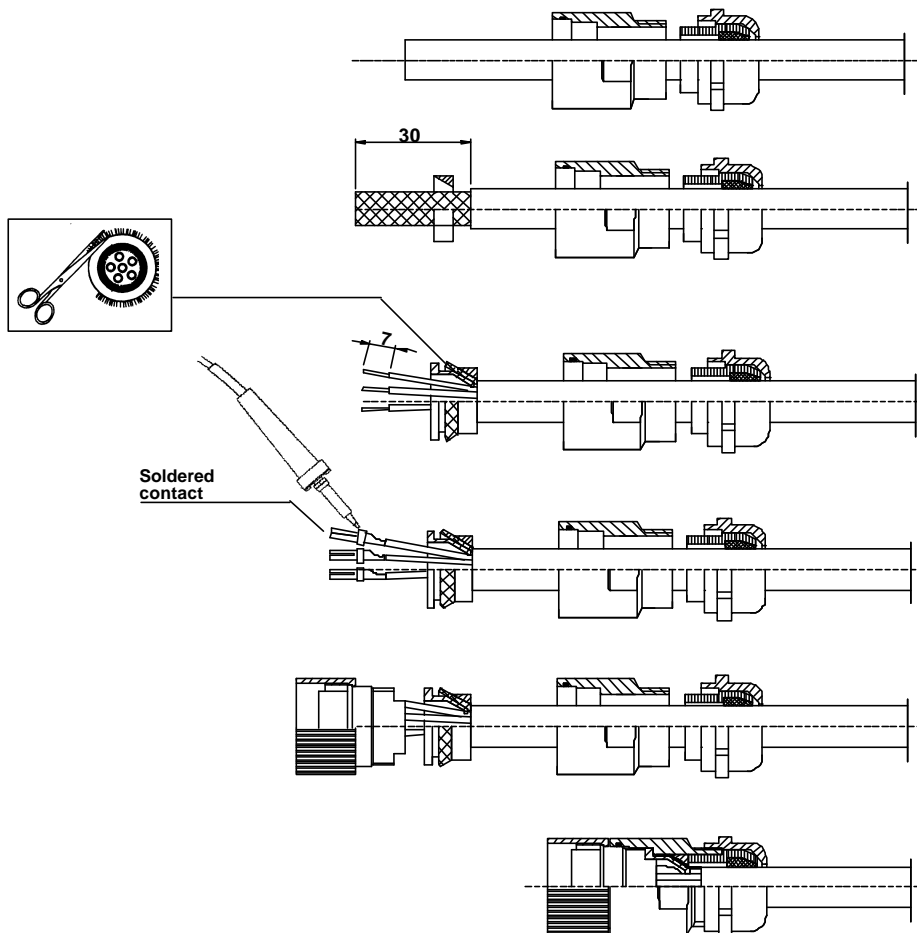

BPH055S - Wiring the drive power connector

Connector
MOTOR END

Connector
DRIVE END

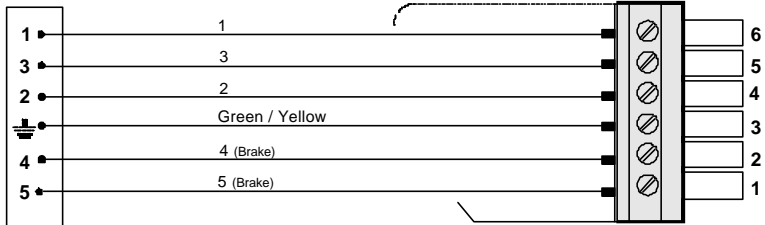

Connections
pinout

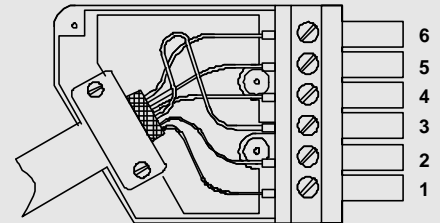

AEOCON009

If you constructor your own drive power connector with shielding, please do so according to the following procedure.

STEP	ACTION
1	Carefully remove about 70mm of the outer jacket while taking care not to damage the braided shield.
2	Push the outer braided shield back over the cable jacket.
3	Position the shielding for the brake wires over the outer shielding braid and ensure good electrical contact.
4	Push the filling wires and protective cloth back over the shielding.
5	Push the shrink tubing (30mm long) over the shielding and leave about 15mm exposed.
6	Use a hot-air blower to shrink the tubing then shorten the wires for U,V,W to 45mm and those for BRAKE to 55mm.
7	Carefully remove about 10mm of the ends of the wires while taking care not to damage the copper strands.
8	Attach crimp ferrules to the ends of the wires.
9	Place the shielding plate in the connector housing and push the contact tabs into the PE terminal clamp of the connector.
10	Attach the cable with the strain relief.
11	Ensure the clamping loop of the strain relief sits properly on the shielding braid.
12	Push the wire ferrules into the corresponding terminals in the connector and tighten.

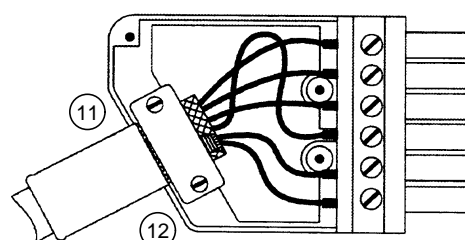
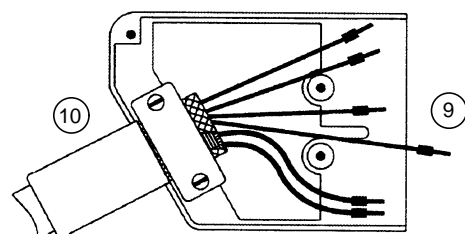
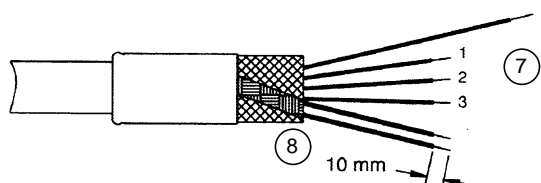
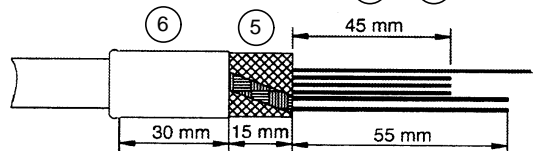
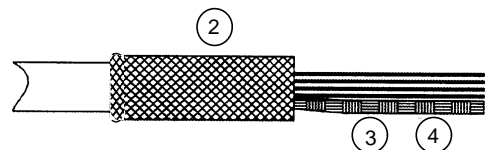
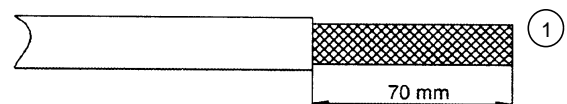

BPH075÷1904K - Wiring the motor power connector

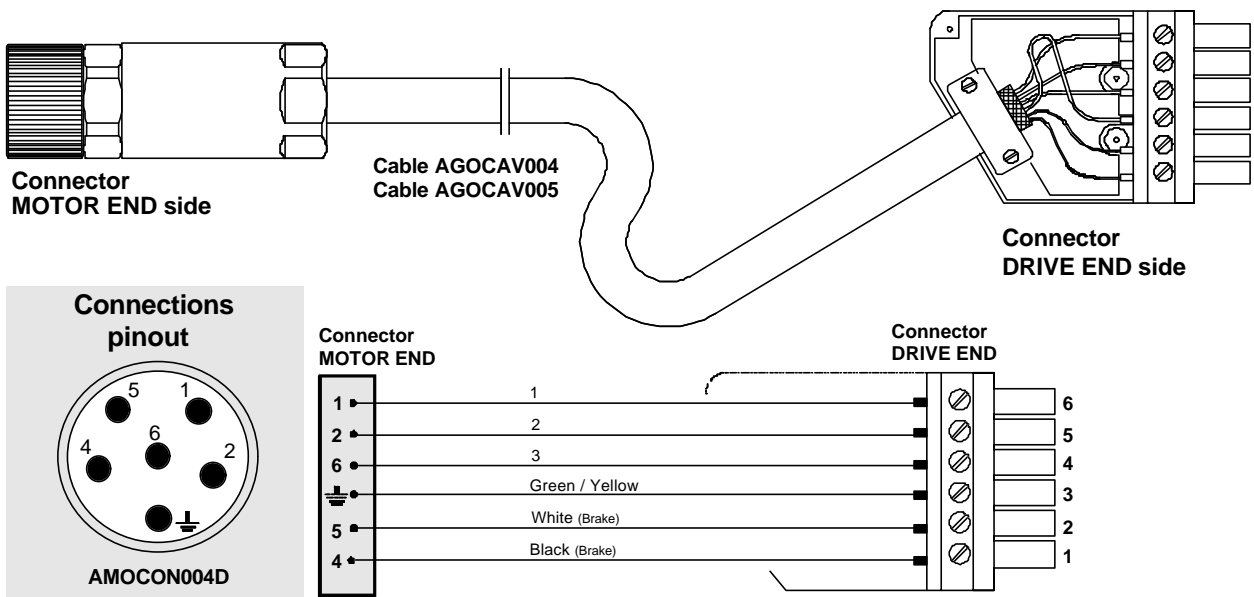

If you constructor your own motor power connector with shielding, please do so according to the followig procedure.

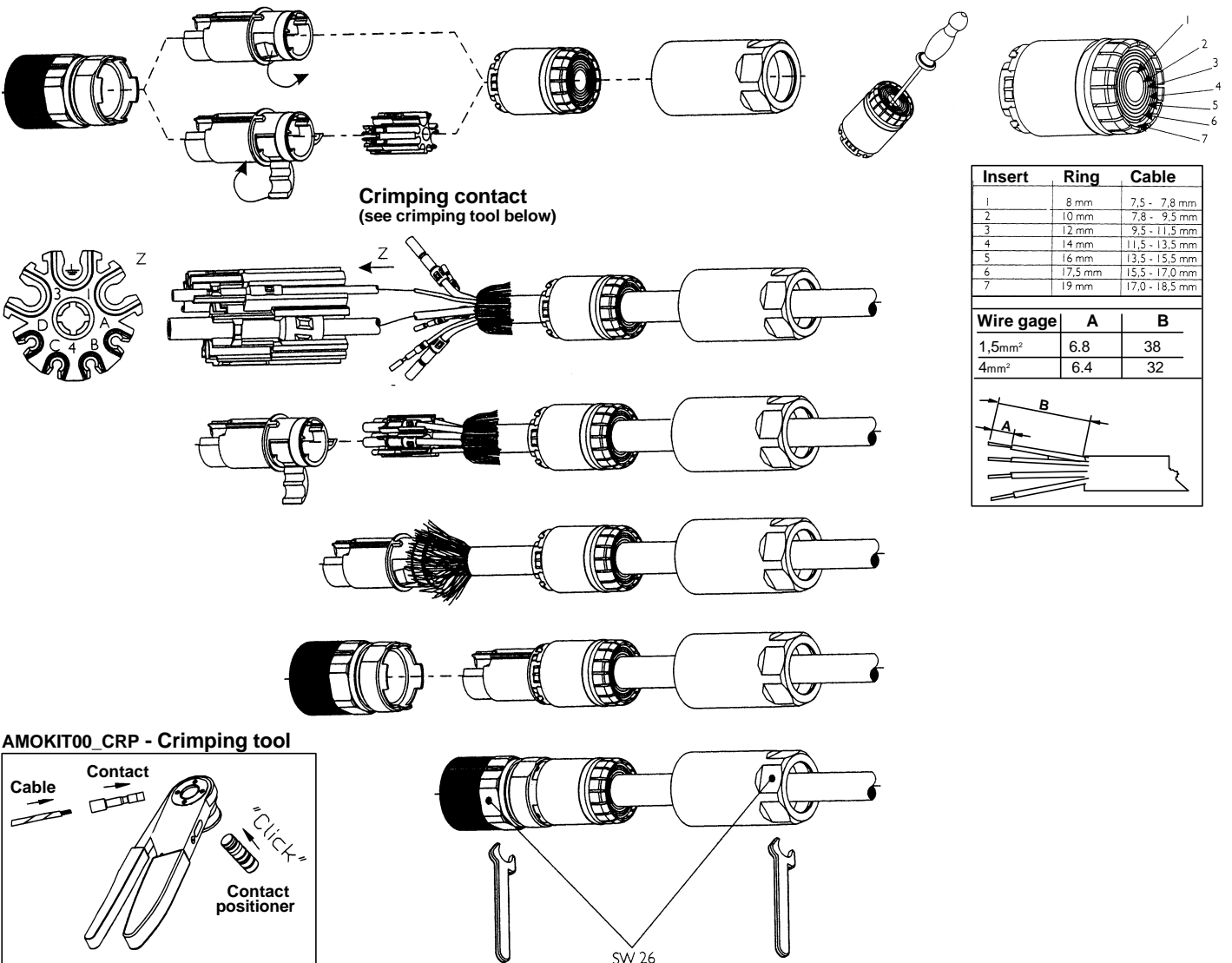

BPH075÷1904K - Wiring the drive power connector

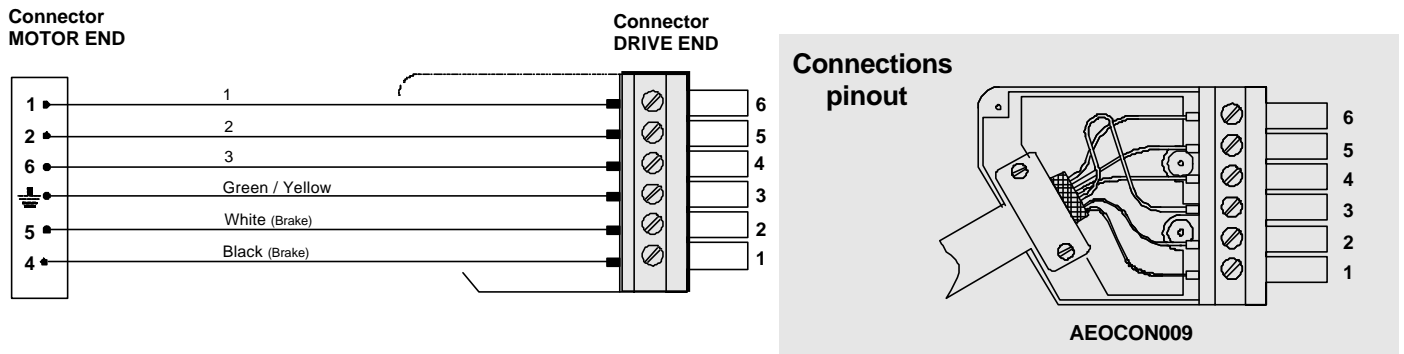

If you constructor your own drive power connector with shielding, please do so according to the followig procedure.

STEP	ACTION
1	Carefully remove about 70mm of the outer jacket while taking care not to damage the braided shield.
2	Push the outer braided shield back over the cable jacket.
3	Position the shielding for the brake wires over the outer shielding braid and ensure good electrical contact.
4	Push the filling wires and protective cloth back over the shielding.
5	Push the shrink tubing (30mm long) over the shielding and leave about 15mm exposed.
6	Use a hot-air blower to shrink the tubing then shorten the wires for U,V,W to 45mm and those for BRAKE to 55mm.
7	Carefully remove about 10mm of the ends of the wires while taking care not to damage the copper strands.
8	Attach crimp ferrules to the ends of the wires.
9	Place the shielding plate in the connector housing and push the contact tabs into the PE terminal clamp of the connector.
10	Attach the cable with the strain relief.
11	Ensure the clamping loop of the strain relief sits properly on the shielding braid.
12	Push the wire ferrules into the corresponding terminals in the connector and tighten.

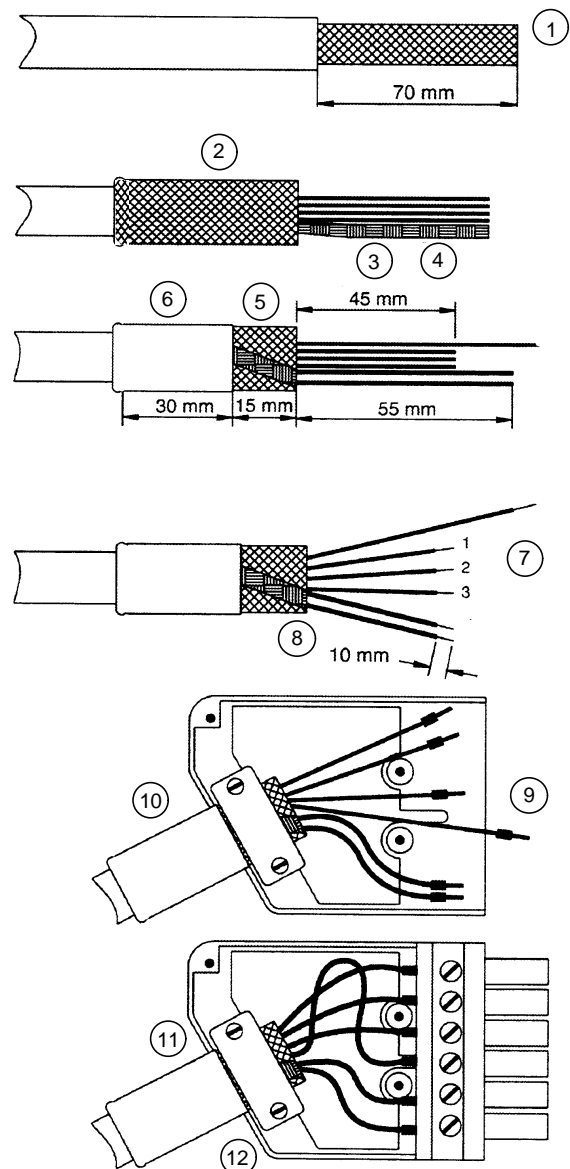

BPH1907K / AK - Wiring the motor power connector

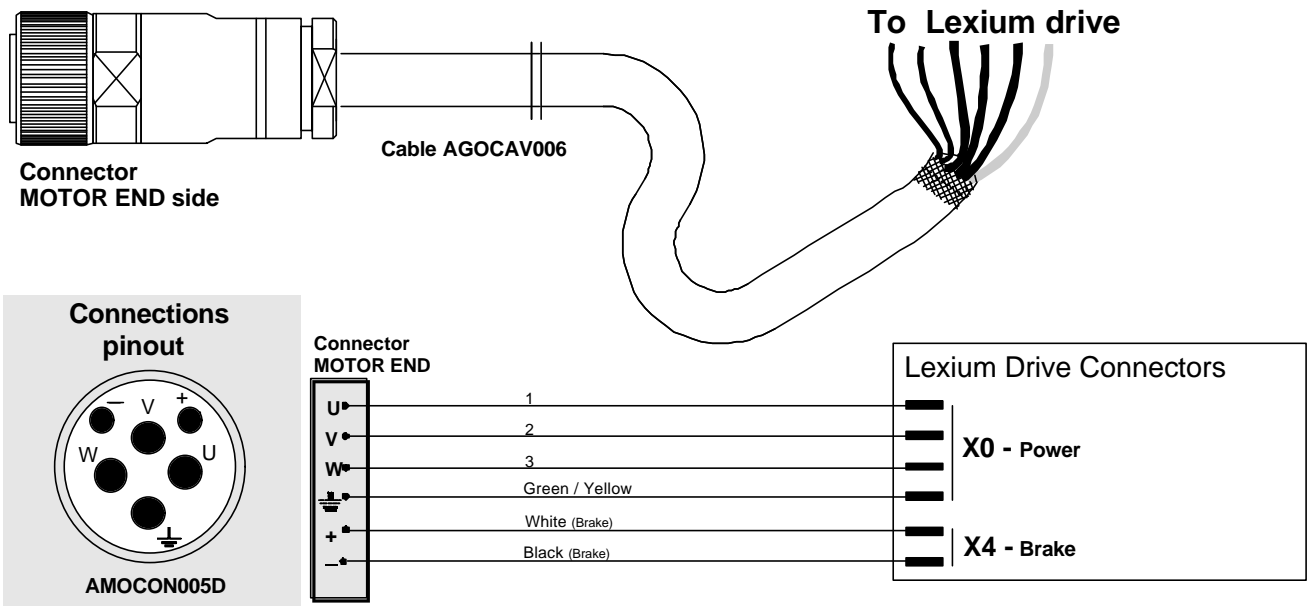

If you constructor your own motor power connector with shielding , please do so according to the followig procedure.

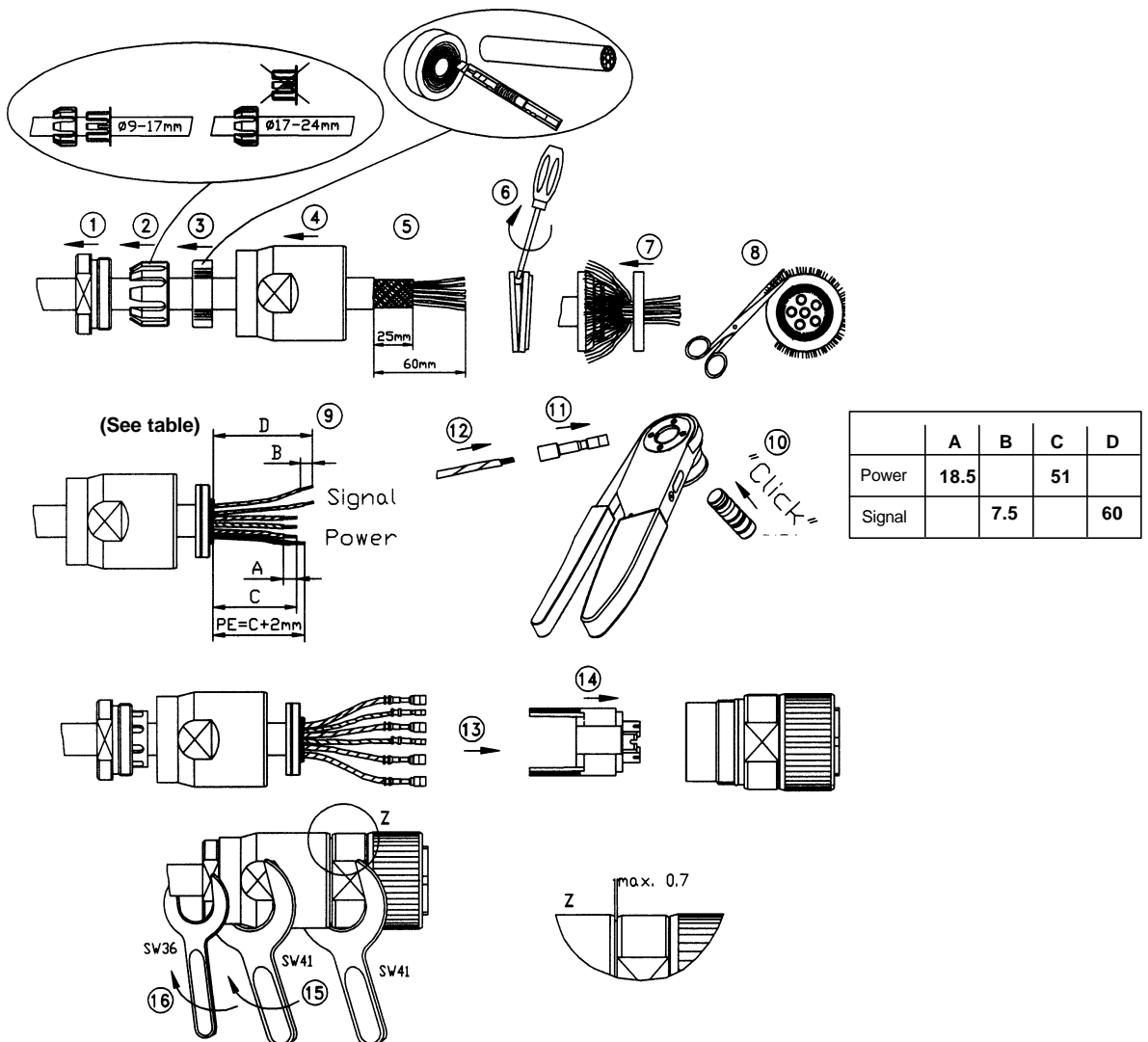

BPH1907K / AK - Wiring the drive power connector

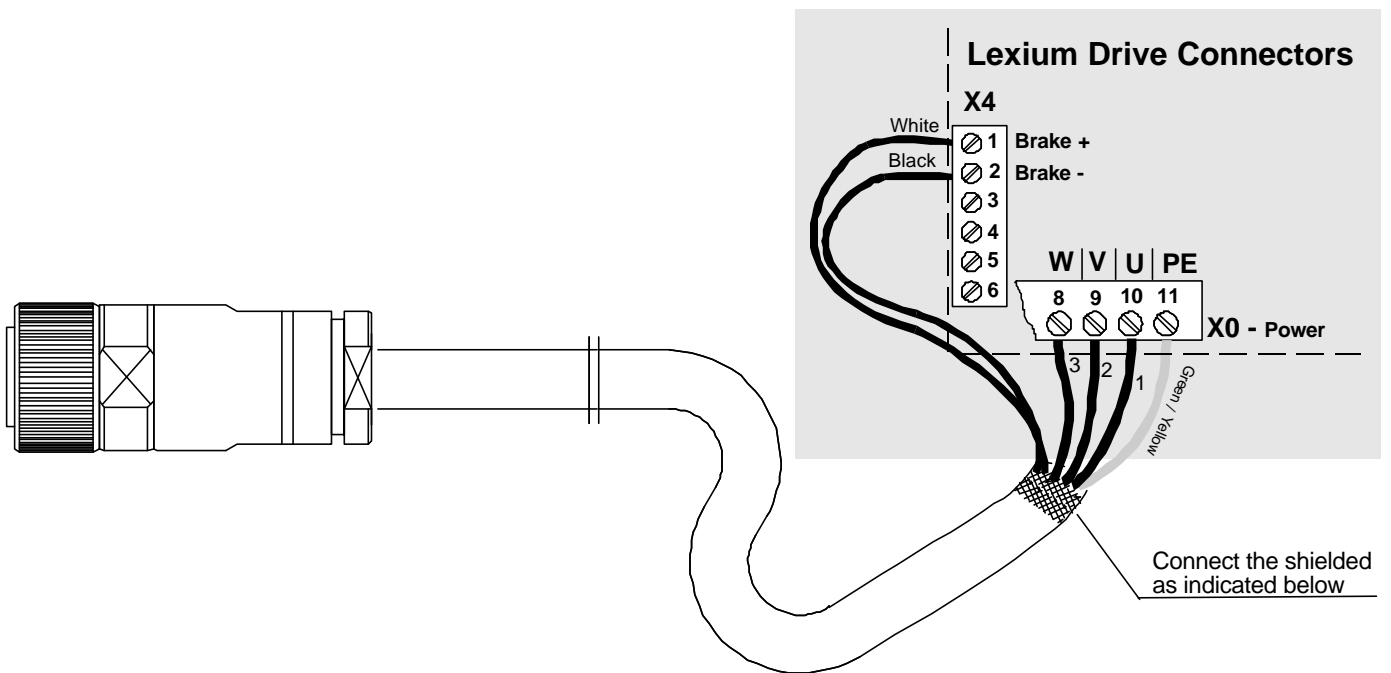

Lexium Drive

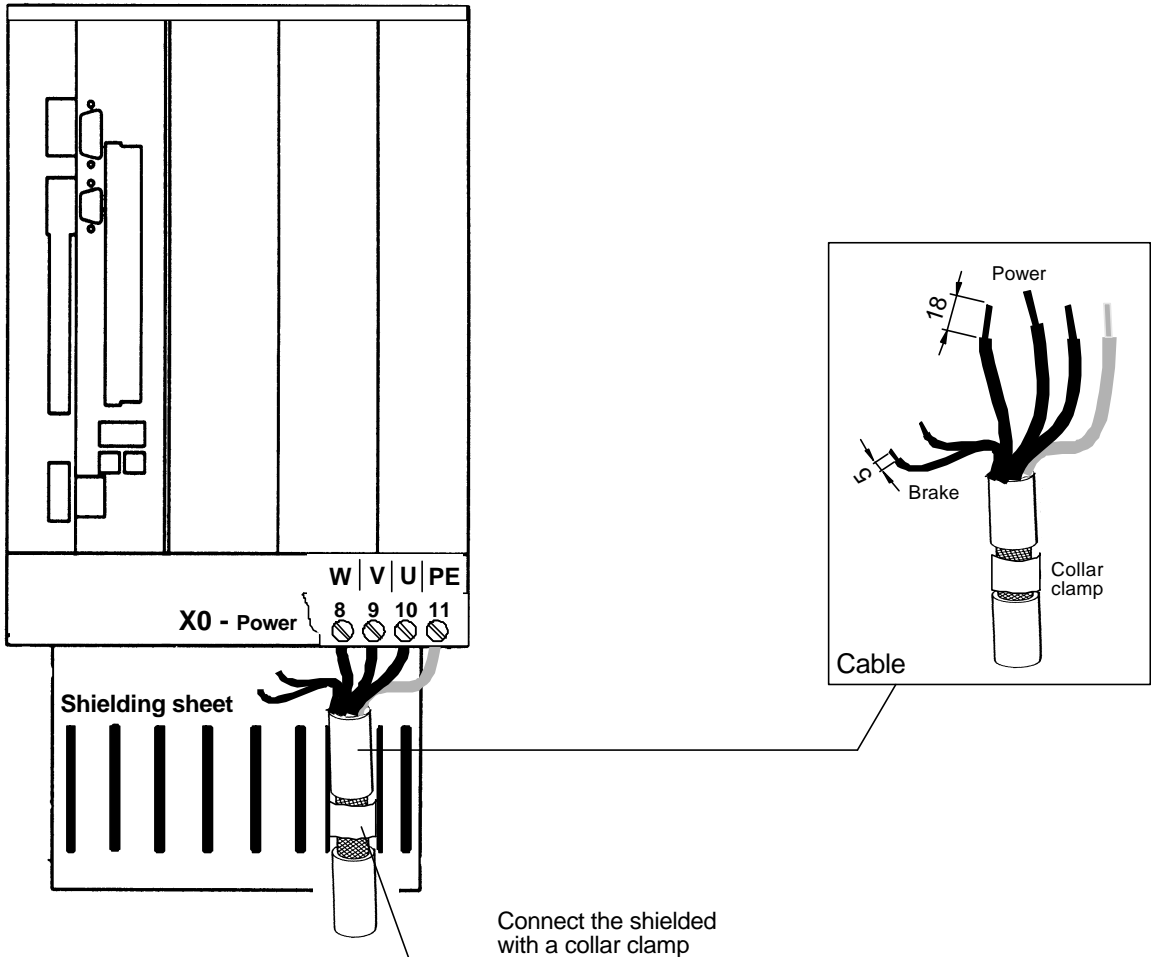

BPH055S - Wiring the motor resolver connector

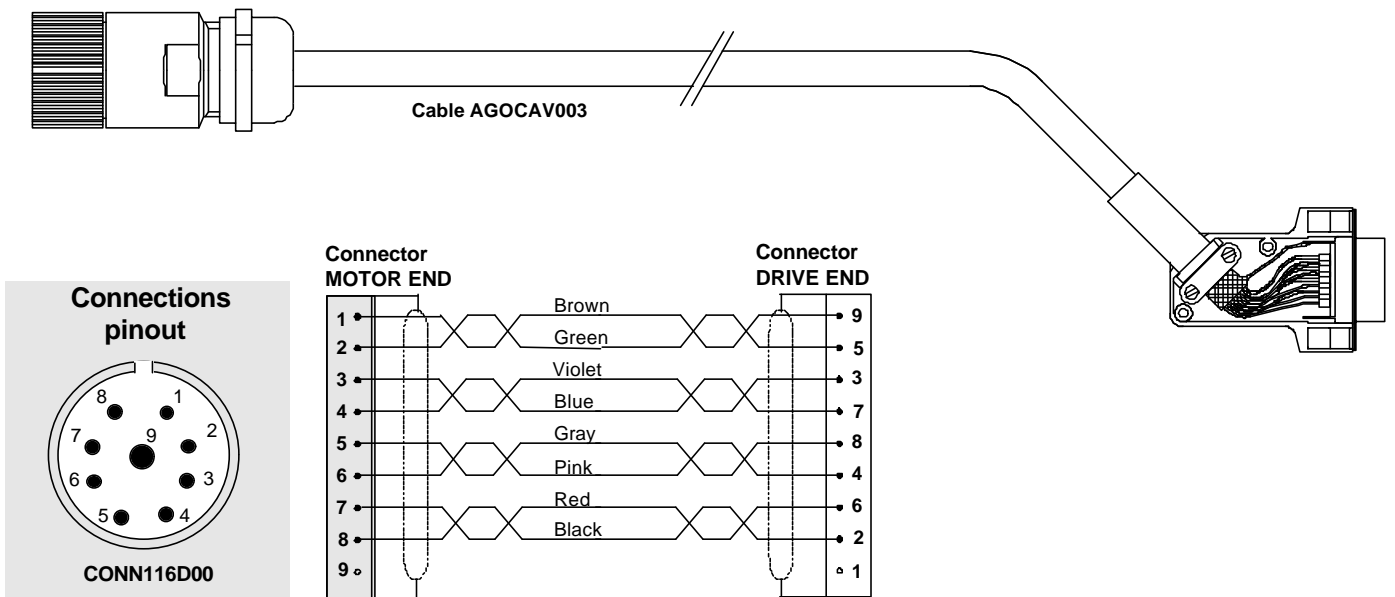

If you constructor your own motor resolver connector with shielding, please do so according to the following procedure.

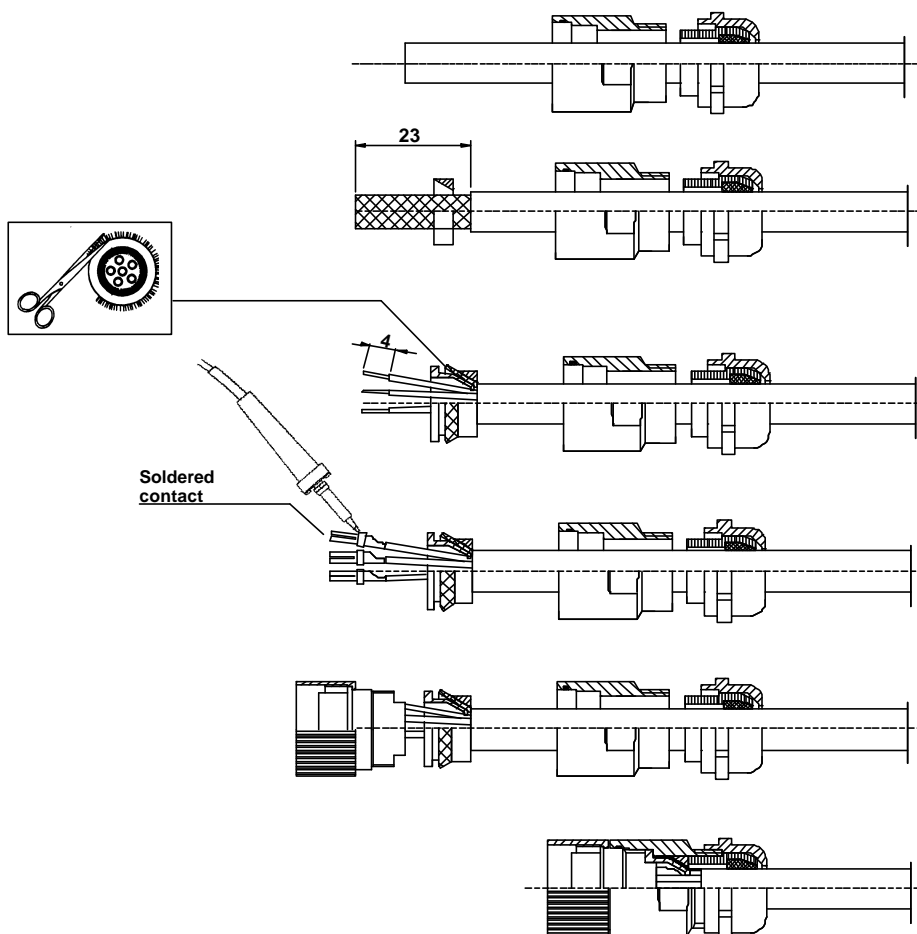

BPH055S - Wiring the drive resolver connector

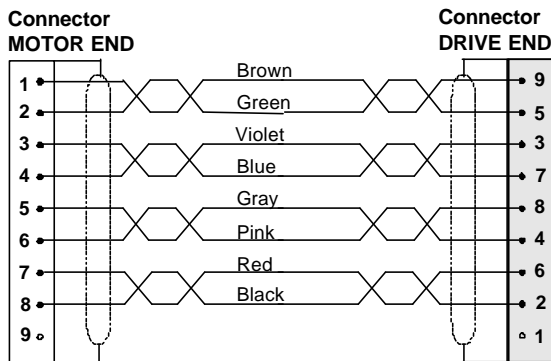

Connections pinout

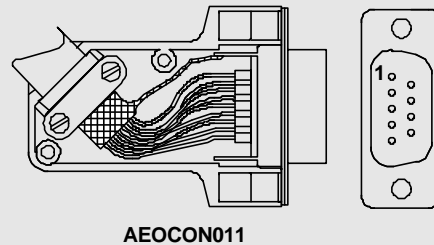

If you constructor your own drive resolver connector with shielding, please do so according to the followig procedure.

STEP	ACTION
1	Carefully remove about 25mm of the outer covering while taking care not to damage the braided shield.
2	Push the exposed braided shield back over the outer covering.
3	Leave the first 12mm of the braided shield free and insulate the rear portion with shrink tubing.
4	Carefully strip about 5mm from the individual wires while taking care not to damage the copper strands.
5	Verify pin assignments then solder the individual wires to the solder cups of the Sub-D connector. (Check the wire colours)
6	Attach the cable to the connector housing strain relief; the strain relief must have good contact with the exposed shielding of the cable. Place the Sub-D connector in the groove of the half-housing, press the two halves together and fix them by screwing.

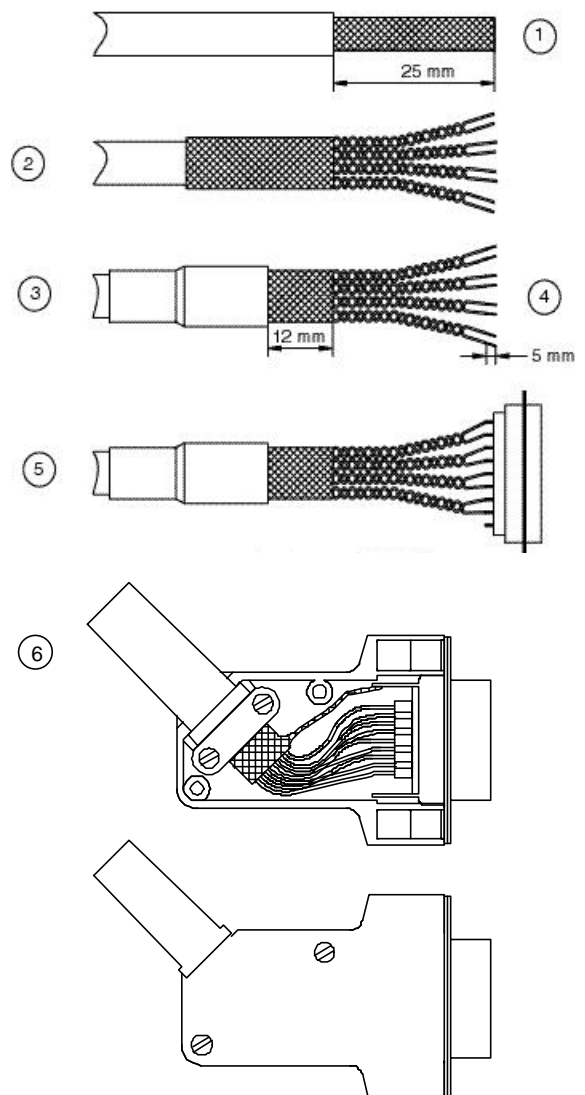

BPH075÷190 - Wiring the motor resolver connector

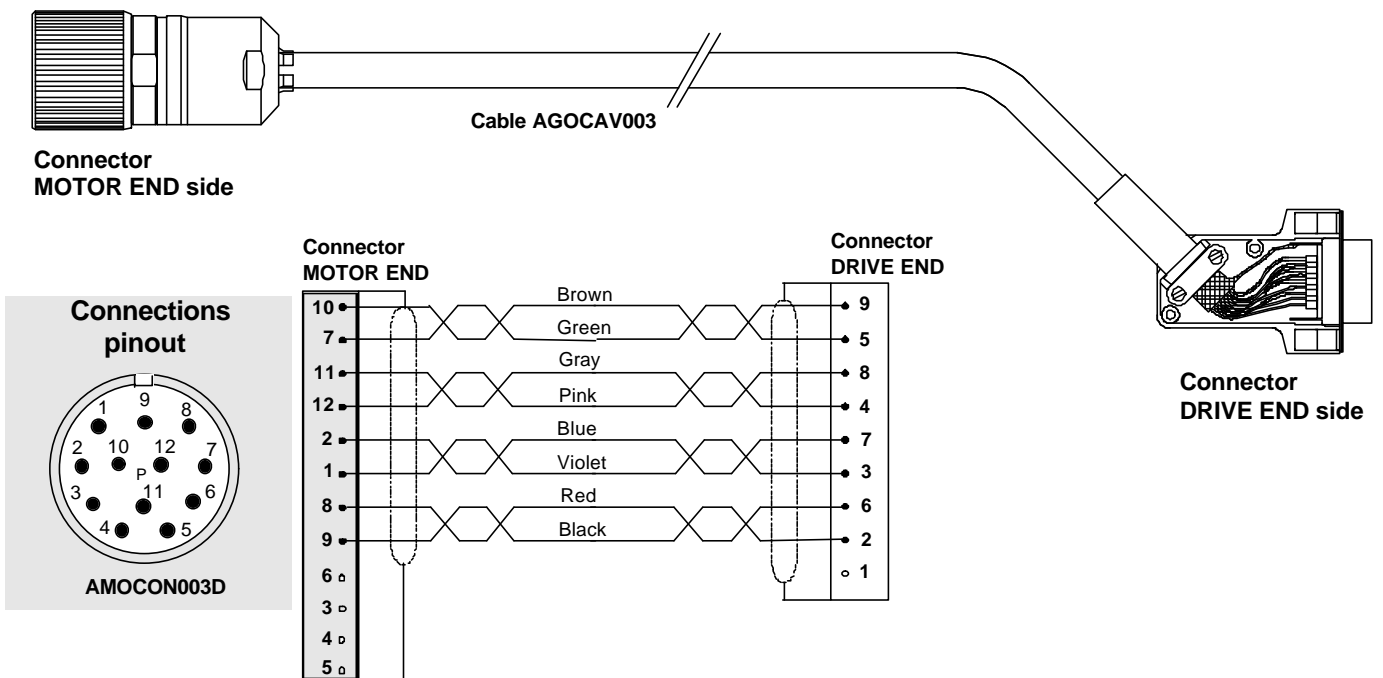

If you constructor your own motor resolver connector with shielding, please do so according to the followig procedure.

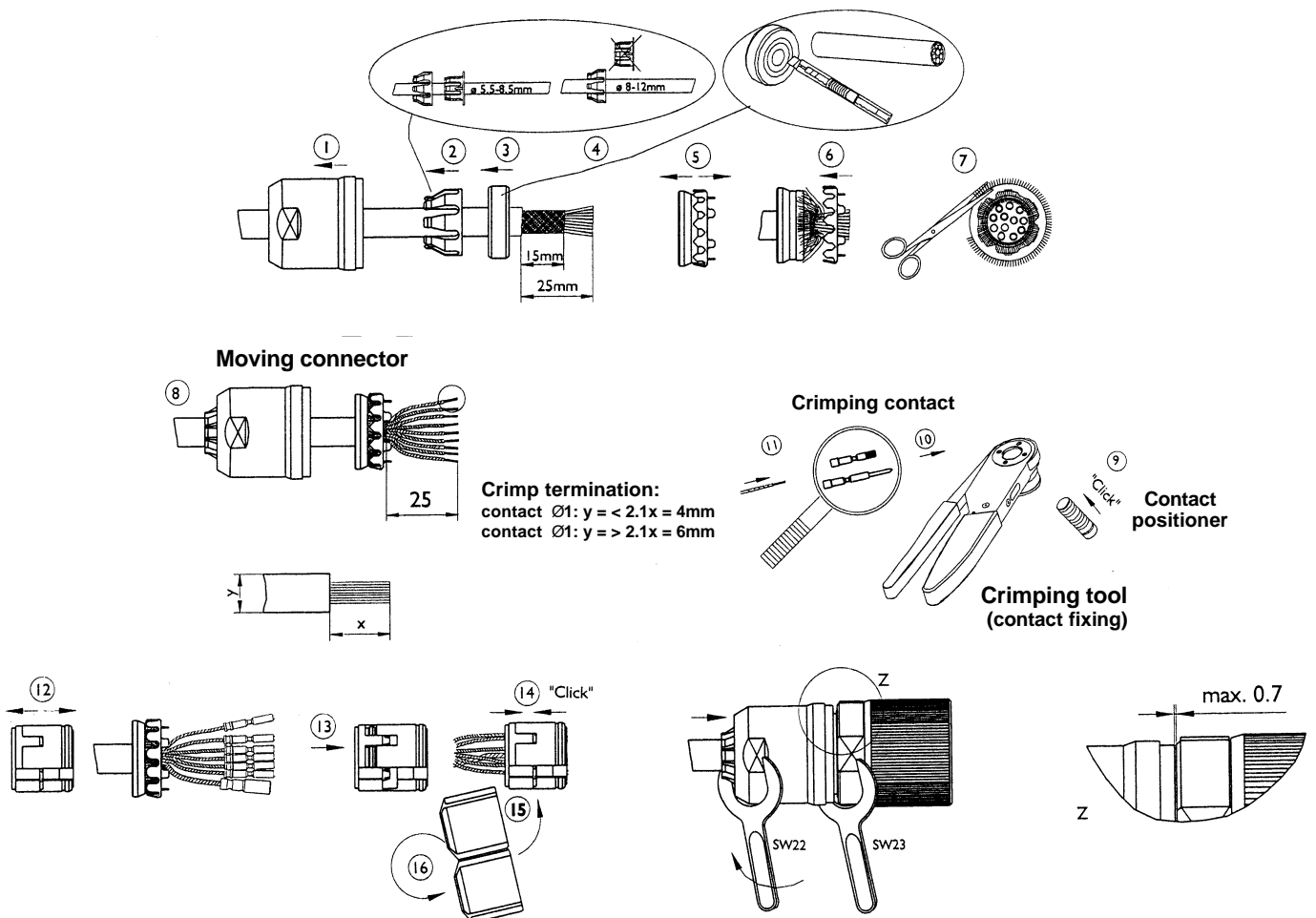

BPH075÷190 - Wiring the drive resolver connector

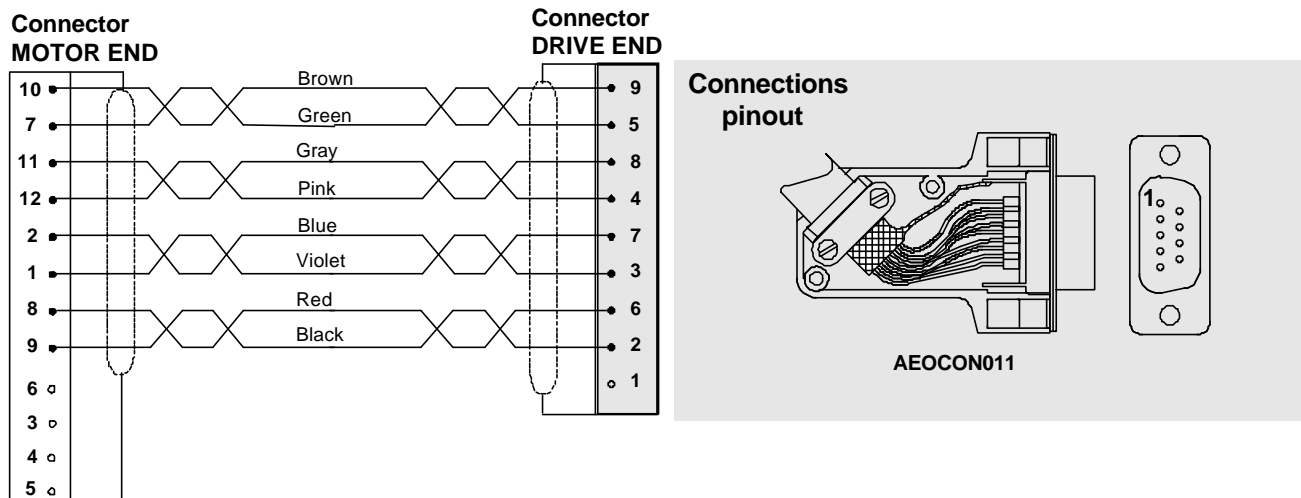

If you constructor your own drive resolver connector with shielding, please do so according to the followig procedure.

STEP	ACTION
1	Carefully remove about 25mm of the outer covering while taking care not to damage the braided shield.
2	Push the exposed braided shield back over the outer covering.
3	Leave the first 12mm of the braided shield free and insulate the rear portion with shrink tubing.
4	Carefully strip about 5mm from the individual wires while taking care not to damage the copper strands.
5	Verify pin assignments then solder the individual wires to the solder cups of the Sub-D connector. (Check the wire colours)
6	Attach the cable to the connector housing strain relief; the strain relief must have good contact with the exposed shielding of the cable. Place the Sub-D connector in the groove of the half-housing, press the two halves together and fix them by screwing.

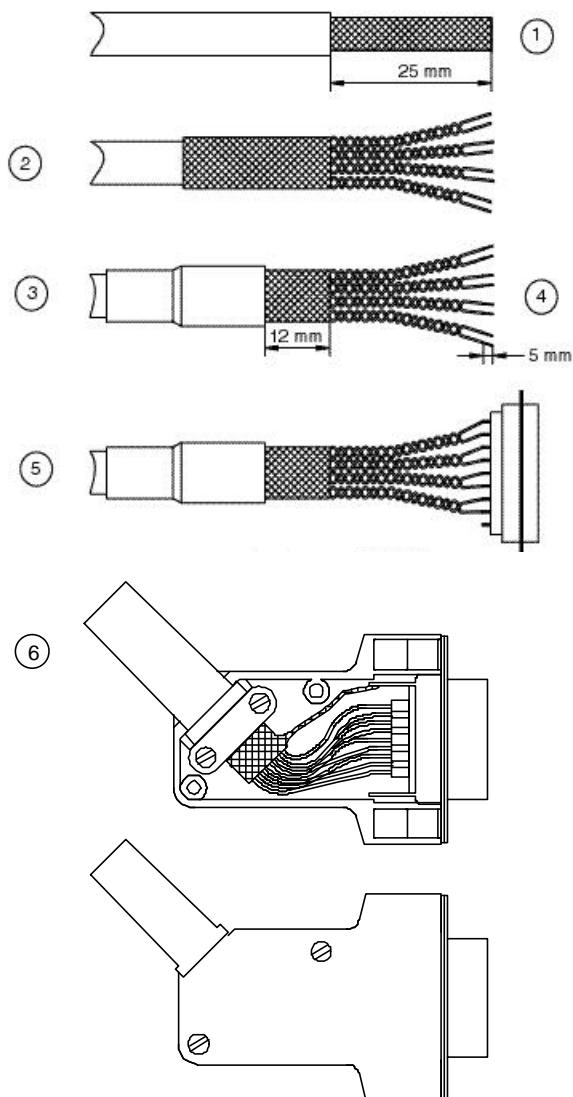

BPH075÷190 - Wiring the motor encoder connector

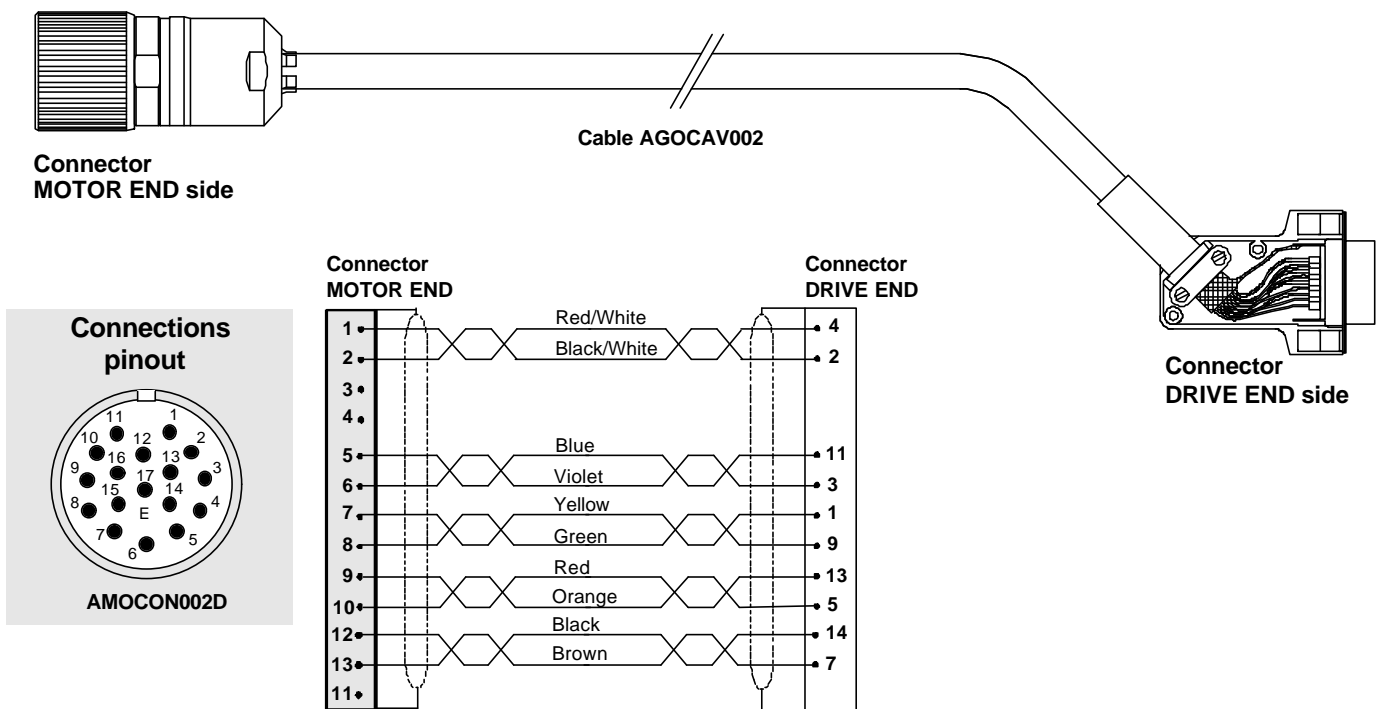

If you constructor your own motor encoder connector with shielding, please do so according to the followiq procedure .

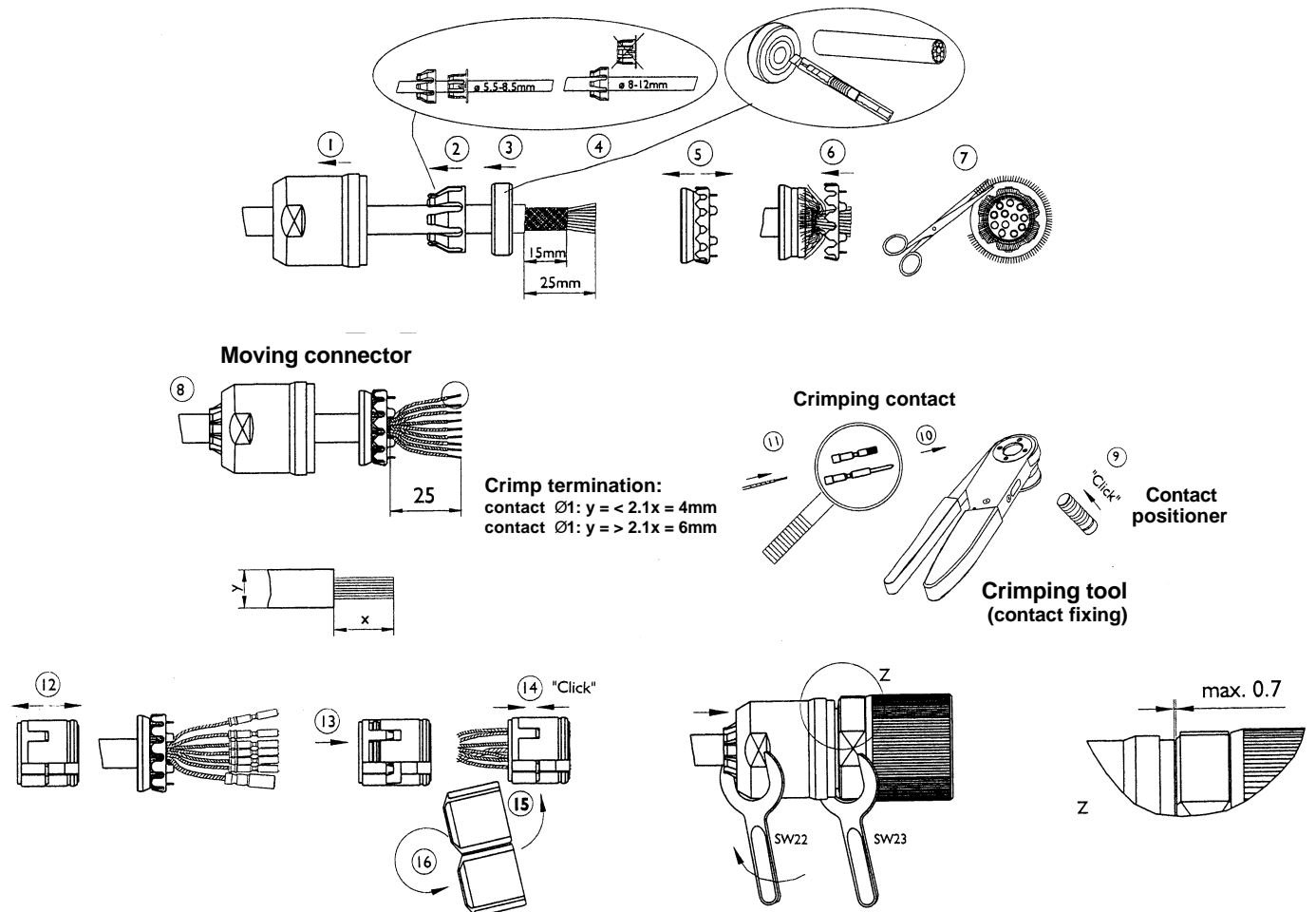

BPH075÷190 - Wiring the drive encoder connector

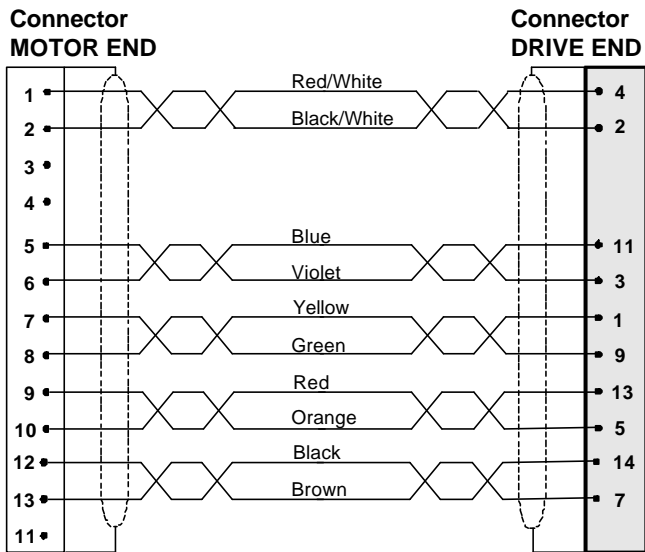

Connections pinout

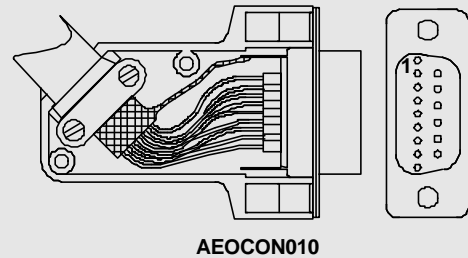

If you constructor your own drive encoder connector with shielding, please do so according to the following procedure.

STEP	ACTION
1	Carefully remove about 25mm of the outer covering while taking care not to damage the braided shield.
2	Push the exposed braided shield back over the outer covering.
3	Leave the first 12mm of the braided shield free and insulate the rear portion with shrink tubing.
4	Carefully strip about 5mm from the individual wires while taking care not to damage the copper strands.
5	Verify pin assignments then solder the individual wires to the solder cups of the Sub-D connector. (Check the wire colours)
6	Attach the cable to the connector housing strain relief; the strain relief must have good contact with the exposed shielding of the cable. Place the Sub-D connector in the groove of the half-housing, press the two halves together and fix them by screwing.

