

# ACCU ELECTRIC MOTORS INC

USA: (888) 932-9183

CANADA: (905) 829-2505

- ✓ Over 100 years cumulative experience
- ✓ 24 hour rush turnaround / technical support service
- ✓ Established in 1993



The leading independent repairer of servo motors and drives in North America.

Visit us on the web:

[www.servo-repair.com](http://www.servo-repair.com)

[www.servorepair.ca](http://www.servorepair.ca)

[www.ferrocontrol.com](http://www.ferrocontrol.com)

[www.sandvikrepair.com](http://www.sandvikrepair.com)

[www.accuelectric.com](http://www.accuelectric.com)

**Scroll down to view your document!**

For 24/7 repair services :

USA: 1 (888) 932 - 9183

Canada: 1 (905) 829 -2505

Emergency After hours: 1 (416) 624 0386

Servicing USA and Canada

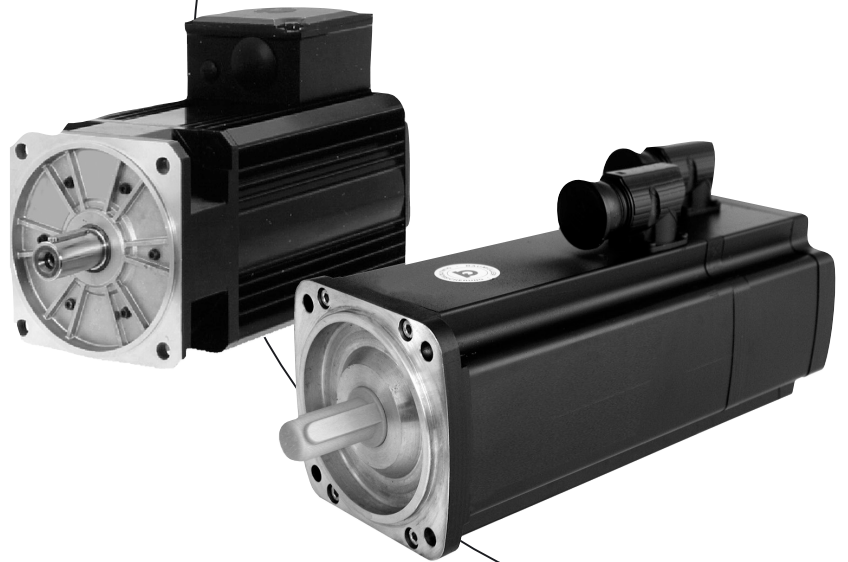

**be in motion be in motion**

**Three-phase  
Synchronous motors**

**DSD 45-100..540 V  
DS 45-100..540 V**



**Table of contents**

**Three-phase synchronous motors DSD 45 - 100..540V ..... 3**

General technical data ..... 3

Explanation of the motor data ..... 4

Type key ..... 4

Technical data ..... 5

    DSD 045..64 U.. (IP 64 without fan)..... 5

    DSD 056..64 U.. (IP 64 without fan)..... 6

    DSD 056..54 O.. (IP 54 with fan)..... 7

    DSD 071..64 U.. (IP 64 without fan)..... 8

    DSD 071..54 O.. (IP 54 with fan)..... 9

    DSD 100..64 U.. (IP 64 without fan)..... 10

    DSD 100..54 O.. (IP 54 with fan)..... 11

Radial force diagrams ..... 12

Brake assignment..... 15

Encoders ..... 16

    Resolver ..... 16

    SINCOS SRS/SRM 50 (Stegmann) ..... 17

Drawings..... 18

    DSD 45 standard version, main connection with connector ..... 18

    DSD 56 / 71 / 100 standard version, main connection with terminal box ..... 19

    DSD 56 / 71 / 100 standard version, main connection with connector ..... 20

    DSD 56 / 71 / 100 standard version with fan, main connection with terminal box..... 21

    DSD 56 / 71 / 100 standard version with fan, main connection with connector ..... 22

Motor cables ..... 23

    Nominal voltage..... 23

    Core lettering ..... 23

    Cable data ..... 23

Main connection cables / Assembled cable with connector..... 25

Encoder cables..... 26

Commissioning and maintenance instructions..... 27

**Three-phase synchronous motors DS 45 - 100..540V ..... 29**

General technical data ..... 29

Ratings definition ..... 30

Winding isolation and temperature rise ..... 30

Explanation of the motor data ..... 30

Basic calculation..... 30

Performance overview..... 31

Type key ..... 31

Technical data ..... 32

    DS standard version..... 32

Radial force diagrams ..... 38

    DS in standard version or with fan ..... 39

    DS in short version..... 42

Main connection – terminal marking and connector assignment..... 44

Thermal sensor..... 45

Fan data ..... 45

Brake assignment..... 46

Encoder ..... 47  
    Resolver ..... 47  
    SINCOS SRS/SRM 50 (Stegmann) ..... 48  
    DS 56 / 71 / 100 standard version, main connection with terminal box..... 49  
    DS 45 / 56 / 71 / 100 standard version, main connection with connector..... 50  
    DS 56 / 71 / 100 standard version with fan, main connection with terminal box ..... 51  
    DS 56 / 71 / 100 standard version with fan, main connection with connector ..... 52  
    DS 56 / 71 / 100 short version, main connection with terminal box..... 53  
    DS 56 / 71 / 100 short version, main connection with connector..... 54  
    Main connection, fan and male and female encoder connectors ..... 55  
Motor cables ..... 57  
    Nominal voltage..... 57  
    Core lettering..... 57  
    Cable data ..... 57  
Main connection cables / Assembled cable with connector..... 59  
Encoder cables..... 60  
Commissioning and maintenance instructions..... 61

Note: Preliminary DSD list!

The technical data—electrical and mechanical—are subject to change!

Date: 05/03

All information in this list represents nonbinding information for customers. The information is subject to continuous development and is continually being updated through our permanent updating service. Please note that data/numbers/information represent current values at the time of printing. This information is not legally binding for measurement, analysis and calculation. Before using any of the information listed in this brochure as the basis of personal calculations and/or applications, please ensure that the information you are using is current.

No liability is assumed that the information presented here is correct

## Three-phase synchronous motors DSD 45 - 100..540V

New design for frame size 56/71/100 available from October 2003.  
Frame size 45 is already available.



### General technical data

Version:	IM B5	Horizontal mounting
	IM V1	Vertical mounting, shaft end to the bottom
	IM V3	Vertical mounting, shaft end to the top
Protection type:	IP65	Surface-cooled, <b>without</b> fan, DIN 40050, DIN 40053
	IP54	Surface-cooled, <b>with</b> fan
Shaft gland:	IP64	Standard
	IP65	with shaft sealing ring (option)
Connection:		
Main connection	U V W	Terminal box Connector (option) Frame size 45 with connector as standard
Control connection		12-pin connector
Brake		in the main connection
Thermal sensor		in control connection (for resolver only)
Cooling type:	IC 0041	Completely enclosed machine surface-cooled no fan
	IC 0641	as above, but with fan (air flow direction from B to A end)
Thermal sensor:		Linear thermal sensor for evaluation in the controller
Temperature rise:	$\Delta\theta = 105K$	Insulation class F acc. to EN 60034
Temperature range:	0...+ 40°C	
Storage:	-30°C...+85°C	
Paint:	black matt	RAL 9005
Bearing:	$\geq 20,000h$	Service life
Balance quality:	N	According to DIN ISO 2373
	R, S	On request
Vibration resistant up to:	radial 3g	20 Hz to 2 kHz acc. to EN 60068-2-6
	axial 0.5g	20 Hz to 2 kHz acc. to EN 60068-2-6 Higher vibration resistance on request
Flange:	acc. to IEC standard	Dimension b1: Tolerance j6
Shaft end:	cylindrical	Smooth acc. to DIN 748; (also available with key DIN 6885) Dimension d: Tolerance k6 Centering with internal thread acc. to DIN 332 form D
Holding brake:	Option	
Actual speed encoder:	2-pin resolver	
	Sincos encoder (option)	Other encoders on request

### Explanation of the motor data

$M_0, I_0$	Nominal torque (Nm) with nominal current (A) with speed $\geq 1 \text{ min}^{-1}$ no time limit, $I_0$ is the r.m.s. value
$M_{0, \max}, I_{0, \max}$	Maximum torque ( Nm ) with Maximum current (A) with zero speed, $I_{0, \max}$ is the r.m.s. value
$P_N$	Nominal power ( kW ) with nominal speed $n_N$ in continuous operation (S1) $T_A=40^\circ\text{C}$ installation up to 1000m a.m.s.l.
$M_N, I_N$	Nominal torque (Nm) at nominal current (A) with nominal speed $n_N$ in continuous operation (S1); $T_A= 40^\circ\text{C}$
$n_N$	Nominal speed ( $\text{min}^{-1}$ )
$k_{TN}$	Torque constant: $M_N / I_N$
$f_N$	Nominal frequency (Hz)
J	Rotor inertia incl. resolver without holding brake (kg cm <sup>2</sup> )
m	Weight in kg

The specified ratings / torques at nominal speed are achieved with a chopping frequency of  $\geq 4 \text{ kHz}$  in the power unit of the converter. A chopping frequency of  $> 6 \text{ kHz}$  is recommended.

### Type key

DSD	G	100	S	64	U	20	-5			
								DC link voltage:	5 X	540 V special
								Nominal speed:	e.g. 20 = X:	2000 $\text{min}^{-1}$ special
								Cooling:	U O W	Without fan With fan Water cooling
								Type of protection:	e.g. 64 =	IP64
								Length:	S M L B	
								Frame size:	045 056 071 100	
								Holding brake:	Without with	G
								Motor type:	DSD	Three-phase Synchronous Dynamic

## Technical data

### DSD 045..64 U.. (IP 64 without fan)

Mains voltage 3 AC 400 V for converters with uncontrolled supply

Nom. speed $n_N$ min <sup>-1</sup>	Motor type	Standstill torque <sup>1)</sup>		Standstill current <sup>1)</sup>		max. standstill torque $M_{O,max}$ Nm	max. standstill current $I_{O,max}$ A	Nom. power <sup>1)</sup> $P_N$ kW	Nom. torque <sup>1)</sup>		Nom. current <sup>1)</sup>	
		$M_O$ Nm	$M_O$ lbf ft	$I_O$ A	$M_N$ Nm				$M_N$ lbf ft	$I_N$ A		
3000	DSD045S64U30-5	2.5	1.84	1.60	11	8	7.6	0.63	0.8	2.0	1.5	1.40
	DSD045M64U30-5	4.0	2.95	2.40	18 <sup>2)</sup>	13	12.0	0.94	1.3	3.0	2.2	2.0
	DSD045L64U30-5	5.2	3.84	3.10	25 <sup>2)</sup>	18	16.2	1.22	1.6	3.9	2.9	2.50
4500	DSD045S64U45-5	2.5	1.84	2.25	11	8	11.0	0.89	1.2	1.9	1.4	1.95
	DSD045M64U45-5	4.0	2.95	3.45	18 <sup>2)</sup>	13	17.0	1.18	1.6	2.5	1.8	2.40
	DSD045L64U45-5	5.2	3.84	4.45	25 <sup>2)</sup>	18	23.0	1.37	1.8	2.9	2.1	2.74

Nom. speed $n_N$ min <sup>-1</sup>	Motor type	Torque constant		Nom. frequency $f_N$ Hz	Rotor inertia (motor)		Weight	
		$k_{TN}$ Nm/A	$k_{TN}$ lbf ft / A		J Kgcm <sup>2</sup>	J lb in <sup>2</sup>	m kg	m lb
3000	DSD045S64U30-5	1.43	1.05	200.0	1.39	0.47	4.2	9.3
	DSD045M64U30-5	1.50	1.11	200.0	1.64	0.56	5.3	11.7
	DSD045L64U30-5	1.56	1.15	200.0	1.90	0.65	6.3	13.9
4500	DSD045S64U45-5	0.97	0.72	300.0	1.39	0.47	4.2	9.3
	DSD045M64U45-5	1.04	0.77	300.0	1.64	0.56	5.3	11.7
	DSD045L64U45-5	1.06	0.78	300.0	1.90	0.65	6.3	13.9

1) Winding overhear  $\Delta T < 105$  K; direct flange connection (mounting plate 250mm×250mm)

2) max. shaft torque:  $M_{max} \leq 16$  Nm for shaft end with key  
 $M_{max} \leq 28$  Nm for shaft end without key

Legend

American units
----------------

**DSD 056..64 U.. (IP 64 without fan)**

Mains voltage 3 AC 400 V for converters with uncontrolled supply

Nom. speed $n_N$ $\text{min}^{-1}$	Motor type	Standstill torque <sup>1)</sup>		Standstill current <sup>1)</sup>		max. standstill torque		max. standstill current		Nom. power <sup>1)</sup>		Nom. torque <sup>1)</sup>		Nom. current <sup>1)</sup>
		$M_0$ Nm	$M_0$ lbf ft	$I_0$ A	$M_{0,max}$ Nm	$M_{0,max}$ lbf ft	$I_{0,max}$ A	$P_N$ KW	$P_N$ hp	$M_N$ Nm	$M_N$ lbf ft	$I_N$ A		
2000	DSD056S64U20-5	5.5	4.06	2.4	23	17	11.0	1.0	1.3	4.8	3.5	2.2		
	DSD056M64U20-5	8.8	6.49	3.8	38	28	18.0	1.6	2.1	7.5	5.5	3.3		
	DSD056L64U20-5	11.5	8.48	4.9	52	38	24.0	2.0	2.7	9.4	6.9	4.2		
3000	DSD056S64U30-5	5.5	4.06	3.5	23	17	16.0	1.3	1.7	4.1	3.0	2.7		
	DSD056M64U30-5	8.8	6.49	5.4	38	28	25.5	2.0	2.7	6.5	4.8	4.2		
	DSD056L64U30-5	11.5	8.48	6.8	52	38	34.0	2.4	3.2	7.7	5.7	5.0		
4500	DSD056S64U45-5	5.5	4.06	4.9	23	17	22.0	1.6	2.1	3.4	2.5	3.3		
	DSD056M64U45-5	8.8	6.49	7.6	38	28	36.0	2.4	3.2	5.0	3.7	4.7		
	DSD056L64U45-5	11.5	8.48	9.6	52	38	47.5	2.3	3.1	4.8	3.5	4.7		

Nom. speed $n_N$ $\text{min}^{-1}$	Motor type	Torque constant		Nom. frequency $f_N$ Hz	Rotor inertia (motor)		Weight	
		$k_{TN}$ Nm/A	$k_{TN}$ lbf ft / A		J Kgcm <sup>2</sup>	J lb in <sup>2</sup>	m Kg	m lb
2000	DSD056S64U20-5	2.18	1.61	133.3	3.0	1.03	8.2	18.1
	DSD056M64U20-5	2.27	1.67	133.3	4.3	1.47	10.0	22.0
	DSD056L64U20-5	2.24	1.65	133.3	5.7	1.95	11.8	26.0
3000	DSD056S64U30-5	1.52	1.12	200.0	3.0	1.03	8.2	18.1
	DSD056M64U30-5	1.55	1.14	200.0	4.3	1.47	10.0	22.0
	DSD056L64U30-5	1.54	1.14	200.0	5.7	1.95	11.8	26.0
4500	DSD056S64U45-5	1.03	0.76	300.0	3.0	1.03	8.2	18.1
	DSD056M64U45-5	1.06	0.78	300.0	4.3	1.47	10.0	22.0
	DSD056L64U45-5	1.02	0.75	300.0	5.7	1.95	11.8	26.0

1) Winding overheat  $\Delta T < 105$  K; direct flange connection (mounting plate 250mmx250mm)

Legend

	American units
--	----------------

**DSD 056..54 O.. (IP 54 with fan)**

Mains voltage 3 AC 400 V for converters with uncontrolled supply

Nom. speed $n_N$ $\text{min}^{-1}$	Motor type	Standstill torque <sup>1)</sup>		Standstill current <sup>1)</sup>		max. standstill torque		Max. standstill current		Nom. power <sup>1)</sup>		Nom. torque <sup>1)</sup>		Nom. current <sup>1)</sup>
		$M_o$ Nm	$M_o$ lbf ft	$I_o$ A	$M_{o,max}$ Nm	$M_{o,max}$ lbf ft	$I_{o,max}$ A	$P_N$ KW	$P_N$ hp	$M_N$ Nm	$M_N$ lbf ft	$I_N$ A		
2000	DSD056S54O20-5	7.2	5.31	3.2	23	17	11.0	1.4	1.9	6.6	4.9	3.0		
	DSD056M54O20-5	11.8	8.7	5.1	38	28	18.0	2.3	3.1	11.0	8.1	4.9		
	DSD056L54O20-5	15.5	11.4	6.7	52	38	24.0	3.0	4.0	14.2	10.5	6.3		
3000	DSD056S54O30-5	7.2	5.31	4.6	23	17	16.0	2.0	2.7	6.3	4.6	4.1		
	DSD056M54O30-5	11.8	8.7	7.3	38	28	25.5	3.3	4.4	10.4	7.7	6.6		
	DSD056L54O30-5	15.5	11.4	9.4	52	38	34.0	4.1	5.5	13.0	9.6	8.2		
4500	DSD056S54O45-5	7.2	5.31	6.4	23	17	22.0	2.6	3.5	5.5	4.1	5.2		
	DSD056M54O45-5	11.8	8.7	10.3	38	28	36.0	4.2	5.6	9.0	6.6	8.2		
	DSD056L54O45-5	15.5	11.4	13.0	52	38	47.5	5.4	7.2	11.4	8.4	10.5		

Nom. speed $n_N$ $\text{min}^{-1}$	Motor type	Torque constant		Nom. frequency $f_N$ Hz	Rotor inertia (motor) J Kgcm <sup>2</sup>	Weight		
		$k_{TN}$ Nm/A	$k_{TN}$ lbf ft / A			J lb in <sup>2</sup>	m Kg	m lb
2000	DSD056S54O20-5	2.20	1.62	133.3	3.0	1.03	11.0	24.3
	DSD056M54O20-5	2.24	1.65	133.3	4.3	1.47	12.8	28.2
	DSD056L54O20-5	2.25	1.66	133.3	5.7	1.95	14.6	32.2
3000	DSD056S54O30-5	1.54	1.14	200.0	3.0	1.03	11.0	24.3
	DSD056M54O30-5	1.58	1.17	200.0	4.3	1.47	12.8	28.2
	DSD056L54O30-5	1.58	1.17	200.0	5.7	1.95	14.6	32.2
4500	DSD056S54O45-5	1.06	0.78	300.0	3.0	1.03	11.0	24.3
	DSD056M54O45-5	1.10	0.81	300.0	4.3	1.47	12.8	28.2
	DSD056L54O45-5	1.09	0.80	300.0	5.7	1.95	14.6	32.2

1) Winding overheat  $\Delta T < 105$  K; direct flange connection (mounting plate 250mmx250mm)

Legend

	American units
--	----------------

**DSD 071..64 U.. (IP 64 without fan)**

Mains voltage 3 AC 400 V for converters with uncontrolled supply

Nom. speed $n_N$ $\text{min}^{-1}$	Motor type	Standstill torque <sup>1)</sup>		Standstill current <sup>1)</sup>	Max. standstill torque	max. standstill current	Nom. power <sup>1)</sup>		Nom. torque <sup>1)</sup>		Nom. current <sup>1)</sup>	
		$M_O$ Nm	$M_O$ lbf ft	$I_O$ A	$M_{O,max}$ Nm	$I_{O,max}$ A	$P_N$ KW	$P_N$ hp	$M_N$ Nm	$M_N$ lbf ft	$I_N$ A	$I_N$ A
2000	DSD071S64U20-5	13.5	9.96	5.7	51	38	24.5	2.3	3.1	11.0	8.1	4.9
	DSD071M64U20-5	19.5	14.4	8.4	75	55	36.5	3.1	4.2	15.0	11.1	6.8
	DSD071L64U20-5	25.0	18.4	10.7	100	74	48.0	4.2	5.6	20.0	14.8	8.9
3000	DSD071S64U30-5	13.5	9.96	8.2	51	38	35.5	2.9	3.9	9.2	6.8	6.0
	DSD071M64U30-5	19.5	14.4	11.7	75	55	51.0	4.0	5.4	12.6	9.3	8.0
	DSD071L64U30-5	25.0	18.4	15.2	100	74	68.0	5.0	6.7	16.0	11.8	10.2
4500	DSD071S64U45-5	13.5	9.96	11.6	51	38	50.0	3.4	4.6	7.2	5.3	6.7
	DSD071M64U45-5	19.5	14.4	17.0	75	55	75.0	4.3	5.8	9.2	6.8	8.7
	DSD071L64U45-5	25.0	18.4	21.4	100	74	95.0	5.2	7.0	11.0	8.1	10.0

Nom. speed $n_N$ $\text{min}^{-1}$	Motor type	Torque constant		Nom. frequency $f_N$ Hz	Rotor inertia (motor) J kgcm <sup>2</sup>	Weight		
		$k_{TN}$ Nm/A	$k_{TN}$ lbf ft / A			J lb in <sup>2</sup>	m kg	m lb
2000	DSD071S64U20-5	2.24	1.65	133.3	9.2	3.14	16.2	35.7
	DSD071M64U20-5	2.21	1.63	133.3	12.8	4.37	18.7	41.2
	DSD071L64U20-5	2.25	1.66	133.3	16.5	5.64	21.0	46.3
3000	DSD071S64U30-5	1.53	1.13	200.0	9.2	3.14	16.2	35.7
	DSD071M64U30-5	1.58	1.17	200.0	12.8	4.37	18.7	41.2
	DSD071L64U30-5	1.57	1.16	200.0	16.5	5.64	21.0	46.3
4500	DSD071S64U45-5	1.07	0.79	300.0	9.2	3.14	16.2	35.7
	DSD071M64U45-5	1.06	0.78	300.0	12.8	4.37	18.7	41.2
	DSD071L64U45-5	1.10	0.81	300.0	16.5	5.64	21.0	46.3

1) Winding overheat  $\Delta T < 105$  K; direct flange connection (mounting plate 400mm×400mm)

Legend

American units
----------------

**DSD 071..54 O.. (IP 54 with fan)**

Mains voltage 3 AC 400 V for converters with uncontrolled supply

Nom. speed $n_N$ $\text{min}^{-1}$	Motor type	Standstill torque <sup>1)</sup>		Standstill current <sup>1)</sup>		Max. standstill torque		max. standstill current		Nom. power <sup>1)</sup>		Nom. torque <sup>1)</sup>		Nom. current <sup>1)</sup>	
		$M_0$ Nm	$M_0$ lbf ft	$I_0$ A	$M_{0,max}$ Nm	$M_{0,max}$ lbf ft	$I_{0,max}$ A	$P_N$ kW	$P_N$ hp	$M_N$ Nm	$M_N$ lbf ft	$I_N$ A			
2000	DSD071S54O20-5	18.0	13.3	7.7	51	38	24.5	3.1	4.2	15.0	11.1	6.7			
	DSD071M54O20-5	26.5	19.5	11.3	75	55	36.5	4.6	6.2	22.0	16.2	9.9			
	DSD071L54O20-5	34.5	25.4	14.8	100	74	48.0	6.1	8.2	29.0	21.4	12.8			
3000	DSD071S54O30-5	18.0	13.3	11.2	51	38	35.5	4.2	5.6	13.5	10.0	8.8			
	DSD071M54O30-5	26.5	19.5	15.9	75	55	51.0	6.3	8.4	20.0	14.8	12.6			
	DSD071L54O30-5	34.5	25.4	21.0	100	74	68.0	8.0	10.7	24.5	18.1	15.4			
4500	DSD071S54O45-5	18.0	13.3	15.7	51	38	50.0	5.7	7.6	12.0	8.9	11.0			
	DSD071M54O45-5	26.5	19.5	23.0	75	55	75.0	8.0	10.7	17.0	12.5	15.8			
	DSD071L54O45-5	34.5	25.4	29.6	100	74	95.0	10.1	13.5	21.5	15.9	19.2			

Nom. speed $n_N$ $\text{min}^{-1}$	Motor type	Torque constant		Nom. frequency $f_N$ Hz	Rotor inertia (motor) J Kgcm <sup>2</sup>	Weight		
		$k_{TN}$ Nm/A	$k_{TN}$ lbf ft / A			J lb in <sup>2</sup>	m Kg	m lb
2000	DSD071S54O20-5	2.24	1.65	133.3	9.2	3.14	20.0	44.1
	DSD071M54O20-5	2.22	1.64	133.3	12.8	4.37	22.5	49.6
	DSD071L54O20-5	2.26	1.67	133.3	16.5	5.64	24.8	54.7
3000	DSD071S54O30-5	1.53	1.13	200.0	9.2	3.14	20.0	44.1
	DSD071M54O30-5	1.59	1.17	200.0	12.8	4.37	22.5	49.6
	DSD071L54O30-5	1.59	1.17	200.0	16.5	5.64	24.8	54.7
4500	DSD071S54O45-5	1.09	0.80	300.0	9.2	3.14	20.0	44.1
	DSD071M54O45-5	1.08	0.80	300.0	12.8	4.37	22.5	49.6
	DSD071L54O45-5	1.12	0.83	300.0	16.5	5.64	24.8	54.7

1) Winding overheat  $\Delta T < 105$  K; direct flange connection (mounting plate 400mmx400mm)

Legend

	American units
--	----------------

**DSD 100..64 U.. (IP 64 without fan)**

Mains voltage 3 AC 400 V for converters with uncontrolled supply

Nom. speed $n_N$ $\text{min}^{-1}$	Motor type	Standstill torque <sup>1)</sup>	Standstill current <sup>1)</sup>		max. standstill torque		max. standstill current		Nom. power <sup>1)</sup>		Nom. torque <sup>1)</sup>		Nom. current <sup>1)</sup>
		$M_0$ Nm	$M_0$ lbf ft	$I_0$ A	$M_{0,max}$ Nm	$M_{0,max}$ lbf ft	$I_{0,max}$ A	$P_N$ KW	$P_N$ hp	$M_N$ Nm	$M_N$ lbf ft	$I_N$ A	
1200	DSD100S64U12-5	34.0	25.1	9.1	105	77	33	3.8	5.1	30.0	22.1	8.3	
	DSD100M64U12-5	51.0	37.6	13.7	158	117	49	5.6	7.5	44.5	32.8	12.3	
	DSD100L64U12-5	66.5	49	18.0	210	155	66	7.0	9.4	56.0	41.3	15.5	
2000	DSD100S64U20-5	34.0	25.1	14.5	105	77	52	5.4	7.2	26.0	19.2	11.5	
	DSD100M64U20-5	51.0	37.6	21.0	158	117	75	7.7	10.3	37.0	27.3	16.0	
	DSD100L64U20-5	66.5	49	27.5	210	155	102	9.4	12.6	45.0	33.2	19.5	
3000	DSD100S64U30-5	34.0	25.1	21.5	105	77	76	6.6	8.9	21.0	15.5	13.5	
	DSD100M64U30-5	51.0	37.6	30.5	158	117	110	9.0	12.1	28.5	21.0	18.5	
	DSD100L64U30-5	66.5	49	40.0	210	155	147	10.7	14.3	34.0	25.1	21.5	
4500	DSD100S64U45-5	34.0	25.1	30.5	105	77	110	5.9	7.9	12.5	9.2	11.7	
	DSD100M64U45-5	51.0	37.6	44.0	158	117	157	7.5	10.1	16.0	11.8	15.0	

Nom. speed $n_N$ $\text{min}^{-1}$	Motor type	Torque constant	Nom. frequency		Rotor inertia (motor)		Weight	
		$k_{TN}$ Nm/A	$k_{TN}$ lbf ft / A	$f_N$ Hz	$J$ Kgcm <sup>2</sup>	$J$ lb in <sup>2</sup>	$m$ kg	$m$ lb
1200	DSD100S64U12-5	3.61	2.66	80.0	42.5	14.52	31.0	68.3
	DSD100M64U12-5	3.62	2.67	80.0	60.0	20.50	38.5	84.9
	DSD100L64U12-5	3.61	2.66	80.0	77.0	26.31	45.5	100.3
2000	DSD100S64U20-5	2.26	1.67	133.3	42.5	14.52	31.0	68.3
	DSD100M64U20-5	2.31	1.70	133.3	60.0	20.50	38.5	84.9
	DSD100L64U20-5	2.31	1.70	133.3	77.0	26.31	45.5	100.3
3000	DSD100S64U30-5	1.56	1.15	200.0	42.5	14.52	31.0	68.3
	DSD100M64U30-5	1.54	1.14	200.0	60.0	20.50	38.5	84.9
	DSD100L64U30-5	1.58	1.17	200.0	77.0	26.31	45.5	100.3
4500	DSD100S64U45-5	1.07	0.79	300.0	42.5	14.52	31.0	68.3
	DSD100M64U45-5	1.07	0.79	300.0	60.0	20.50	38.5	84.9

1) Winding overheat  $\Delta T < 105$  K; direct flange connection (mounting plate 400mm×400mm)

Legend

American units
----------------

**DSD 100..54 O.. (IP 54 with fan)**

Mains voltage 3 AC 400 V for converters with uncontrolled supply

Nom. speed $n_N$ min <sup>-1</sup>	Motor type	Standstill torque <sup>1)</sup>		Standstill current <sup>1)</sup>		Max. standstill torque		max. standstill current		Nom. power <sup>1)</sup>		Nom. torque <sup>1)</sup>		Nom. current <sup>1)</sup>
		M <sub>0</sub> Nm	M <sub>0</sub> lbf ft	I <sub>0</sub> A	M <sub>0,max</sub> Nm	M <sub>0,max</sub> lbf ft	I <sub>0,max</sub> A	P <sub>N</sub> KW	P <sub>N</sub> hp	M <sub>N</sub> Nm	M <sub>N</sub> lbf ft	I <sub>N</sub> A		
1200	DSD100S54O12-5	43.5	32.1	11.8	105	77	33	4.6	6.2	37.0	27.3	10.2		
	DSD100M54O12-5	67.0	49.4	18.0	158	117	49	7.3	9.8	58.0	42.8	16.1		
	DSD100L54O12-5	89.0	65.6	24.0	210	155	66	9.3	12.5	74.0	54.6	20.6		
2000	DSD100S54O20-5	43.5	32.1	18.5	105	77	52	6.8	9.1	32.5	24.0	14.3		
	DSD100M54O20-5	67.0	49.4	27.5	158	117	75	10.3	13.8	49.0	36.1	21.2		
	DSD100L54O20-5	89.0	65.6	37.0	210	155	102	13.4	18.0	64.0	47.2	27.7		
3000	DSD100S54O30-5	43.5	32.1	27.2	105	77	76	8.6	11.5	27.5	20.3	18.0		
	DSD100M54O30-5	67.0	49.4	40.0	158	117	110	13.2	17.7	42.0	31.0	26.8		
	DSD100L54O30-5	89.0	65.6	53.5	210	155	147	17.0	22.8	54.0	39.8	34.0		
4500	DSD100S54O45-5	43.5	32.1	39.0	105	77	110	10.0	13.4	21.5	15.9	20.0		
	DSD100M54O45-5	67.0	49.4	57.5	158	117	157	15.0	20.1	32.0	23.6	29.5		

Nom. speed $n_N$ min <sup>-1</sup>	Motor type	Torque constant		Nom. frequency f <sub>N</sub> Hz	Rotor inertia (motor)		Weight	
		k <sub>TN</sub> Nm/A	k <sub>TN</sub> lbf ft / A		J Kgcm <sup>2</sup>	J lb in <sup>2</sup>	m kg	m lb
1200	DSD100S54O12-5	3.63	2.68	80.0	42.5	14.52	36.3	80.0
	DSD100M54O12-5	3.60	2.66	80.0	60.0	20.50	43.8	96.6
	DSD100L54O12-5	3.59	2.65	80.0	77.0	26.31	50.8	112.0
2000	DSD100S54O20-5	2.25	1.66	133.3	42.5	14.52	36.3	80.0
	DSD100M54O20-5	2.31	1.70	133.3	60.0	20.50	43.8	96.6
	DSD100L54O20-5	2.38	1.76	133.3	77.0	26.31	50.8	112.0
3000	DSD100S54O30-5	1.53	1.13	200.0	42.5	14.52	36.3	80.0
	DSD100M54O30-5	1.56	1.15	200.0	60.0	20.50	43.8	96.6
	DSD100L54O30-5	1.59	1.17	200.0	77.0	26.31	50.8	112.0
4500	DSD100S54O45-5	1.07	0.79	300.0	42.5	14.52	36.3	80.0
	DSD100M54O45-5	1.08	0.80	300.0	60.0	20.50	43.8	96.6

1) Winding overheat ΔT < 105 K; direct flange connection (mounting plate 400mm×400mm)

Legend

	American units
--	----------------

## Radial force diagrams

### Permissible radial forces $F_R$ at the shaft end

All bearings are dimensioned for a service life of approx. 20,000 operating hours; the loads specified in the following must not be exceeded. The specified permissible radial forces  $F_R$  are valid only for horizontal mounting of the motor without additional axial forces.

### Axial load of the motor shaft

When mounting clutches, pulleys, etc. onto the motor shaft, axial forces must not occur! Therefore use the internal thread of the shaft end as assembly aid.

### Example

Force acting on the end of the shaft end (for force acting on the middle of the shaft end  $F_r \times 1.1$ )  
 Bearing life 20,000 h; shaft end with keyway

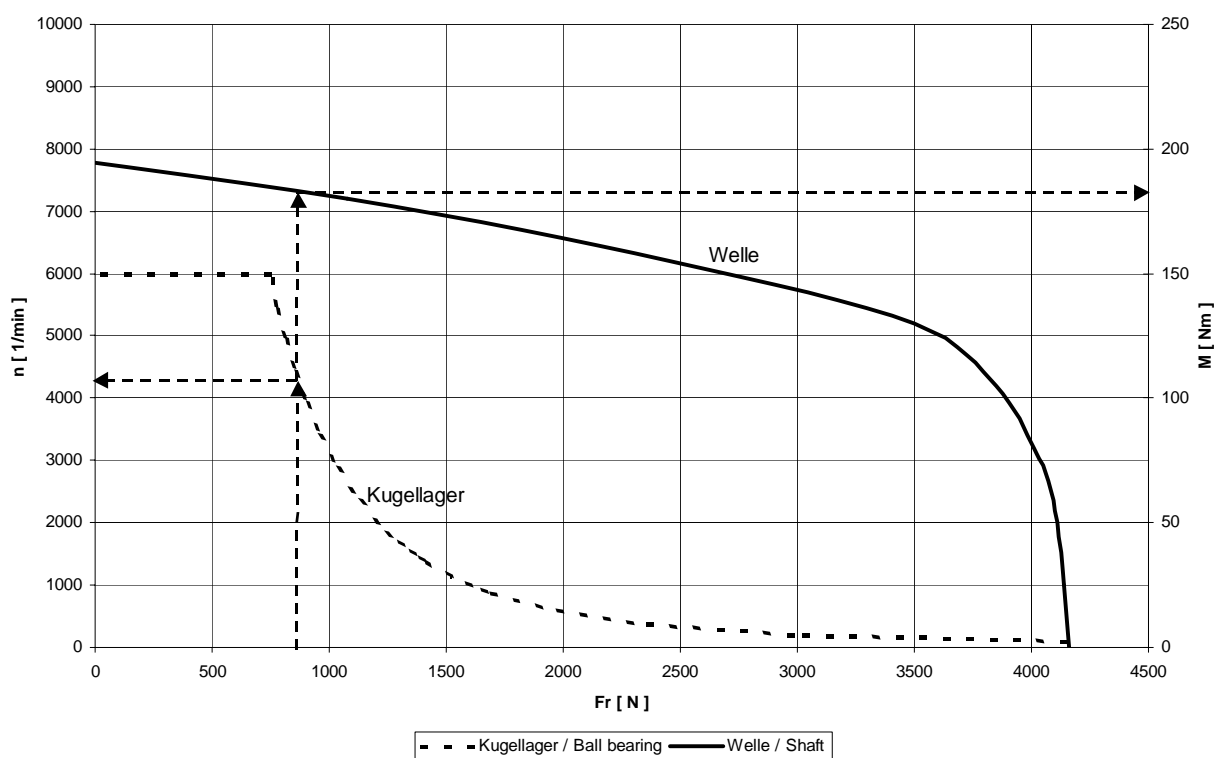

### Explanation of the example

The radial force  $F_r$  of the application is used to determine the possible maximum speed of the bearing in the "Ball bearing" characteristic.

Radial force 850 N  $\Rightarrow$  maximum speed 4250  $\text{min}^{-1}$

The maximum transmittable torque results from the "Shaft" characteristic.

Radial force 850 N  $\Rightarrow$  maximum transmittable torque 185 Nm

DSD 45

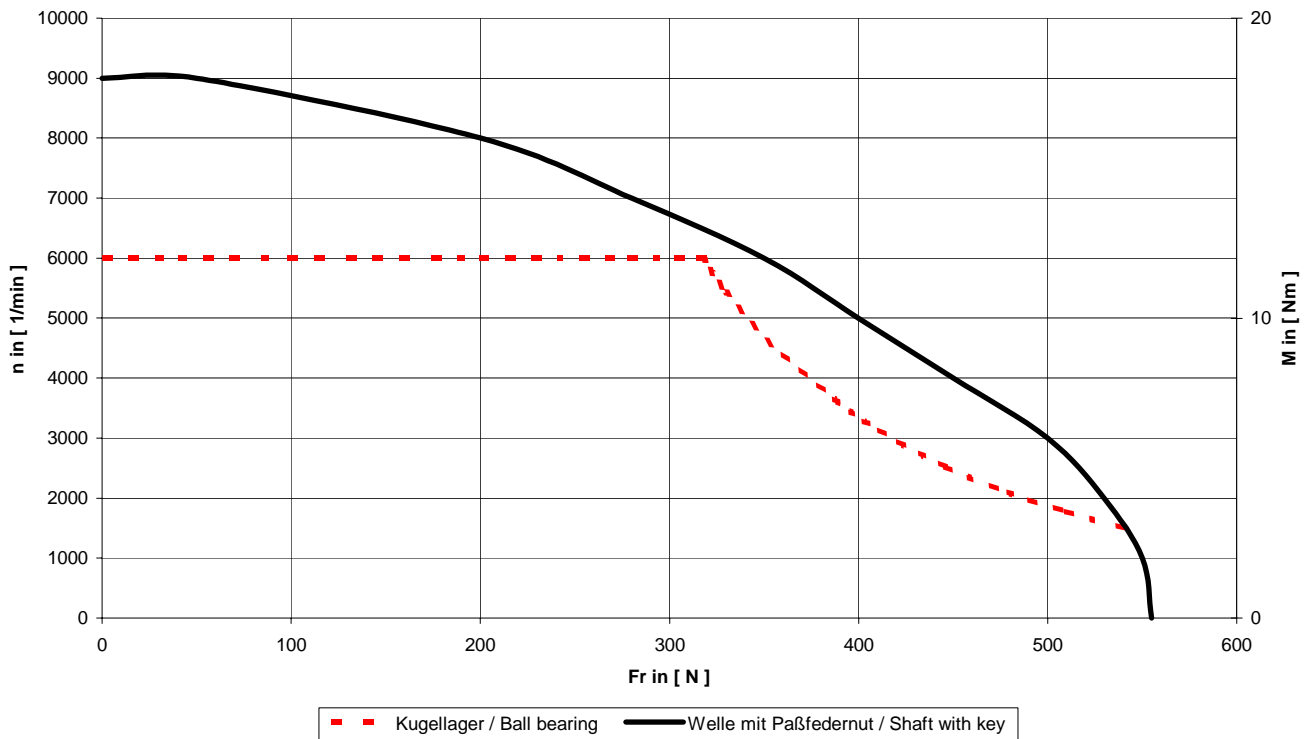

DSD 56

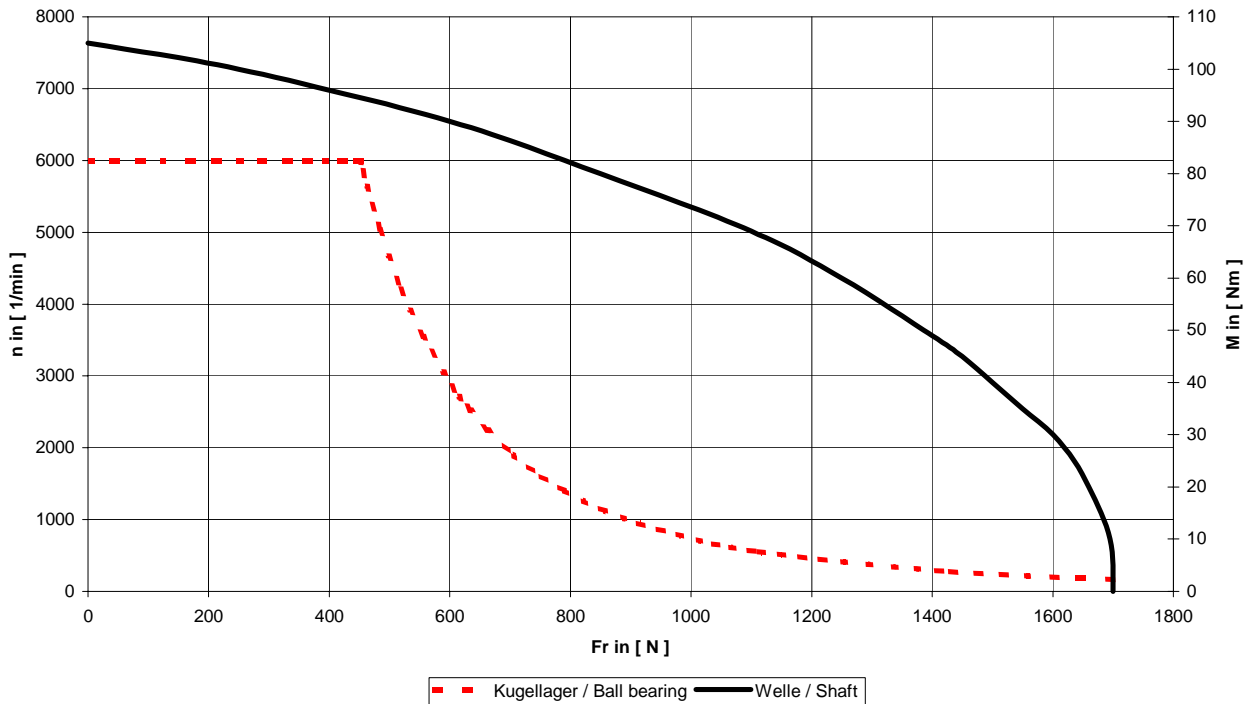

DSD 71

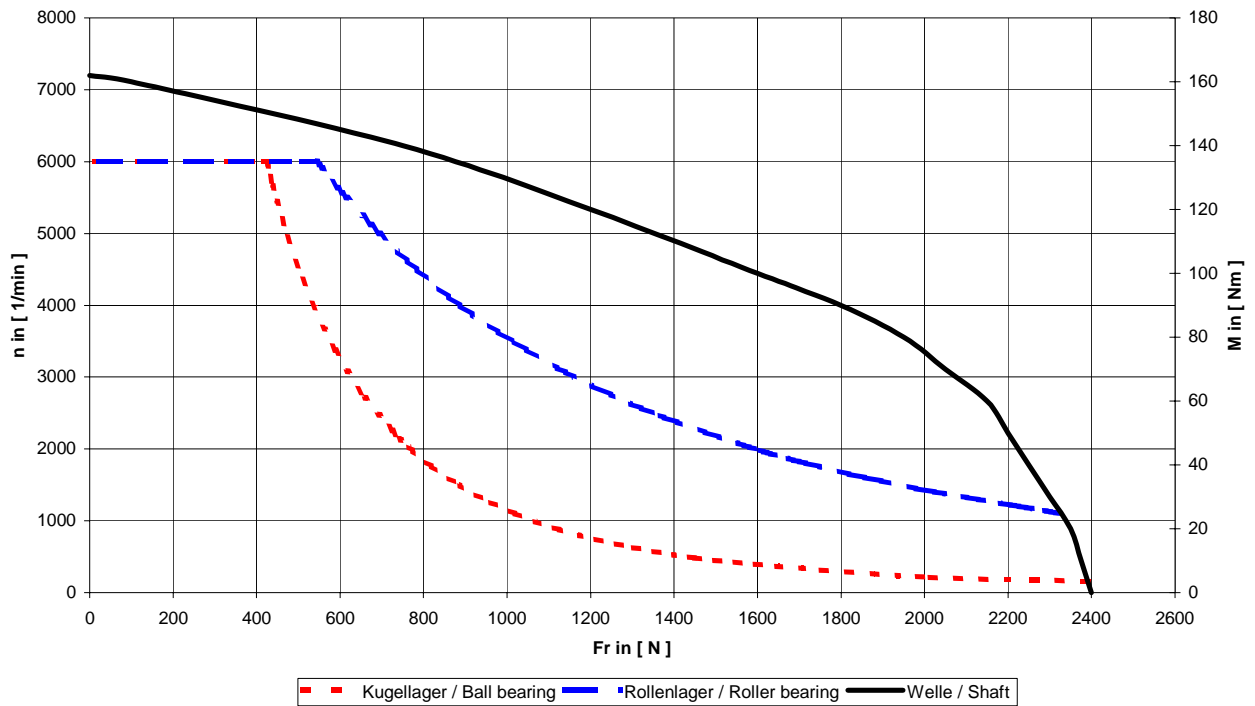

DSD 100

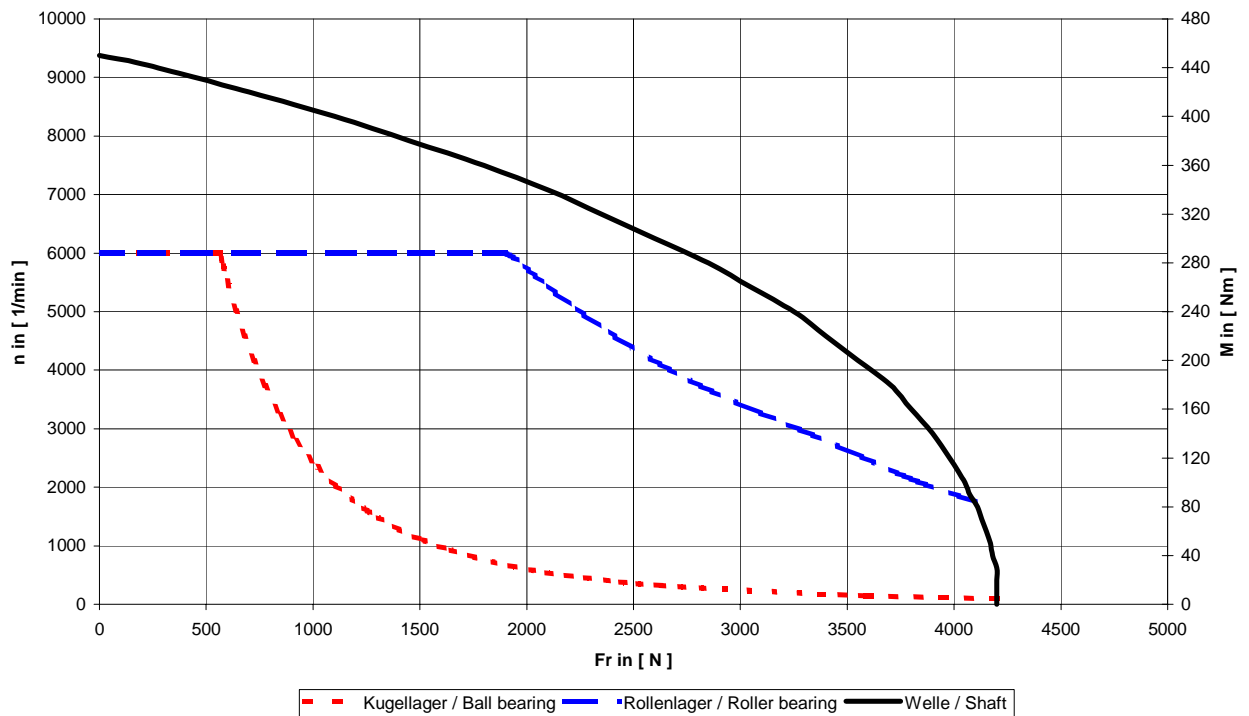

## Brake assignment

The motors are optionally equipped with a holding brake. The brake uses the normally-on principle, i.e. the brake engages with the operating voltage is switched off or fails. The brakes are supplied for a switching voltage of 24 VDC  $\pm$  10%.

The motors are available with the following holding brakes:

Motor type	DSD 45	DSD 56	DSD 71	DSD 100
minimum holding torque	6	15	35	80
max. perm. friction work per braking operation [J]	1000	2000	5000	15000
Connection values ( $\pm$ 10% smoothed)	24 V = 19 W	24 V = 22 W	24 V = 35 W	24 V = 52 W
Inertia [kgcm <sup>2</sup> ]	0.3	0.8	3.5	8.6
Maximum speed [min <sup>-1</sup> ]	6000	6000	6000	4500
Switching time On Brake released [ms]	50	70	100	140
Off [ms]	50	70	100	140
Weight [kg]	1.0	2.0	3.5	8.2

None of the brakes are **fail-safe brakes** so that the torque may be reduced by interference factors beyond control. In accordance with the case of application, observe the relevant accident prevention guidelines as well as the basic safety and health requirements of Appendix I of the Machinery Directive and the harmonized European Standards. In the event of emergency stop or voltage failure, approx. 2,500 braking operations can be carried out without causing the holding brake to overheat (Condition: maximum external inertia = motor inertia and  $n_{max}$ . type-related).

## Encoders

### Resolver

Pole pair number	1
Ratio	0.5
Frequency	5 kHz
Nominal input voltage	4 V
Active input power for no-load operation	112 mW
Current consumption for no-load operation	40 mA
Max. output voltage for no-load operation	2 V eff
Voltage constant	-
Rotor resistance	$44 \Omega \pm 10\%$
Stator resistance	$28 \Omega \pm 10\%$
Rotor impedance for no-load operation	$70 + j 74 \Omega \pm 15\%$
Rotor impedance at short-circuit	$62 + j 66 \Omega \pm 15\%$
Stator impedance for no-load operation with min. coupling	$108 + j 206 \Omega \pm 15\%$
Stator impedance at short-circuit and maximum coupling	$97 + j 183 \Omega \pm 15\%$
Phase shift	$8^\circ$
Zero voltage	$15 \text{ mV} / ^\circ$
Phase error referred to zero position	$10'$

### Resolver connection

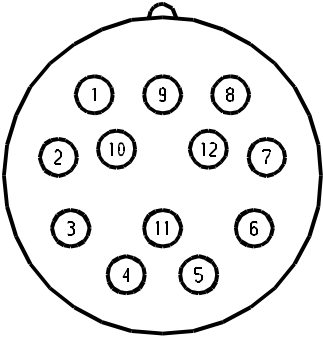
		Pin	Signal
		1	cos -
		2	
		3	
		4	
		5	sin -
		6	sin +
		7	TM -
		8	cos +
		9	TM +
		10	Ref +
		11	
		12	Ref -

View to contact side of female connector

**SINCOS SRS/SRM 50 (Stegmann)**

	SRS 50 / SRM 50	
Number of sine, cosine periods per revolution	1024	
Number of increments per revolution	32768	
Number of absolute resolved revolutions	1	4096
Code type for the absolute value	binary	
Output frequency of sine, cosine signals (kHz)	0 ... 200	
Error limits when evaluating 1024 signals, integral non-linearity (arc seconds)	+/- 45	
Non-linearity within a sine, cosine period; differential non-linearity (arc seconds)	+/- 7	
Working speed up to which the absolute position can be formed (1/min)	6000	
Maximum operating speed (1/min)	12000	
Output signals; 2 x 90° shifted sinusoidal signals ( $V_{pp}$ )	1	
Output signal	Serial RS 485, asynchronous, halbduplex	
Operating voltage range (V)	7 ... 12	
Operating current without load (mA)	80	

**SRS/SRM 50 connection**

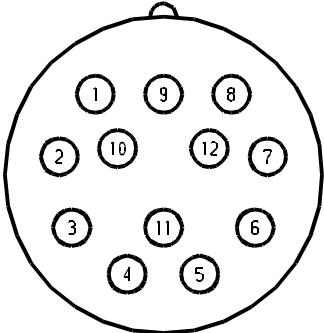
	Pin	Signal
	1	ref cos
	2	+ 485
	3	-
	4	-
	5	sin
	6	ref sin
	7	- 485
	8	cos
	9	-
	10	Gnd
	11	-
	12	+ U

View to contact side of female connector

## Drawings

### DSD 45 standard version, main connection with connector

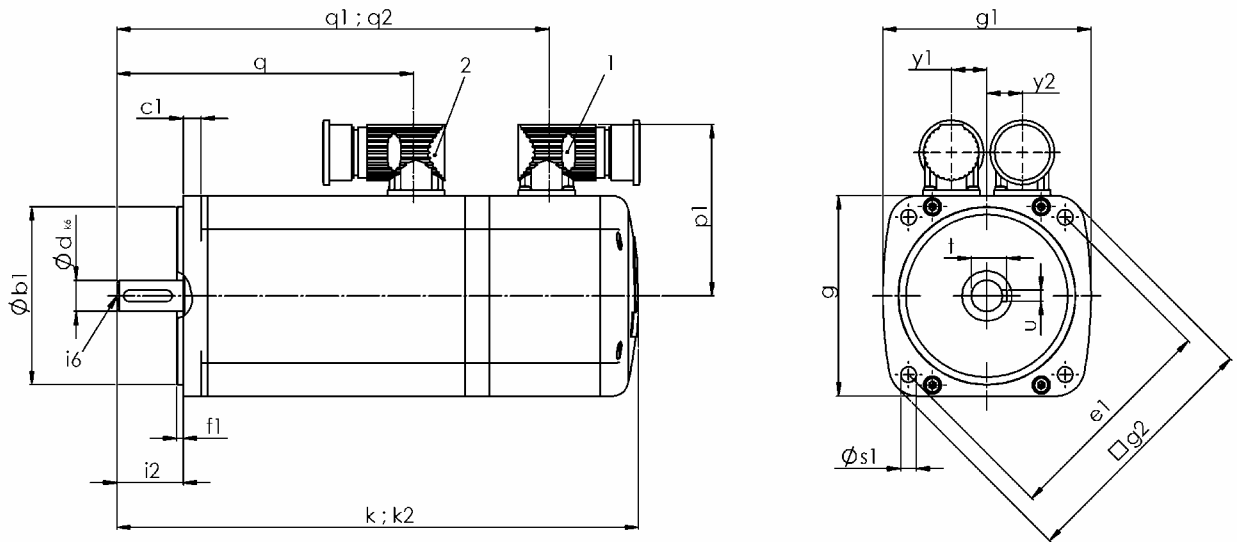

k = motor with encoder  
 k2 = motor with brake and encoder  
 q1 = motor with encoder  
 q2 = motor with brake and encoder

i6 = Centring with internal thread acc. to DIN 332 form D  
 1 = Encoder connector  
 2 = Connector for main connection/brake (use only up to 44 A)

- DC link voltage of 540 V motors
- Key: Motors are also available with key DIN 6885.
- IP 65 type of protection is ensured with mounted connectors only.
- Shaft gland protection type is IP64

Type	Flange		c1	e1	f1	i2	s1	Shaft			Motor					Brake									
	a1	b1						d	t	u	g2	g	g1	k	m1	p1	q	q1	y	y1	y2	s2	s3	k2	q2
45 S	-	80	8	100	3	30	7	14	16	5	115	90	94	240	-	75	134	195	-	16	16	-	-	300	260
45 M														270			164	225						330	290
45 L														300			194	255						360	320

Version IM B5	Type of protection IP 65	Cooling method IC 0041	
---------------	--------------------------	------------------------	--

**DSD 56 / 71 / 100 standard version,  
main connection with terminal box**

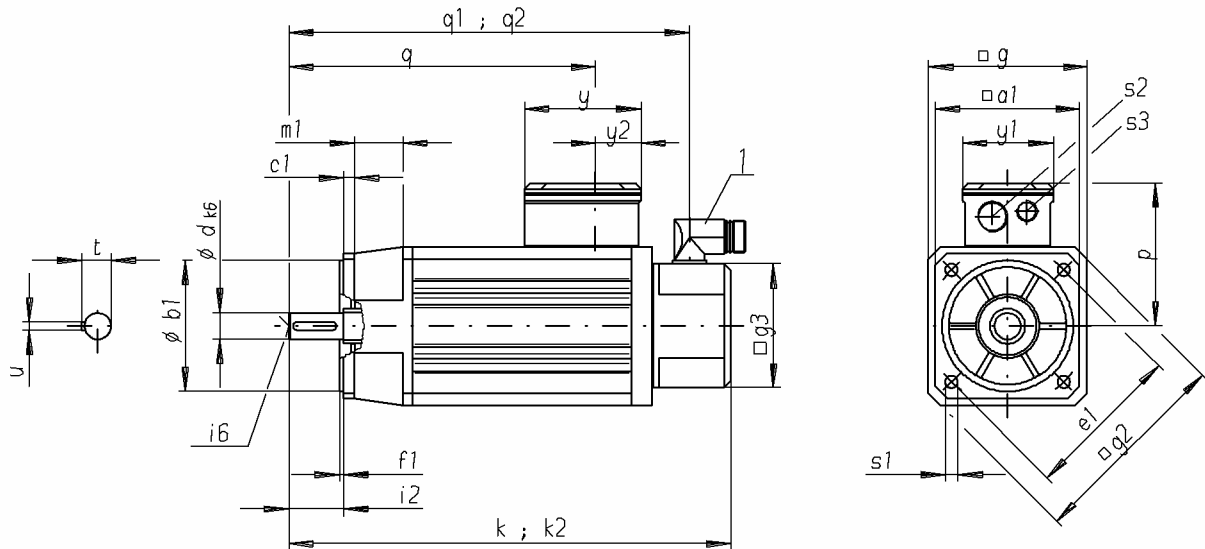

- k = motor with encoder
- k2 = motor with brake and encoder
- q1 = motor with encoder
- q2 = motor with brake and encoder

- i6 = Centring with internal thread acc. to DIN 332 form D
- 1 = Encoder connector

- DC link voltage of 540 V motors
- Key: Motors are also available with key DIN 6885.
- Brake: When a brake is mounted the dimensions remain unchanged.
- IP 65 type of protection is ensured with mounted connectors only.
- Shaft gland protection type is IP64

Type	Flange			e1	f1	i2	s1	Shaft			Motor						Brake								
	a1	b1	c1					d	t	u	g2	g	g3	k	m1	p	q	q1	s2	s3	y	y1	y2	k2	q2
56 S	120	110	9	130	3.5	50	9	24	27	8	150	115	90	291	28	103	183	261	M20	M16	85	66	33	376	346
56 M													329			221	299							414	384
56 L													367			259	337							452	422
71 S	142	130	10	165	3.5	58	12	28	31	8	186	142	90	337	32	129	230	307	M25	M16	110	70	35	421	391
71 M													377			270	347							461	431
71 L													417			310	387							501	471
100 S	190	180	12	215	4	80	14	38	41	10	250	190	90	408	38	174	288	378	M16	M40	150	135	37	528	498
100 M													460			340	430							580	550
100 L													512			392	482							632	602

Version IM B5	Type of protection IP 65	Cooling method IC 0041	
---------------	--------------------------	------------------------	--

DSD 56 / 71 / 100 standard version,  
main connection with connector

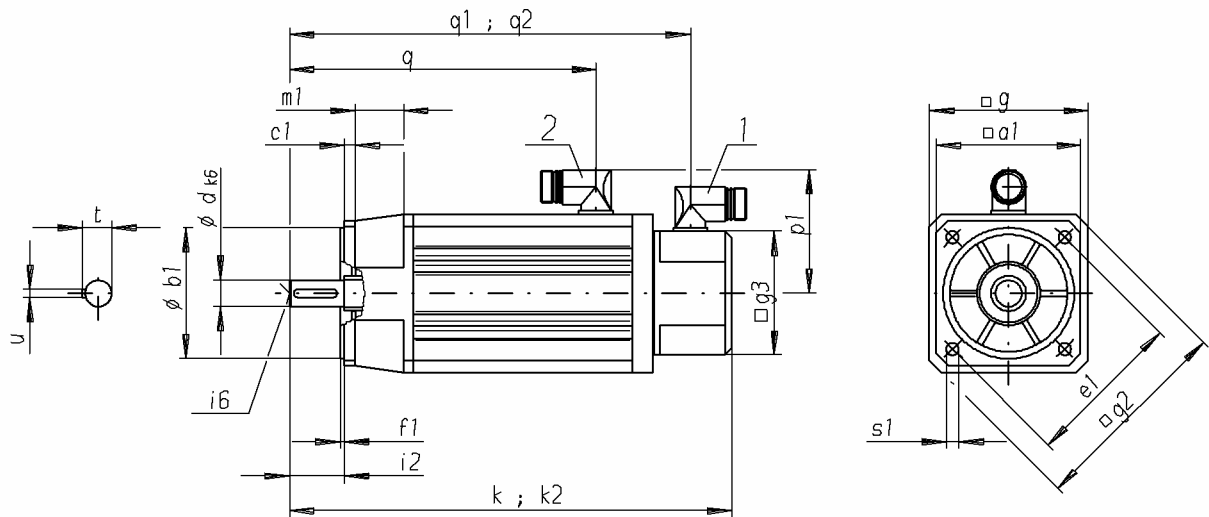

- k = motor with encoder
- k2 = motor with brake and encoder
- q1 = motor with encoder
- q2 = motor with brake and encoder

- i6 = Centring with internal thread acc. to DIN 332 form D
- 1 = Encoder connector
- 2 = Connector for main connection/brake (use only up to 44 A)

- DC link voltage of 540 V motors
- Key: Motors are also available with key DIN 6885.
- IP 65 type of protection is ensured with mounted connectors only.
- Shaft gland protection type is IP64

Type	Flange								Shaft			Motor										Brake			
	a1	b1	c1	e1	f1	i2	s1	d	t	u	g2	g	g3	k	m1	p1	q	q1	y	y1	y2	s2	s3	k2	q2
56 S	120	110	9	130	3.5	50	9	24	27	8	150	115	90	291	28	123	183	261	-	-	-	-	-	376	346
56 M														329			221	299						414	384
56 L														367			259	337						452	422
71 S	142	130	10	165	3.5	58	12	28	31	8	186	142	90	337	32	136	230	307	-	-	-	-	-	421	391
71 M														377			270	347						461	431
71 L														417			310	387						501	471
100 S	190	180	12	215	4	80	14	38	41	10	250	190	90	408	38	160	288	378	-	-	-	-	-	528	498
100 M														460			340	430						580	550
100 L														512			392	482						632	602

Version IM B5	Type of protection IP 65	Cooling method IC 0041		
---------------	--------------------------	------------------------	--	--

**DSD 56 / 71 / 100 standard version with fan,  
main connection with terminal box**

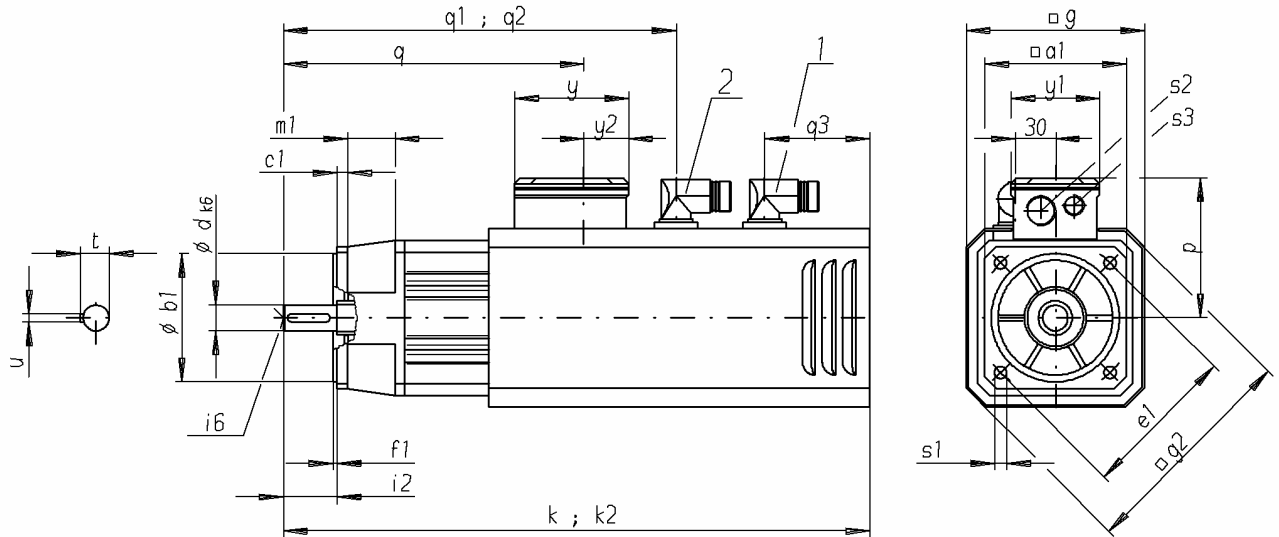

- k = motor with encoder
- k2 = motor with brake and encoder
- q1 = motor with encoder
- q2 = motor with brake and encoder

- i6 = Centring with internal thread acc. to DIN 332 form D
- 1 = Fan connector
- 2 = Encoder connector

- DC link voltage of 540 V motors
- Key: Motors are also available with key DIN 6885.
- IP 65 type of protection is ensured with mounted connectors only.
- Shaft gland protection type is IP64

Type	Flange			e1	f1	i2	s1	Shaft			Motor										Brake								
	a1	b1	c1					d	t	u	g2	g	k	m1	p	q	q1	q3	y	y1	y2	s2	s3	k2	q2				
56 S	120	110	9	130	3.5	50	9	24	27	8	185	140	426	28	103	183	261	124	85	66	33	M20	M16	511	346				
56 M													464			221	299								549	384			
56 L													502			259	337									587	422		
71 S	142	130	10	165	3.5	58	12	28	31	8	230	180	466	32	129	230	307	124	110	70	35	M25	M16	550	391				
71 M													506			270	347									590	431		
71 L													546			310	387										630	471	
100 S	190	180	12	215	4	80	14	38	41	10	275	215	537	38	174	288	378	124	150	135	37	M16	M40	657	498				
100 M													589			340	430										709	550	
100 L													641			392	482											761	602

Version IM B5	Type of protection IP 54	Cooling method IC 0641	
---------------	--------------------------	------------------------	--

**DSD 56 / 71 / 100 standard version with fan,  
main connection with connector**

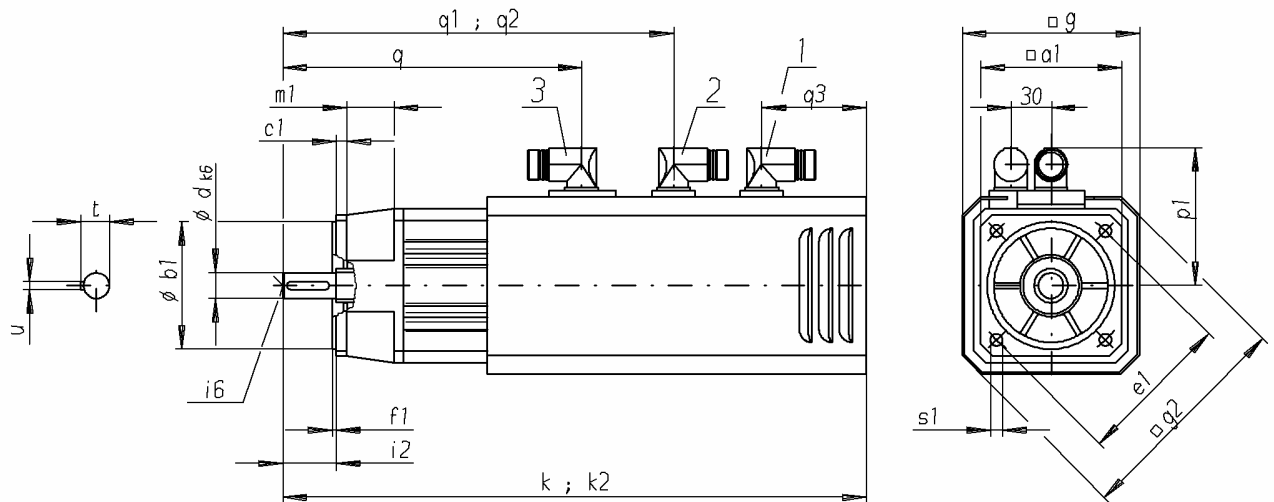

- k = motor with encoder
- k2 = motor with brake and encoder
- q1 = motor with encoder
- q2 = motor with brake and encoder

- i6 = Centring with internal thread acc. to DIN 332 form D
- 1 = Fan connector
- 2 = Encoder connector
- 3 = Connector for main connection/brake

- DC link voltage of 540 V motors
- Key: Motors are also available without key
- IP 65 type of protection is ensured with mounted connectors only.
- Shaft gland protection type is IP64

Type	Flange			e1	f1	i2	s1	Shaft			Motor										Brake				
	a1	b1	c1					d	t	u	g2	g	k	m1	p1	q	q1	q3	y	y1	y2	s2	s3	k2	q2
56 S	120	110	9	130	3.5	50	9	24	27	8	180	134	426	28	123	183	261	124	-	-	-	-	-	511	346
56 M													464			221	299							549	384
56 L													502			259	337							587	422
71 S	142	130	10	165	3.5	58	12	28	31	8	230	178	466	32	136	230	307	124	-	-	-	-	-	550	391
71 M													506			270	347							590	431
71 L													546			310	387							630	471
100 S	190	180	12	215	4	80	14	38	41	10	284	224	537	38	160	288	378	124	-	-	-	-	-	657	498
100 M													589			340	430							709	550
100 L													641			392	482							761	602

Version IM B5	Type of protection IP 54	Cooling method IC 0641	
---------------	--------------------------	------------------------	--

## Motor cables

### General

The motor cables are highly flexible trailing cables with overall shielding. They comply with the regulations VDE, UL and CSA.

The control cables are integrated as star-quads integriert. When the sincos encoder is used the brake triggering and the connection of the thermal sensor are brought out via the main connector.

The cables are particularly suitable for the optimum use of cable racks thanks to their low cross-section, low weight and non-impeding surface. They can thus be efficiently used in trailing chains.

The overall shielding with an optical coverage of more than 85% makes it an EMC uncritical cable.

The connector size is designed in accordance with the motor's standstill current  $I_0$ .

### Technical data

#### Technical description

- Sheath resistance against media such as coolants, machine and gearbox oils
- Abrasion resistance because of a special surface in cable racks and trailing chains
- High-flexible, trailing cable
- Sheath surface not blocking, satin-finish
- Shield made of tinned copper braid with optical coverage of  $\geq 85\%$
- Core insulation made of TPE or polyester, sheath material PUR halogene-free
- Cable FCF-free and silicone-free
- Behavior in case of fire: fire-inhibiting, halogene-free
- Cable color in RAL 1028, melon yellow
- Labelling with Baumüller sign, VDE, UL and CSA sign
- Minimum bending radius for flexible use  $12 \times D$

#### Nominal voltage

U<sub>0</sub>/U 600 / 1000 V (power cores)

U 24 V DC (control cores)

#### Core lettering

Power cores U, VV, WWW

Colored control cable pairs as star-quads in red, white, black, yellow

Assignment of pairs red – black (brake),

white – yellow (temperature)

#### Cable data

Cable cross-section	Nominal current [A] <sup>1)</sup>	Cable diameter [mm]
4×1.5 mm <sup>2</sup> 4×0.75 mm <sup>2</sup>	15	11.7 – 12.3
4×2.5 mm <sup>2</sup> 4×0.75 mm <sup>2</sup>	21	12.7 – 14.6
4×4 mm <sup>2</sup> 4×0.75 mm <sup>2</sup>	28	14.2 – 15.4
4×6 mm <sup>2</sup> 4×0.75 mm <sup>2</sup>	36	16.6 – 17.9
4×10 mm <sup>2</sup> 4×0.75 mm <sup>2</sup>	50	20.5 – 21.5
4×16 mm <sup>2</sup> 4×0.75 mm <sup>2</sup>	66	23.0 – 25.8
4×25 mm <sup>2</sup> 2×(2×1.5 mm <sup>2</sup> )	84	26.3 – 29.7
4×35 mm <sup>2</sup> 2×(2×1.5 mm <sup>2</sup> )	104	30.8 – 32.5

- 1) Current carrying capacity acc. to table 5 laying type C or E  
(VDE 0113 / EN 60 204 Part 1 issue 1997)  
Ambient temperature 40°C

**Cable – connector assignment**

Cable cross-sections	nominal current [A]	Male connector 540 V Volume
4×1.5 mm <sup>2</sup> 4×0.75 mm <sup>2</sup>	15	1
4×2.5 mm <sup>2</sup> 4×0.75 mm <sup>2</sup>	21	1.5
4×4 mm <sup>2</sup> 4×0.75 mm <sup>2</sup>	28	1.5
4×6 mm <sup>2</sup> 4×0.75 mm <sup>2</sup>	36	1.5
4×10 mm <sup>2</sup> 4×0.75 mm <sup>2</sup>	50	1.5

The connectors must be designed with respect to the  $I_0$  motor current. For the laying of the cables, the current carrying capacity acc. to table 5 laying type C or E (VDE 0113 / EN 60 204 Part 1 issue 1997) and an ambient temperature of 40°C must be considered.

Cables of 2.5 mm<sup>2</sup> can be laid up to 100 m without additional filters, when larger cross-sections used, up to 40 m are permissible. The terminal voltage at the motor must be < 1kV. When longer cables are used, filters must be installed between converter and motor.

**Application notes****Operating temperature**

The cables can be operated within a temperature range from –20°C to +80°C.

**Cable laying at the motor**

The cables must not touch the motor surface.

**Smallest permissible bending radii**

12 times outer cable diameter.

Smaller bending radii are possible with reduced service life.

## Main connection cables / Assembled cable with connector

### Nominal current: 15 A

Cable 4 x 1.5 mm<sup>2</sup> + 4x 0.75 mm<sup>2</sup>  
with connector size 1

Length in m	Article no.
5	324781
7	324782
10	324783
15	324784
20	324785
25	324786
30	324787
35	324788
40	324789
50	324790
75	324791
100	324792

### Nominal current: 36 A

Cable 4 x 6 mm<sup>2</sup> + 4x 0.75 mm<sup>2</sup>  
with connector size 1.5

Length in m	Article no.
5	326600
7	326601
10	326602
15	326603
20	326604
25	326605
30	326606
35	326607
40	326608

### Nominal current: 21 A

Cable 4 x 2.5 mm<sup>2</sup> + 4x 0.75 mm<sup>2</sup>  
with connector size 1.5

Length in m	Article no.
5	326577
7	326578
10	326579
15	326580
20	326581
25	326582
30	326583
35	326584
40	326585
50	326586
75	326587
100	326588

### Nominal current: 50 A

Cable 4 x 10 mm<sup>2</sup> + 4x 0.75 mm<sup>2</sup>  
with connector size 1.5

Length in m	Article no.
5	326609
7	326610
10	326611
15	326612
20	326613
25	326614
30	326615
35	326616
40	326617

### Nominal current: 28 A

Cable 4 x 4 mm<sup>2</sup> + 4x 0.75 mm<sup>2</sup>  
with connector size 1.5

Length in m	Article no.
5	326589
7	326591
10	326592
15	326593
20	326594
25	326596
30	326597
35	326598
40	326599

### Connector

Type	Article no.
Size 1 f. 4x1.5mm <sup>2</sup>	261740
Size 1.5 f. 4x2.5mm <sup>2</sup> o. 4mm <sup>2</sup>	326574
Size 1.5 f. 4x6mm <sup>2</sup> o.10mm <sup>2</sup>	326569

Larger cable cross-sections on request.

Longer cables can also be used. The terminal voltage at the motor must be < 1kV. In this case, however, filters must be installed between converter and motor.

## Encoder cables

### General

A fully preassembled encoder cable is used for all encoder systems. Motor connection is via a 12-pin round signal connector and converter connection via a 15-pin sub-D plug. The encoder cables are available as 'trailing' and 'non-trailing' cables. The trailing cable is suitable for use in trailing chains, for example. As opposed to the 'non-trailing' cable, the cable sheath consists of tougher PUR for use in environments with acids and bases (coolants) instead of PVC. Up to a length of 10 m, the cables are available in 1 m sections (1 m, 2 m, 10 m). From a cable length of 10 m, the sections come in 5 m intervals (10 m, 15 m, ...).

In the case of servo motors, the resolver encoder system links the temperature sensor with the converter via the encoder cable.

### Technical data

#### 1. Technical description – non-trailing

- LiYCY, 5x (2x0.14mm<sup>2</sup>) + 2 x 0.5mm<sup>2</sup> copper lead, twisted pair
- PVC sheath, grey
- 1<sup>st</sup> end: 12-pin signal circular connector with 12 female contacts
- 2<sup>nd</sup> end: 15-pin D-Sub connector with male contacts and locking screws 4-4OUNC
- Baumüller labelling, black
- Outer diameter 9.0 mm (+/-3mm)
- Bending radius:  $r \geq 60$  mm (fixed installation),  $r \geq 135$  mm (flexible use)
- Nominal voltage: 250V<sub>AC</sub>

#### 2. Technical description – trailing

- Li12YC11Y, 5x (2x0.14mm<sup>2</sup>) + 2 x 0.5mm<sup>2</sup> copper lead, twisted pair
- PU sheath, black
- 1<sup>st</sup> end: 12-pin signal circular connector with 12 female contacts
- 2<sup>nd</sup> end: 15-pin D-Sub connector with male contacts and locking screws 4-4OUNC
- Baumüller labelling, white
- Outer diameter 9.0 mm (+/-3mm)
- Bending radius:  $r \geq 70$  mm (fixed installation),  $r \geq 100$  mm (flexible use)
- Nominal voltage: 300V<sub>AC</sub>

**Application notes**

- Operating temperature

	trailing	non-trailing
Limit temperature	at the surface	at the surface
no / few movements	-40 °C to +80 °C	- 30 °C to +80 °C
continuous movements	- 30 °C to +80 °C	-5 °C to + 70 °C

- Cable laying at the motor

The cables must not touch the motor surface.

**Ordering data**

Encoder cables / preassembled cables with connector

**Encoder cable**

**Non-trailing, assembled**

Cable 5 x (2x014mm<sup>2</sup>) + 2 x 0.5 mm<sup>2</sup> with connector

**Trailing, assembled**

Cable 5 x (2x014mm<sup>2</sup>) + 2 x 0.5 mm<sup>2</sup> with connector

Length in m	Article no.	Length in m	Article no.
1	243601	3	246658
2	211338	4	243379
3	219333	5	239540
4	231166	6	242954
5	209879	8	239541
6	220197	10	239542
7	216455	15	239543
8	220429	20	239544
10	210052	25	239545
15	215716	30	239546
20	218568	35	239547
25	218569	40	240520
30	217094	45	240521
35	216444	50	240522
40	217095	55	244033
45	217567	60	245484
50	217568		
55	217569		
60	217570		
70	232088		
		<b>Encoder connector</b>	Article no.
		Encoder connector	201833

**Commissioning and maintenance instructions**

Please contact us for our commissioning and maintenance instructions for motor commissioning.



## Three-phase synchronous motors DS 45 - 100..540V

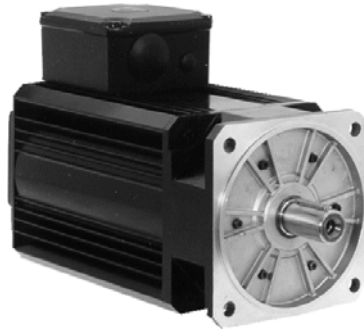

### General technical data

Version:	IM B5	Horizontal mounting
	IM V1	Vertical mounting, shaft end to the bottom
	IM V3	Vertical mounting, shaft end to the top
Type of protection:	IP65	Surface-cooled, <b>without</b> fan, DIN 40050, DIN 40053
	IP54	Surface-cooled, <b>with</b> fan
Shaft gland:	IP64	Standard
	IP65	with shaft sealing ring (option)
Connection:		
Main connection	U V W	Terminal box Connector (option) Frame size 45 with connector as standard
Control connection		12-pin connector
Brake		in the main connection
Thermal sensor		in control connection (for resolver only)
Cooling method:	IC 0041	completely enclosed machine surface-cooled no fan
	IC 0641	as above, but with fan (air flow direction from B to A end)
Thermal sensor:		Linear thermal sensor for evaluation in the controller
Temperature rise:	$\Delta\theta = 105K$	Insulation class F acc. to EN 60034
Temperature range:	0...+ 40°C	
Storage:	-30°C...+85°C	
Paint:	black matt	RAL 9005
Lager:	$\geq 20,000h$	Service life
Balance quality:	N	According to DIN ISO 2373
	R, S	On request
Vibration-resistant up to:	radial 3g	20 Hz to 2 kHz acc. to EN 60068-2-6
	axial 0.5g	20 Hz to kHz acc to EN 60068-2-6 Higher vibration resistance on request
Flange:	acc. to IEC standard	Dimension b1: Tolerance j6
Shaft end:	cylindrical	According to DIN 748 with shaft key DIN 6885; also available without keyway Dimension d: Tolerance k6 Centering with internal thread acc. to DIN 332 form D
Holding brake:		Option
Actual speed encoder:	2-pin resolver	
	Sincos encoder (option)	Other encoders on request

### Ratings definition

The ratings (torques) listed in the table apply to continuous operation (S1) with nominal speed at a maximum ambient temperature of 40°C with the machine being installed below 1000m a.m.s.l.

If motors are to be operated in an ambient temperature of more than 40 °C or altitudes above 1000 m a.m.s.l., the required list nominal power  $P_L$  (list torque  $M_n$ ) results from the product of the factors  $k_1$ ,  $k_2$  specified in the table and the required power  $P$  (torque  $M$ ).

Ambient temperature	40 °C	45°C	50 °C	55°C	60°C	For ambient temperatures above 40 °C and enclosed installation of motors, it is absolutely necessary to contact the manufacturer, because design changes may be necessary.
Correction factor $k_1$	1	1.06	1.13	1.22	1.34	
Altitude a.m.s.l. up to	1.000 m	2.000 m	3.000 m	4.000 m	5.000 m	If, with increasing site altitude above 1000 m, the ambient temperature decreases by approx. 10 °C per 1000 m increase in altitude, no power correction is necessary.
Correction factor $k_2$	1	1.07	1.16	1.27	1.55	

### Winding isolation and temperature rise

All machines of this series are designed in insulation class F according to EN 60034 for a permissible winding temperature of 105 K at a room temperature of up to 40 °C. The insulation is resistant against gases and vapours of combustible materials and it meets the requirements placed on a moisture-proof and tropical insulation.

A special insulation that can be obtained for an extra charge is necessary if concentrated acid vapours and metallic powders occur, with a permanent relative air humidity of more than 80% and as protection against termite and mould fungus attacks.

In the case of converters with a DC link voltage > 500 V, the cables between the converter and the motor must not be longer than 20 meters. For longer cables, additional measures (e.g. motor filters) must be provided. The maximum permissible terminal voltage is 1000 V.

### Explanation of the motor data

$M_0, I_0$	Nominal torque (Nm) with nominal current (A) with speed $\geq 1 \text{ min}^{-1}$ without time limit, $I_0$ is the r.m.s. value
$M_N, I_N$	Nominal torque (Nm) with Nominal current (A) with nominal speed $n_N$ in continuous operation (S1); $T_A = 40 \text{ °C}^*$
$M_{S3-40\%}, I_{S3-40\%}$	Torque and speed for intermittent operation S3-40% duty time, cycle of 10 minutes
$n_N$	Nominal speed ( $\text{min}^{-1}$ )
$k_E$	Motor e.m.f. referred to $1000 \text{ min}^{-1}$ (voltage constant)
$k_T$	Torque constant: $k_T \times I_0 = M_0 + M_R$ (intrinsic moment)
$k_D$	Torque loss referred to $1000 \text{ min}^{-1}$ (eddy-current loss)
$M_R$	Bearing friction including hysteresis torque
$m$	Weight in kg
$J$	Rotor inertia incl. resolver without holding brake (kg cm <sup>2</sup> )

The specified ratings / torques at nominal speed are achieved with a chopping frequency of  $\geq 4 \text{ kHz}$  in the power unit of the converter. A chopping frequency of  $> 6 \text{ kHz}$  is recommended.

\* A part of the loss in the motor is dissipated via the flange. The temperature at the flange must not exceed 65°C!

### Basic calculation

Valid under the prerequisite that torque and speed are within the speed-torque characteristic.

Motor current  $I$  for speed  $n$  and torque  $M$

Torque  $M$  for any speed and current  $I$

$$I = \frac{M + M_R + k_D * n/10^3}{k_T} [A].$$

$$M = I * k_T - (M_R + k_D * \frac{n}{10^3}) [Nm]$$

### Performance overview

#### DS (Three-phase current synchronous

	Frame size	Standstill torque
Standard version without fan	DS 45...100	0.8 - 57 Nm
Standard version with fan	DSO 56...100	4.8 - 84 Nm
Short version without fan	DS 56...100	1.9 – 24 Nm
Standard version with holding brake	DSG 45...100	0.8 – 57 Nm
Standard version with holding brake and fan	DSOG 56...DSOG 100	4.8 – 84 Nm
Short version with brake	DSG 56...DSG 100	1.9 – 24 Nm

### Type key

DS	O	G	100	K	2	5	
							DC link voltage: 5      540 V
							Nominal speed: 1:      1200 min <sup>-1</sup> 2:      2000 min <sup>-1</sup> 3:      3000 min <sup>-1</sup> 4:      4000 min <sup>-1</sup> 6:      6000 min <sup>-1</sup>
							Length: Standard      Short K      A S      B M      C L      D
							Frame size: 45 56 71 100
							Holding brake: without with      G
							Fan: without with      O
							Motor type: DS      Three-phase synchronous

**Technical data**
**DS standard version**

Type	$n_N$ ( $1/min$ )	$M_0$ (Nm)	$M_0$ (lbf ft)	$M_N$ (Nm)	$M_N$ (lbf ft)	$M_{S3-40\%}$ (Nm)	$M_{S3-40}$ (lbf ft)	$I_0$ (A)	$I_N$ (A)	$I_{S3-40\%}$ (A)
DS 45 S	3000	0.8	0.6	0.8	0.6	1.0	0.74	0.7	0.7	0.8
DS 45 S	4000			0.7	0.5	1.2	0.89	0.9	0.8	1.3
DS 45 S	6000			0.6	0.4	1.0	0.74	1.4	1.1	1.7
DS 45 M	3000	1.7	1.3	1.6	1.2	2.4	1.8	1.3	1.3	1.9
DS 45 M	4000			1.5	1.1	2.3	1.7	1.8	1.6	2.4
DS 45 M	6000			1.1	0.8	2.0	1.5	2.7	1.9	3.2
DS 45 L	3000	3.2	2.4	2.9	2.1	4.4	3.2	2.5	2.3	3.4
DS 45 L	4000			2.7	2.0	4.2	3.1	3.3	2.9	4.3
DS 45 L	6000			2.0	1.5	3.8	2.8	4.9	3.3	6.0
DS 56 S	2000	3.8	2.8	3.7	2.7	5.4	4.0	1.8	1.8	2.6
DS 56 S	3000			3.6	2.7	5.4	4.0	2.5	2.4	3.6
DS 56 S	4000			3.4	2.5	5.3	3.9	3.2	3.0	4.5
DS 56 S	6000			2.6	1.9	4.7	3.5	5.1	3.8	6.6
DS 56 M	2000	7.0	5.2	6.9	5.1	10.1	7.4	3.0	3.0	4.3
DS 56 M	3000			6.4	4.7	9.8	7.2	4.2	4.0	6.0
DS 56 M	4000			5.6	4.1	9.4	6.9	5.5	4.6	7.6
DS 56 M	6000			2.9	2.1	7.9	5.8	8.0	3.8	9.4
DS 56 L	2000	10.0	7.4	9.5	7.0	14.1	10.4	4.1	4.0	5.8
DS 56 L	3000			8.4	6.2	13.6	10.0	5.9	5.1	8.1
DS 56 L	4000			6.9	5.1	12.7	9.4	7.7	5.6	10.0
DS 56 L	6000			0.6	0.4	9.8	7.2	11.1	1.5	11.5
DS 71 K	2000	10.5	7.7	10.3	7.6	15.2	11.2	4.4	4.4	6.4
DS 71 K	3000			9.5	7.0	14.8	10.9	6.3	5.9	9.0
DS 71 K	4000			8.2	6.0	14.2	10.5	8.3	6.7	11.4
DS 71 K	6000			3.8	2.8	11.8	8.7	11.9	5.0	13.9
DS 71 S	2000	16.5	12.2	15.4	11.4	23.4	17.3	6.6	6.3	9.5
DS 71 S	3000			13.4	9.9	22.4	16.5	9.6	8.1	13.3
DS 71 S	4000			10.3	7.6	20.7	15.3	12.4	8.2	16.0
DS 71 S	6000			0.0	0.0	16.4	12.1	18.6	0.0	20.1
DS 71 M	2000	22.0	16.2	20.0	14.8	27.6	20.4	8.4	7.8	10.7
DS 71 M	3000			16.3	12.0	28.3	20.9	12.3	9.5	16.2
DS 71 M	4000			10.4	7.7	16.3	12.0	15.8	8.2	12.4
DS 71 M	6000			0.0	0.0	18	13.3	24.8	0.0	13.8
DS 100 K	1200	25.0	18.4	24.8	18.3	36.3	26.8	6.3	6.3	9.2
DS 100 K	2000			23.3	17.2	35.9	26.5	10.0	9.5	14.4
DS 100 K	3000			19.9	14.7	34.4	25.4	14.5	11.9	20.2
DS 100 K	4000			14.7	10.8	31.7	23.4	19.1	11.9	24.7
DS 100 K	6000			0.0	0.0	24.8	18.3	28.2	0.0	19.8
DS 100 S	1200	36.0	26.6	34.7	25.6	51.6	38.1	8.8	8.6	12.6
DS 100 S	2000			31.4	23.2	50.4	37.2	14.0	12.4	19.7
DS 100 S	3000			24.6	18.1	47.0	34.7	20.3	14.4	26.9
DS 100 S	4000			13.8	10.2	41.7	30.8	27.0	11.5	32.1
DS 100 M	1200	46.0	33.9	43.7	32.2	66.0	48.7	11.0	10.5	15.8
DS 100 M	2000			38.2	28.2	63.6	46.9	17.6	15.0	24.6
DS 100 M	3000			27.1	20.0	58.0	42.8	25.9	16.0	33.2
DS 100 L	1200	57.0	42.0	52.1	38.4	79.7	58.8	13.5	12.5	19.0
DS 100 L	2000			44.2	32.6	76.0	56.1	21.4	17.1	28.9
DS 100 L	3000			28.1	20.7	67.7	49.9	32.2	16.9	39.0

Legend

American units
----------------

Type	$n_N$ (1/min)	$k_E$ ( $\frac{V}{1000}$ 1/min)	$k_T$ ( $\frac{Nm}{A}$ )	$k_T$ (lbf ft / A)	$k_D$ ( $\frac{Nm}{1000}$ 1/min)	$M_R$ (Nm)	$M_R$ (lbf ft)	m (kg)	m (lb)	J (kgcm <sup>2</sup> )	J (lb in <sup>2</sup> )
DS 45 S	3000	82.3	1.36	1.00	0.005	0.127	0.094	4.9	10.8	1.5	0.51
DS 45 S	4000	61.8	1.02	0.75							
DS 45 S	6000	41.2	0.68	0.50							
DS 45 M	3000	82.3	1.36	1.00	0.010	0.131	0.097	5.9	13.0	2.1	0.72
DS 45 M	4000	61.8	1.02	0.75							
DS 45 M	6000	41.2	0.68	0.50							
DS 45 L	3000	82.3	1.36	1.00	0.021	0.140	0.103	6.9	15.2	3.4	1.16
DS 45 L	4000	61.8	1.02	0.75							
DS 45 L	6000	41.2	0.68	0.50							
DS 56 S	2000	133	2.2	1.62	0.030	0.154	0.114	6.6	14.6	5.7	1.95
DS 56 S	3000	95.2	1.57	1.16							
DS 56 S	4000	74.6	1.23	0.91							
DS 56 S	6000	46.0	0.76	0.56							
DS 56 M	2000	145.4	2.41	1.78	0.062	0.180	0.133	8.5	18.7	10.2	3.49
DS 56 M	3000	102	1.69	1.25							
DS 56 M	4000	78.8	1.3	0.96							
DS 56 M	6000	54.5	0.9	0.66							
DS 56 L	2000	150	2.48	1.83	0.094	0.208	0.153	10.8	23.8	15.7	5.36
DS 56 L	3000	104.7	1.73	1.28							
DS 56 L	4000	80	1.33	0.98							
DS 56 L	6000	55.6	0.92	0.68							
DS 71 K	2000	147.5	2.44	1.80	0.082	0.230	0.170	12.2	26.9	22.4	7.65
DS 71 K	3000	102.4	1.69	1.25							
DS 71 K	4000	79	1.3	0.96							
DS 71 K	6000	54.3	0.9	0.66							
DS 71 S	2000	152.8	2.53	1.87	0.139	0.280	0.207	16.3	35.9	36.3	12.40
DS 71 S	3000	105.2	1.74	1.28							
DS 71 S	4000	81.5	1.35	1.00							
DS 71 S	6000	56	0.9	0.66							
DS 71 M	2000	161	2.66	1.96	0.202	0.334	0.246	20.5	45.2	50.2	17.15
DS 71 M	3000	109.7	1.81	1.33							
DS 71 M	4000	85.3	1.41	1.04							
DS 71 M	6000	54.5	0.9	0.66							
DS 100 K	1200	243	4.02	2.96	0.195	0.400	0.295	26.1	57.5	74	25.29
DS 100 K	2000	153.5	2.54	1.87							
DS 100 K	3000	106	1.75	1.29							
DS 100 K	4000	80.4	1.33	0.98							
DS 100 K	6000	54.8	0.9	0.66							
DS 100 S	1200	250	4.15	3.06	0.297	0.489	0.361	32.7	72.1	108	36.91
DS 100 S	2000	158	2.61	1.93							
DS 100 S	3000	109	1.8	1.33							
DS 100 S	4000	81.7	1.35	1.00							
DS 100 M	1200	257	4.25	3.13	0.398	0.579	0.427	39.6	87.3	141	48.18
DS 100 M	2000	159.3	2.64	1.95							
DS 100 M	3000	108.6	1.8	1.33							
DS 100 L	1200	257.5	4.26	3.14	0.500	0.668	0.493	48.8	107.6	175	59.80
DS 100 L	2000	162.6	2.69	1.98							
DS 100 L	3000	108.4	1.79	1.32							

DS standard version with fan

Type	$n_N$ ( $1/\text{min}$ )	$M_0$ (Nm)	$M_0$ (lbf ft)	$M_N$ (Nm)	$M_N$ (lbf ft)	$M_{S3-40\%}$ (Nm)	$M_{S3-40\%}$ (lbf ft)	$I_0$ (A)	$I_N$ (A)	$I_{S3-40\%}$ (A)
DSO 56 S	2000	4.8	3.5	4.8	3.5	5.5	4.1	2.2	2.3	2.6
DSO 56 S	3000			4.8	3.5	5.3	3.9	3.1	3.2	3.5
DSO 56 S	4000			4.7	3.5	5.2	3.8	4.0	4.1	4.5
DSO 56 S	6000			4.2	3.1	4.7	3.5	5.9	5.4	6.0
DSO 56 M	2000	9.2	6.8	9.1	6.7	10.3	7.6	3.9	3.9	4.4
DSO 56 M	3000			9.0	6.6	10.1	7.4	5.5	5.5	6.2
DSO 56 M	4000			8.6	6.3	9.6	7.1	7.2	7.0	7.7
DSO 56 M	6000			7.3	5.4	8.5	6.3	10.5	8.8	10.2
DSO 56 L	2000	13.2	9.7	13.1	9.7	14.5	10.7	5.4	5.4	6.0
DSO 56 L	3000			12.5	9.2	14.2	10.5	7.7	7.5	8.5
DSO 56 L	4000			11.7	8.6	13.1	9.7	10.1	9.2	10.3
DSO 56 L	6000			9.2	6.8	11.5	8.5	14.7	10.9	13.4
DSO 71 K	2000	14.0	10.3	13.9	10.3	16.3	12.0	5.8	5.8	6.8
DSO 71 K	3000			13.7	10.1	15.9	11.7	8.4	8.4	9.7
DSO 71 K	4000			13.4	9.9	15.0	11.1	11.0	10.8	12.0
DSO 71 K	6000			11.8	8.7	13.5	10.0	16.0	14.1	16.0
DSO 71 S	2000	23.0	17.0	22.8	16.8	25.6	18.9	9.2	9.2	10.3
DSO 71 S	3000			21.9	16.2	24.5	18.1	13.4	13.0	14.5
DSO 71 S	4000			20.5	15.1	23.4	17.3	17.3	15.8	18.0
DSO 71 S	6000			16.3	12.0	18.1	13.3	25.2	18.9	20.8
DSO 71 M	2000	31.0	22.9	30.2	22.3	33.4	24.6	12.1	11.9	13.2
DSO 71 M	3000			28.6	21.1	33.5	24.7	17.8	16.8	19.6
DSO 71 M	4000			26.2	19.3	29.4	21.7	22.9	20.0	22.3
DSO 71 M	6000			18.8	13.9	25.0	18.4	35.0	22.7	29.6
DSO 100 K	1200	36.0	26.6	35.9	26.5	41.5	30.6	9.0	9.1	10.5
DSO 100 K	2000			35.6	26.3	41.3	30.5	14.3	14.3	16.6
DSO 100 K	3000			35.1	25.9	40.4	29.8	20.9	20.7	23.7
DSO 100 K	4000			33.5	24.7	37.7	27.8	27.5	26.2	29.4
DSO 100 K	6000			27.6	20.4	32.2	23.7	40.5	32.5	37.6
DSO 100 S	1200	53.0	39.1	52.8	38.9	59.0	43.5	12.9	12.9	14.4
DSO 100 S	2000			52.4	38.6	60.1	44.3	20.5	20.5	23.4
DSO 100 S	3000			50.1	37.0	57.2	42.2	29.8	28.7	32.6
DSO 100 S	4000			46.1	34.0	51.2	37.8	39.8	35.5	39.3
DSO 100 M	1200	69.0	50.9	68.8	50.7	77.9	57.5	16.3	16.4	18.6
DSO 100 M	2000			67.5	49.8	75.4	55.6	26.4	26.1	29.1
DSO 100 M	3000			63.1	46.5	69.9	51.6	38.7	36.1	39.9
DSO 100 L	1200	84.0	62.0	83.8	61.8	96.8	71.4	19.9	19.9	23.0
DSO 100 L	2000			81.4	60.0	91.8	67.7	31.5	30.9	34.7
DSO 100 L	3000			75.0	55.3	82.9	61.1	47.4	43.2	47.6

Legend

American units
----------------

Typ	$n_N$ (1/min)	$k_E$ ( $\frac{V}{1000}$ 1/min)	$k_T$ ( $\frac{Nm}{A}$ )	$k_T$ (lbf ft / A)	$k_D$ ( $\frac{Nm}{1000}$ 1/min)	$M_R$ (Nm)	$M_R$ (lbf ft)	m (kg)	m (lb)	J (kgcm <sup>2</sup> )	J (lb in <sup>2</sup> )
DSO 56 S	2000	132.9	2.2	1.62	0.030	0.154	0.114	8.3	18.3	5.7	1.95
DSO 56 S	3000	95.2	1.57	1.16							
DSO 56 S	4000	74.6	1.23	0.91							
DSO 56 S	6000	52.2	0.86	0.63							
DSO 56 M	2000	145.4	2.41	1.78	0.062	0.180	0.133	10.2	22.5	10.2	3.49
DSO 56 M	3000	102.1	1.69	1.25							
DSO 56 M	4000	78.8	1.3	0.96							
DSO 56 M	6000	54.5	0.9	0.66							
DSO 56 L	2000	149.9	2.48	1.83	0.094	0.208	0.153	12.5	27.6	15.7	5.36
DSO 56 L	3000	104.7	1.73	1.28							
DSO 56 L	4000	80.1	1.33	0.98							
DSO 56 L	6000	55.6	0.92	0.68							
DSO 71 K	2000	147.5	2.44	1.80	0.082	0.230	0.170	14.7	32.4	22.4	7.65
DSO 71 K	3000	102.4	1.69	1.25							
DSO 71 K	4000	78.9	1.3	0.96							
DSO 71 K	6000	54.3	0.9	0.66							
DSO 71 S	2000	152.8	2.53	1.87	0.139	0.280	0.207	18.8	41.4	36.3	12.40
DSO 71 S	3000	105.2	1.74	1.28							
DSO 71 S	4000	81.5	1.35	1.00							
DSO 71 S	6000	56	0.9	0.66							
DSO 71 M	2000	160.9	2.66	1.96	0.202	0.334	0.246	23.0	50.7	50.2	17.15
DSO 71 M	3000	109.7	1.81	1.33							
DSO 71 M	4000	85.3	1.41	1.04							
DSO 71 M	6000	54.5	0.9	0.66							
DSO 100 K	1200	243.1	4.02	2.96	0.195	0.400	0.295	29.6	65.3	74	25.29
DSO 100 K	2000	153.5	2.54	1.87							
DSO 100 K	3000	106	1.75	1.29							
DSO 100 K	4000	80.4	1.33	0.98							
DSO 100 K	6000	54.8	0.9	0.66							
DSO 100 S	1200	250.7	4.15	3.06	0.297	0.489	0.361	36.2	79.8	108	36.91
DSO 100 S	2000	158	2.61	1.93							
DSO 100 S	3000	109	1.8	1.33							
DSO 100 S	4000	81.7	1.35	1.00							
DSO 100 M	1200	257.1	4.25	3.13	0.398	0.579	0.427	43.1	95.0	141	48.18
DSO 100 M	2000	159.3	2.64	1.95							
DSO 100 M	3000	108.6	1.8	1.33							
DSO 100 L	1200	257.5	4.26	3.14	0.500	0.668	0.493	52.3	115.3	175	59.80
DSO 100 L	2000	162.6	2.69	1.98							
DSO 100 L	3000	108.4	1.79	1.32							

DS short version

Type	$n_N$ ( $1/\text{min}$ )	$M_0$ (Nm)	$M_0$ (lbf ft)	$M_N$ (Nm)	$M_N$ (lbf ft)	$M_{S3-40\%}$ (Nm)	$M_{S3-40\%}$ (lbf ft)	$I_0$ (A)	$I_N$ (A)	$I_{S3-40\%}$ (A)
DS 56 A	2000	1.9	1.4	1.8	1.3	2.7	2.0	1.0	0.9	1.4
DS 56 A	3000			1.8	1.3	2.8	2.1	1.5	1.4	2.2
DS 56 A	4000			1.8	1.3	2.7	2.0	2.0	2.0	2.9
DS 56 A	6000			1.4	1.0	2.5	1.8	3.1	2.5	4.1
DS 56 B	2000	3.7	2.7	3.6	2.7	5.4	4.0	1.7	1.7	2.5
DS 56 B	3000			3.6	2.7	5.3	3.9	2.4	2.4	3.5
DS 56 B	4000			3.3	2.4	5.1	3.8	3.1	2.9	4.4
DS 56 B	6000			2.4	1.8	4.6	3.4	4.6	3.3	5.8
DS 71 B	2000	7.0	5.2	6.9	5.1	10.2	7.5	3.5	3.5	5.1
DS 71 B	3000			6.5	4.8	10.0	7.4	5.3	5.1	7.6
DS 71 B	4000			5.7	4.2	9.6	7.1	7.1	6.1	9.9
DS 71 B	6000			3.3	2.4	8.2	6.0	10.8	5.9	13.1
DS 71 C	2000	10.0	7.4	9.8	7.2	14.6	10.8	4.2	4.2	6.1
DS 71 C	3000			8.9	6.6	14.2	10.5	6.1	5.5	8.7
DS 71 C	4000			7.4	5.5	13.4	9.9	7.9	6.2	10.8
DS 71 C	6000			2.2	1.6	10.8	8.0	11.6	3.4	13.0
DS 100 B	1200	12.5	9.2	12.4	9.1	18.8	13.9	3.7	3.7	5.6
DS 100 B	2000			12.3	9.1	18.8	13.9	6.3	6.3	9.5
DS 100 B	3000			11.5	8.5	18.4	13.6	9.5	9.0	14.0
DS 100 B	4000			9.8	7.2	17.5	12.9	12.8	10.5	18.0
DS 100 B	6000			3.7	2.7	14.3	10.5	19.5	7.4	22.9
DS 100 C	1200	18.5	13.6	18.4	13.6	27.2	20.1	5.5	5.5	8.1
DS 100 C	2000			17.8	13.1	27.1	20.0	9.2	9.0	13.6
DS 100 C	3000			15.5	11.4	26.1	19.3	13.9	12.1	19.8
DS 100 C	4000			12.1	8.9	24.3	17.9	18.7	13.0	24.9
DS 100 C	6000			0.0	0.0	20.1	14.8	28.0	0.0	31.0
DS 100 D	1200	24.0	17.7	23.8	17.6	35.2	26.0	6.0	6.1	8.9
DS 100 D	2000			22.3	16.4	34.7	25.6	9.6	9.1	14.0
DS 100 D	3000			18.6	13.7	33.0	24.3	14.0	11.2	19.5
DS 100 D	4000			13.0	9.6	30.1	22.2	18.5	10.8	23.7
DS 100 D	6000			0.0	0.0	22.8	16.8	18.5	0.0	18.5

Legend

American units
----------------

Typ	$n_N$ (1/min)	$k_E$ (V/1000 1/min)	$k_T$ (Nm/A)	$k_T$ (lbf ft / A)	$k_D$ (lbf ft / A)	$M_R$ (Nm)	$M_R$ (lbf ft)	m (kg)	m (lb)	J (kgcm <sup>2</sup> )	J (lb in <sup>2</sup> )
DS 56 A	2000	123.5	2.04	1.50	0.014	0.14	0.103	5.5	12.1	3.0	1.03
DS 56 A	3000	82.3	1.36	1.00							
DS 56 A	4000	61.8	1.02	0.75							
DS 56 A	6000	41.2	0.68	0.50							
DS 56 B	2000	132.9	2.2	1.62	0.030	0.154	0.114	6.7	14.8	5.5	1.88
DS 56 B	3000	95.2	1.57	1.16							
DS 56 B	4000	74.6	1.23	0.91							
DS 56 B	6000	52.2	0.86	0.63							
DS 71 B	2000	123.5	2.04	1.50	0.054	0.206	0.152	10.3	22.7	14.6	4.99
DS 71 B	3000	82.3	1.36	1.00							
DS 71 B	4000	61.8	1.02	0.75							
DS 71 B	6000	41.2	0.68	0.50							
DS 71 C	2000	147.5	2.44	1.80	0.082	0.230	0.170	12.4	27.3	21.5	7.35
DS 71 C	3000	102.4	1.69	1.25							
DS 71 C	4000	78.9	1.3	0.96							
DS 71 C	6000	54.3	0.9	0.66							
DS 100 B	1200	205.8	3.4	2.51	0.094	0.31	0.229	18.9	41.7	36.5	12.47
DS 100 B	2000	123.5	2.04	1.50							
DS 100 B	3000	82.3	1.36	1.00							
DS 100 B	4000	61.7	1.02	0.75							
DS 100 B	6000	41.2	0.68	0.50							
DS 100 C	1200	205.8	3.4	2.51	0.144	0.355	0.262	22.5	49.6	53.3	18.21
DS 100 C	2000	123.5	2.04	1.50							
DS 100 C	3000	82.3	1.36	1.00							
DS 100 C	4000	61.8	1.02	0.75							
DS 100 C	6000	41.0	0.68	0.50							
DS 100 D	1200	243.1	4.02	2.96	0.195	0.400	0.295	26.3	58.0	70.0	23.92
DS 100 D	2000	153.5	2.54	1.87							
DS 100 D	3000	106	1.75	1.29							
DS 100 D	4000	80.4	1.33	0.98							
DS 100 D	6000	54.8	0.9	0.66							

## Radial force diagrams

### Permissible radial forces $F_R$ at the shaft end

All bearings are dimensioned for a service life of approx. 20.000 operating hours; the loads specified in the following must not be exceeded. The specified permissible radial forces  $F_R$  are valid only for horizontal mounting of the motor without additional axial forces.

### Axial load of the motor shaft

When mounting clutches, pulleys, etc. onto the motor shaft, axial forces must not occur! Therefore use the internal thread of the shaft end as assembly aid.

### Example

Force acting on the end of the shaft end (for force acting on the middle of the shaft end  $F_r \times 1.1$ )  
 Bearing life 20.000 h; shaft end with keyway

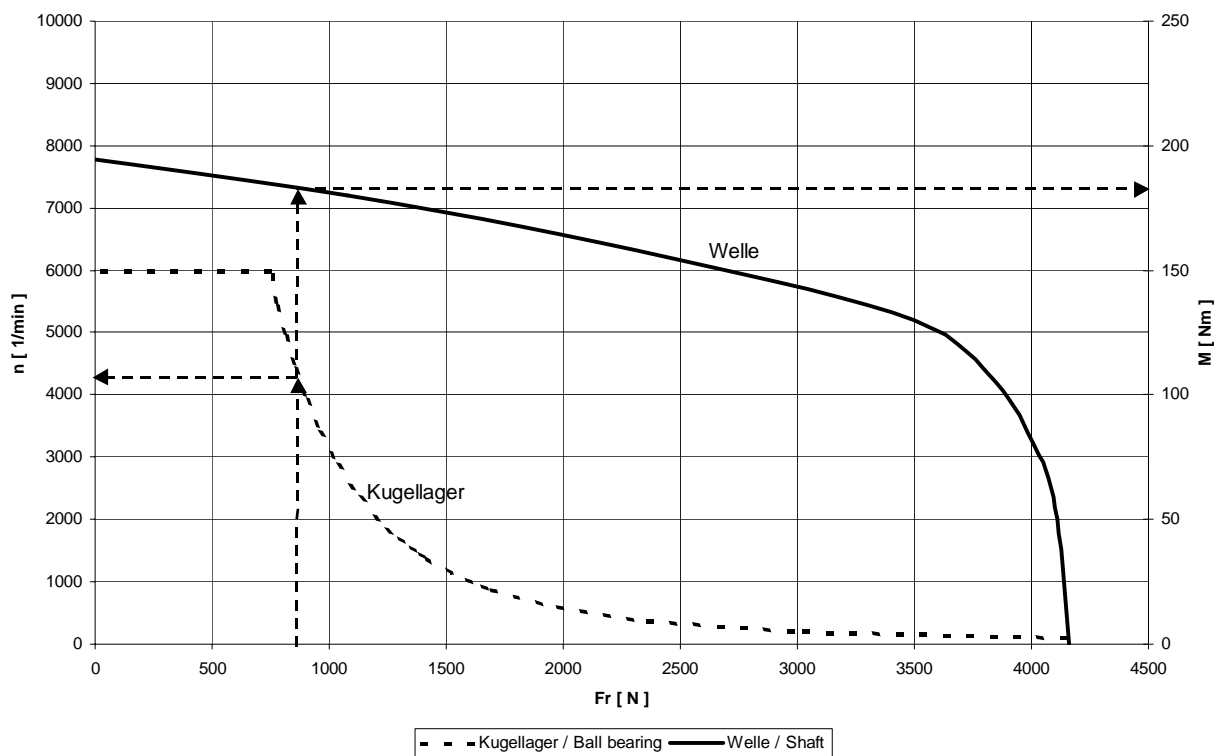

### Explanation of the example

The radial force  $F_r$  of the application is used to determine the possible maximum speed of the bearing in the "Ball bearing" characteristic.

Radial force 850 N => maximum speed 4250 min<sup>-1</sup>

The maximum transmittable torque results from the "Shaft" characteristic.

Radial force 850 N => maximum transmittable torque 185 Nm

DS in standard version or with fan

DS 36

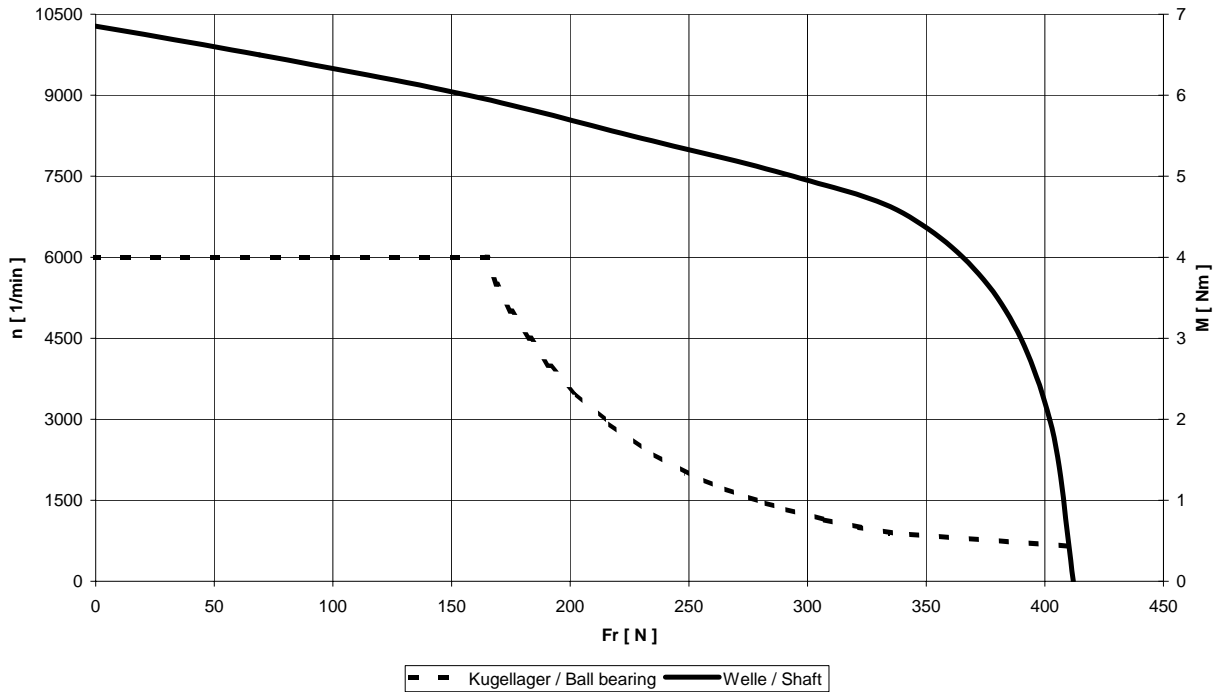

DS 45

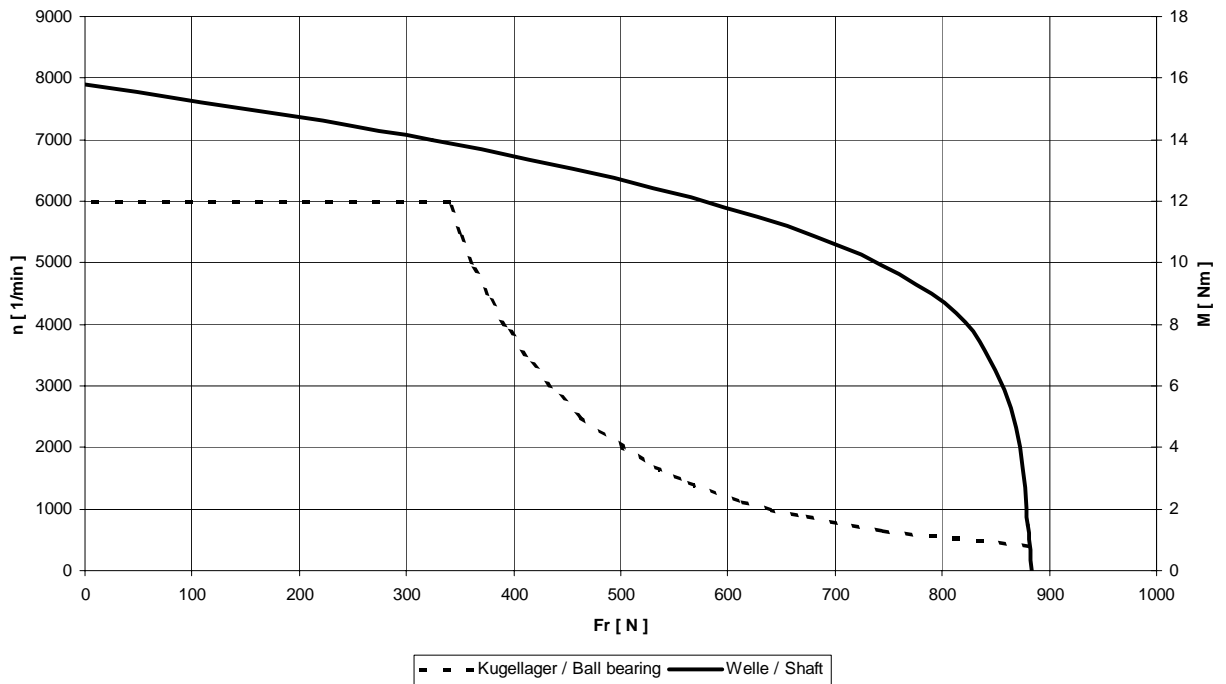

DS 56

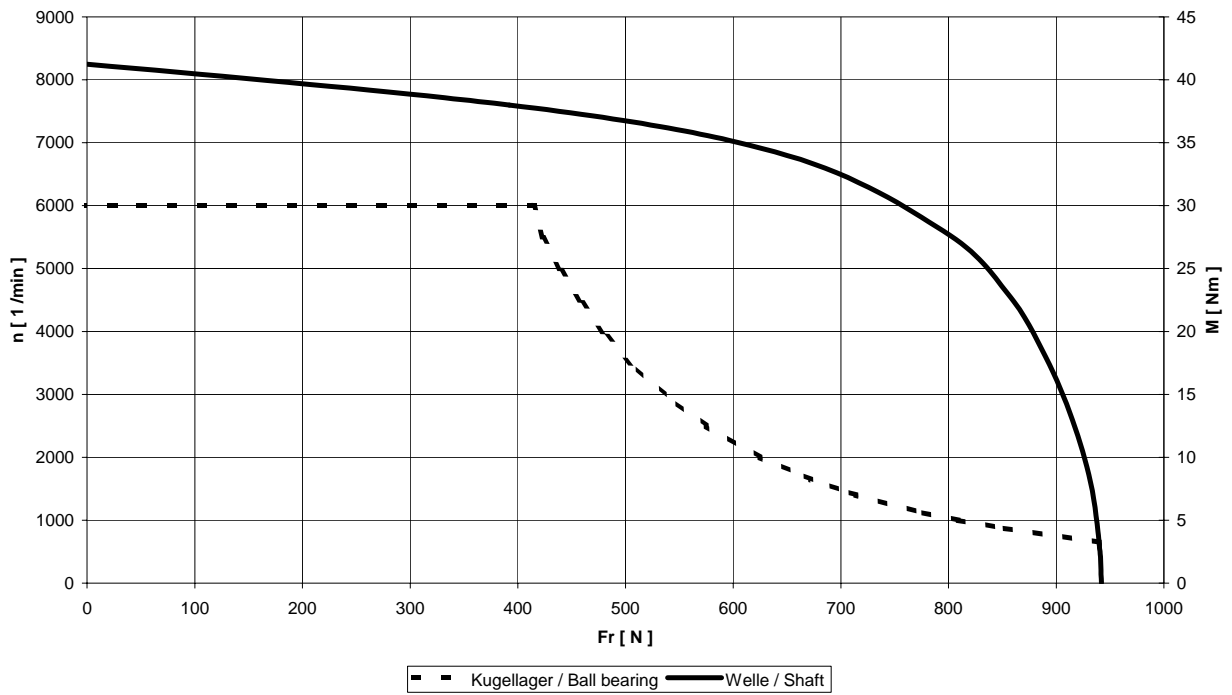

DS 71

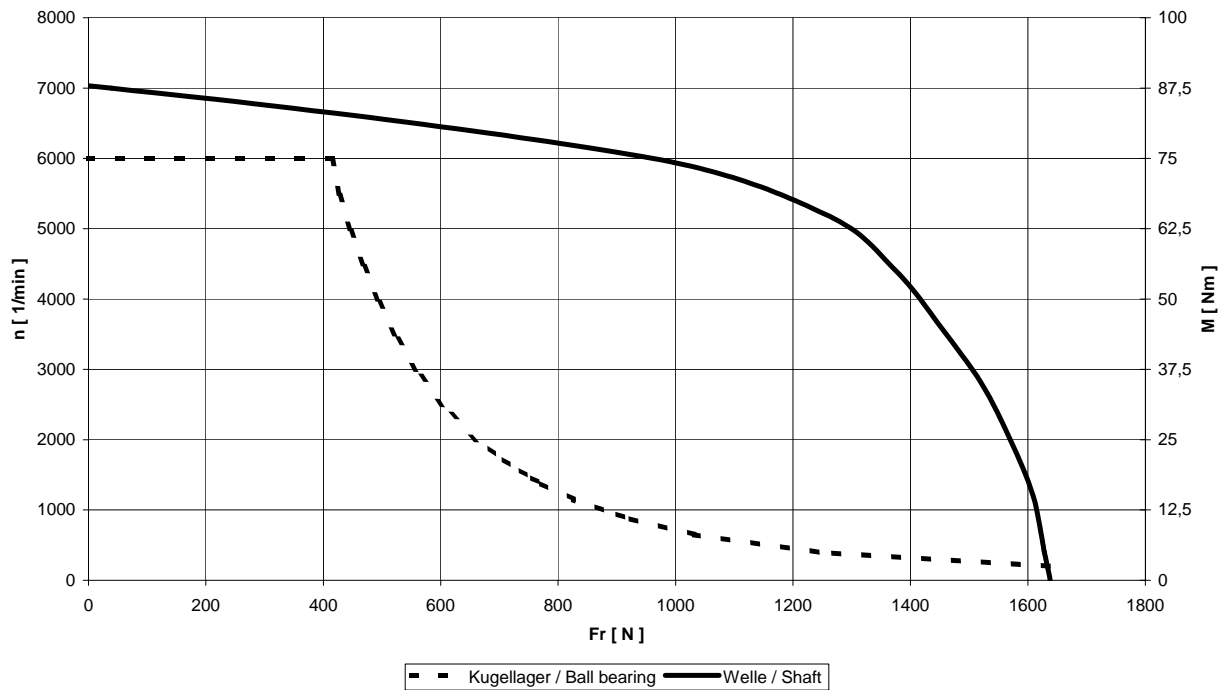

DS 100

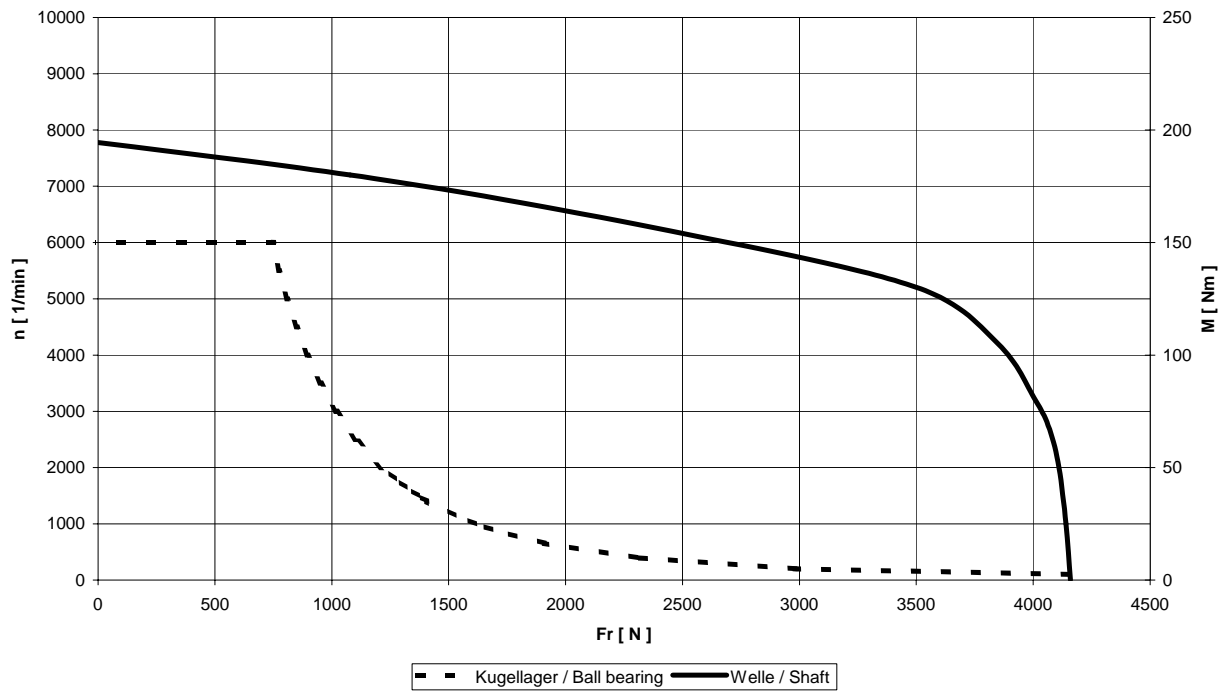

DS in short version

DS 56 (Kurz / Short)

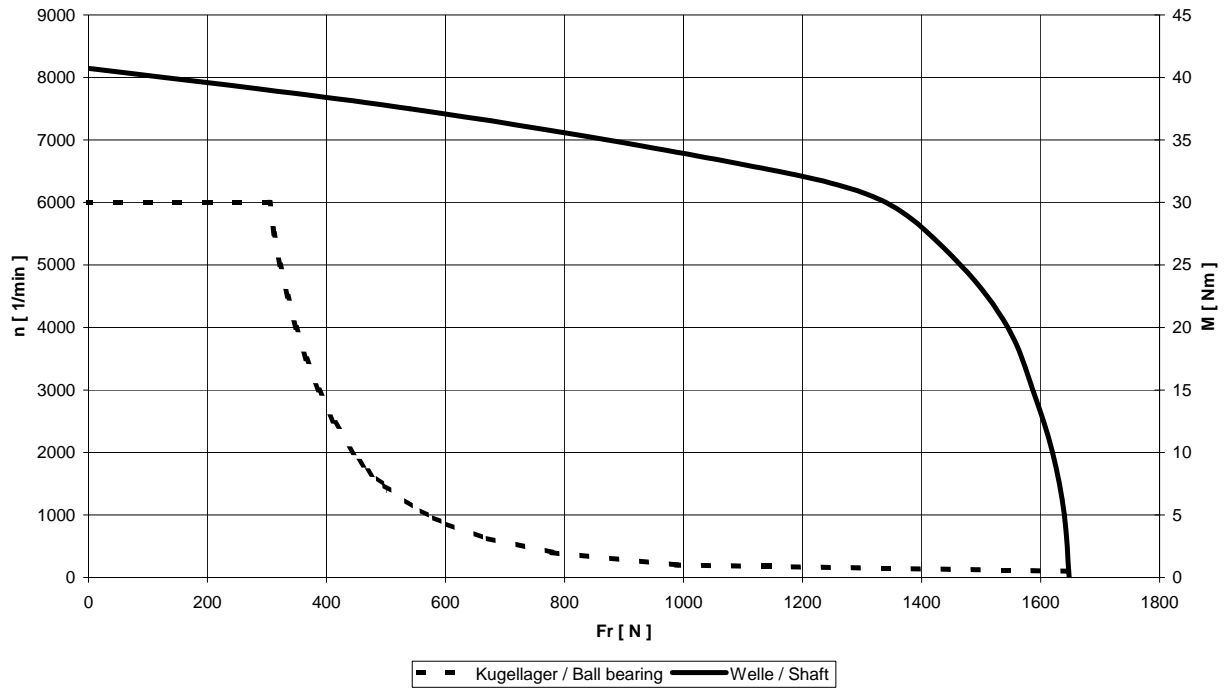

DS 71 (Kurz / Short)

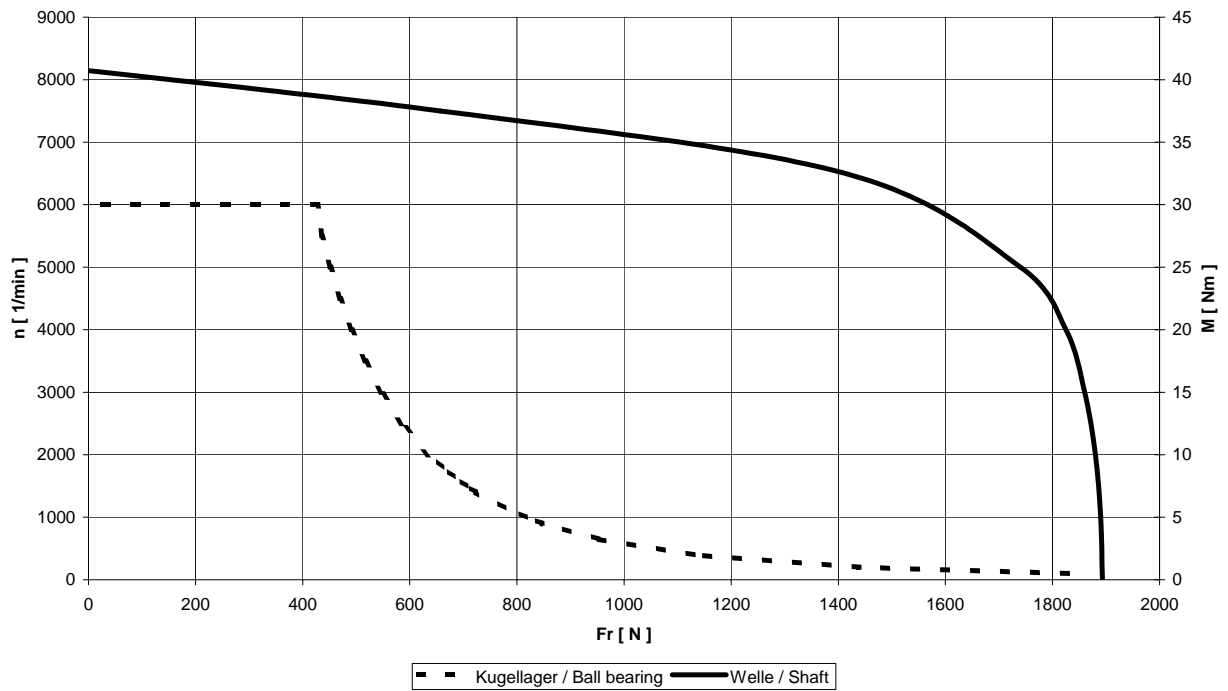

DS 100 (Kurz / Short)

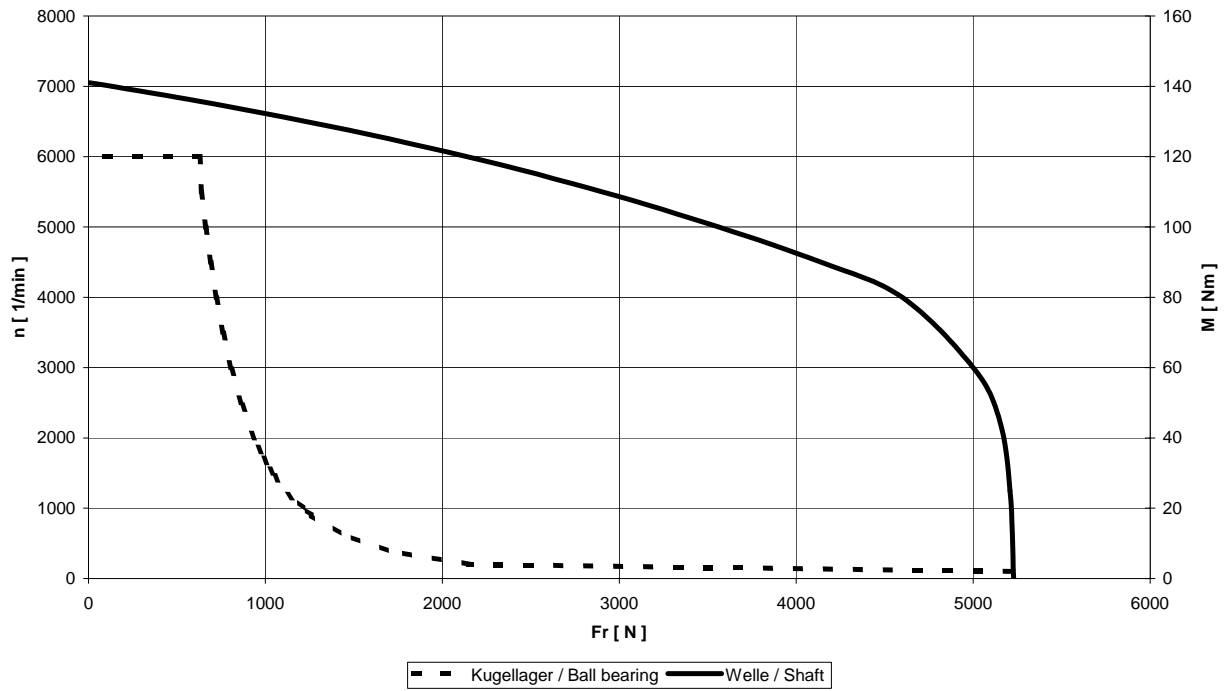

## Main connection – terminal marking and connector assignment

### Main connection via terminal box

The thermal sensor for the resolver is connected via the encoder cable.

Connection diagram

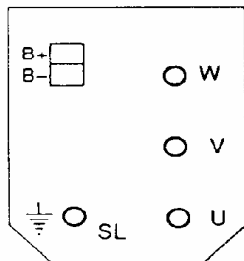

U V W -----Power connection  
 SL -----Protective earth  
 B+ B- -----Brake (option)

Frame size	56	71	100
Stud	M4	M6	M8
metric gland	M20 and M16	M25 and M16	M16 and M40

### Main connection via connector

The connector size is determined by the standstill current  $I_0$  of the motor used. The thermal sensor for the resolver is connected via the encoder cable.

Poles of the female main connectors

		Pin	Signal	Color / marking
Size 1 $I < 15\text{ A}$	<p>The diagram shows a circular female connector with seven pins. Pin 1 is at the bottom left, pin 3 at the bottom right, and pin 4 in the center. Pins A, B, and C are arranged in an arc at the top. Pin D is at the top right. A ground symbol is at the bottom center.</p>	1 ⏏ 3 4 A B C D	Phase U PE Phase V Phase W B+ B-	U green / yellow V V W W W red black white yellow
Size 1.5 $I < 50\text{ A}$	<p>The diagram shows a circular female connector with seven pins. Pin U is at the top, pin V at the top left, and pin W at the top right. Pin PE is in the center, pin B+ at the bottom left, and pin B- at the bottom right. A ground symbol is at the bottom center.</p>	U V W ⏏ + - 1 2	Phase U Phase V Phase W PE B+ B-	U V V W W W green / yellow red black white yellow

View to contact side of female connector

### Thermal sensor

On resolver use, the temperature sensor is connected via the encoder plug. For SinCos encoder use, connection is effected via the main connection.

### KTY84 - 130

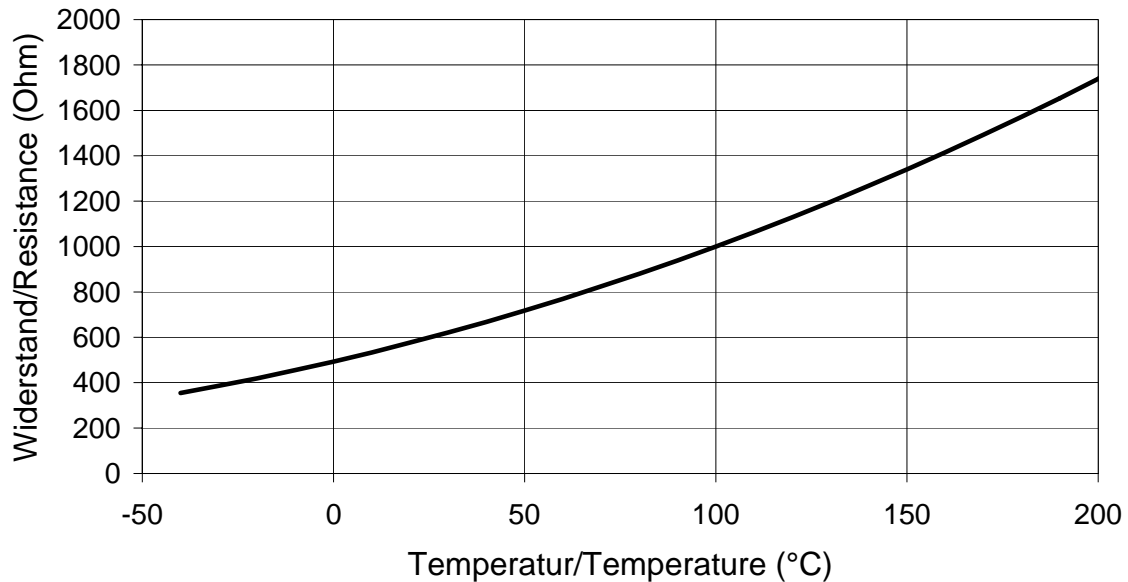

The motor temperature is continuously monitored using the thermal sensor type KTY 84-130. The above shown resistance results when the sensor is supplied with a measuring current of 2 mA.

### Fan data

Fan for type	DSO 56	4656 ZW - 956	230V. 50/60Hz; 0.12A
		4606 ZW - 958	115V. 60 Hz
Fan for type	DSO/ 71 and DSO/LIO 100	148VK028172	230V. 50/60Hz; 0.2A
		148VK028272	115V. 50/60Hz; 0.3A
Type of protection	IP54		
Connection	6-pin connector		

### Fan connection

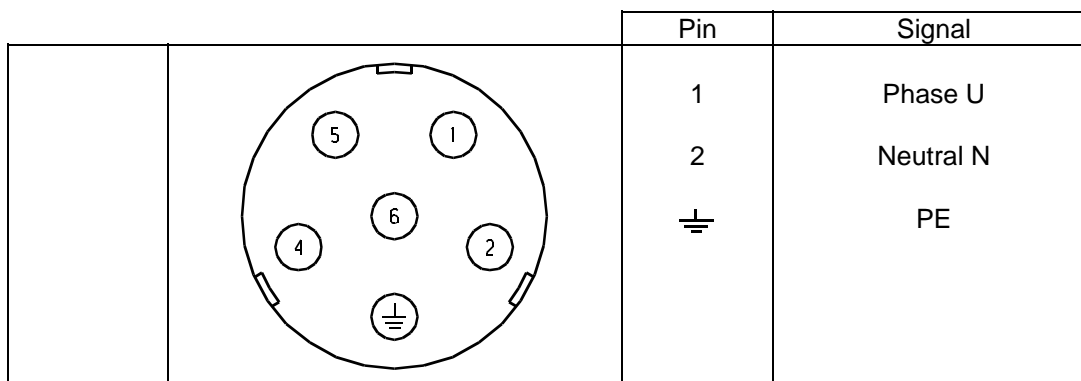

View to contact side of female connector

## Brake assignment

The motors are optionally equipped with a holding brake. The brake uses the normally-on principle. i.e. the brake engages with the operating voltage is switched off or fails. The brakes are supplied for a switching voltage of 24 VDC +5%-10%.

The motors are available with the following holding brakes:

Motor type	Standard version				Short version		
	DS 45	DS 56	DS 71	DS 100	DS 56	DS 71	DS 100
Holding brake	Pm07	PM09	Pm11	Pm16	Pm06	Pm07	Pm11
Minimum static holding torque [Nm] at 120°C	6.5	12	20	80	2.5	6.5	20
Minimum dynamic torque [Nm] at 120°C	4.5	7.5	13	45	1.3	4.5	13
Max. switching work [Joule] per braking operation from $n = 3000 \text{ min}^{-1}$	260	200	1000	2800	40	260	460
Connection values (+5% -10%)	24 V = 16 W	24 V = 18 W	24 V = 22 W	24 V = 31 W	24 V = 12 W	24 V = 16 W	24 V = 22 W
Inertia [kgcm <sup>2</sup> ]	1.06	3.6	7.6	30	0.8	1.06	9.5
Weight [kg]	0.7	1.1	1.9	3.0	0.3	0.7	1.9
Switching time On Brake released [ms]	40	60	100	130	30	40	70
Off [ms]	20	30	25	50	25	20	30

None of the brakes are **fail-safe brakes** so that the torque may be reduced by interference factors beyond control. In accordance with the case of application, observe the relevant accident prevention guidelines as well as the basic safety and health requirements of Appendix I of the Machinery Directive and the harmonized European Standards.

In the event of emergency stop or voltage failure, approx. 2000 braking operations can be carried out without causing the holding brake to overheat (Condition: maximum external inertia = motor inertia and  $n_{\text{max}}$ , type-related).

**Encoder**

**Resolver**

Pole pair number	1
Ratio	0.5
Frequency	5 kHz
Nominal input voltage	4 V
Active input power for no-load operation	112 mW
Current consumption for no-load operation	40 mA
Max. output voltage for no-load operation	2 V eff
Voltage constant	-
Rotor resistance	44 Ω ± 10%
Stator resistance	28 Ω ± 10%
Rotor impedance for no-load operation	70 + j 74 Ω ± 15%
Rotor impedance at short-circuit	62 + j 66 Ω ± 15%
Stator impedance for no-load operation with min. coupling	108 + j 206 Ω ± 15%
Stator impedance at short-circuit and maximum coupling	97 + j 183 Ω ± 15%
Phase shift	8°
Zero voltage	15 mV / °
Phase error referred to zero position	10'

**Resolver connection**

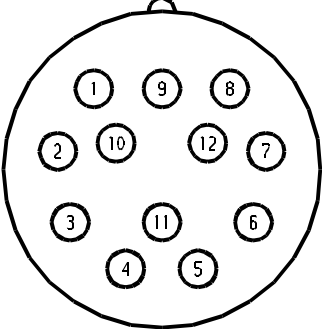
	Pin	Signal
	1	cos -
	2	
	3	
	4	
	5	sin -
	6	sin +
	7	TM -
	8	cos +
	9	TM +
	10	Ref +
	11	
	12	Ref -

View to contact side of female connector

**SINCOS SRS/SRM 50 (Stegmann)**

	SRS 50 / SRM 50
Number of sine. cosine periods per revolution	1024
Number of increments per revolution	32768
Number of absolute resolved revolutions	1      4096
Code type for the absolute value	Binary
Output frequency of sine. cosine signals (kHz)	0 ... 200
Error limits when evaluating 1024 signals. integral non-linearity (arc seconds)	+/- 45
Non-linearity within a sine. cosine period; differential non-linearity (arc seconds)	+/- 7
Working speed up to which the absolute position can be formed (1/min)	6000
Maximum operating speed (1/min)	12000
Output signals; 2 x 90° shifted sinusoidal signals ( $V_{pp}$ )	1
Output signal	serial RS 485. asynchronous. halfduplex
Operating voltage range (V)	7 ... 12
Operating current without load (mA)	80

**SRS/SRM 50 connection**

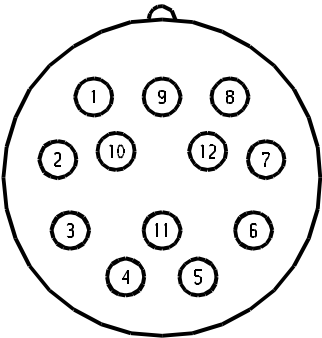
	Pin	Signal
	1	ref cos
	2	+ 485
	3	-
	4	-
	5	sin
	6	ref sin
	7	- 485
	8	cos
	9	-
	10	Gnd
	11	-
	12	+ U

View to contact side of female connector

We recommend not to use optical encoders for motors with a vibration resistance of more than 3g.

**DS 56 / 71 / 100 standard version.**  
**main connection with terminal box**

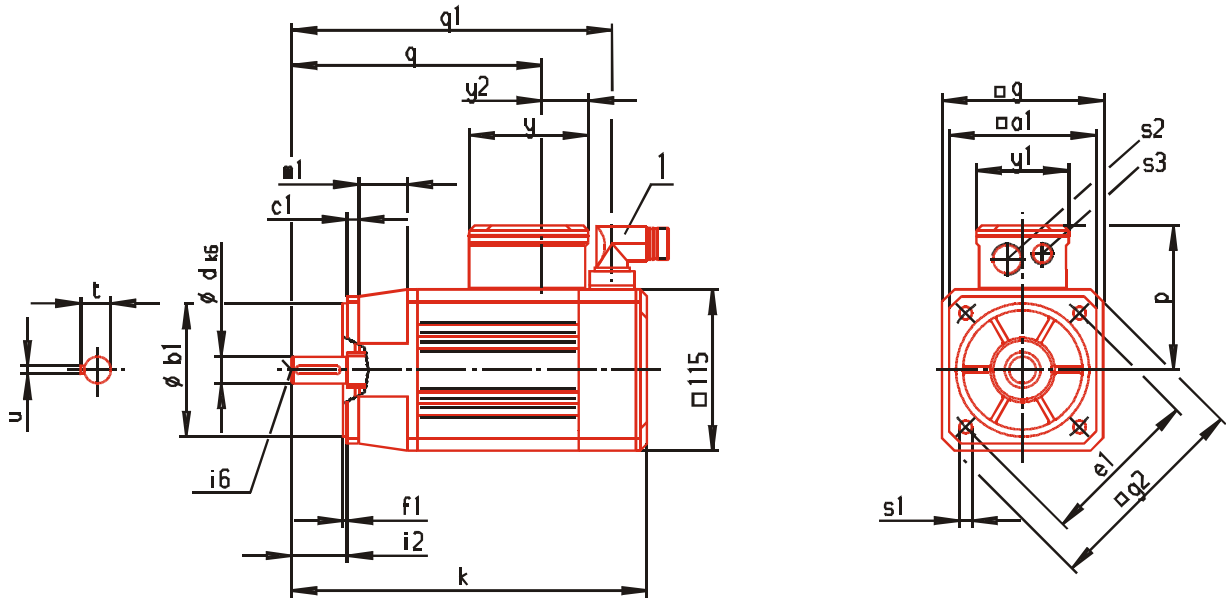

i6 = Centring with internal thread acc. to DIN 332 form D  
 1 = Encoder connector

- DC link voltage of 540 V motors
- Key: Motors are also available without keyway.
- Brake: When a brake is mounted the dimensions remain unchanged.
- IP 65 type of protection is ensured with mounted connectors only.
- Shaft gland protection type is IP64

Type	Flange			Shaft							Motor												
	a1	b1	c1	e1	f1	i2	s1	d	t	u	g2	g	k	m1	p	q	q1	s2	s3	y	y1	y2	
56 S	105	95	8	115	3	40	9	19	21.5	6	150	115	255**	29	103	179	229	M20	M16	85	66	33	
56 M													295**			219	269						
56 L													335**			259	309						
56 *	120	110	9	130	3.5	40	9						28										
71 K	142	130	12	165	3.5	50	12	24	27	8	186	142	316**	32	129	238	290	M25	M16	110	70	35	
71 S													366**			288	340						
71 M													416**			338	390						
100 K	190	180	13	215	4	58	14	32	35	10	250	190	367**	45	174	287	341	M16	M40	150	135	37	
100 S													415**			335	389						
100 M													463**			383	437						
100 L													511**			431	485						

\* The flange of frame size 56 is also available with dimension a1 = 120 mm as a standard. Order in plain text.

\*\* for sincos encoder SCS/SCM k + 20 mm; SRS/SRM k + 30 mm

Version IM B5	Type of protection IP 65	Cooling method IC 0041	
---------------	--------------------------	------------------------	--

DS 45 / 56 / 71 / 100 standard version.  
main connection with connector

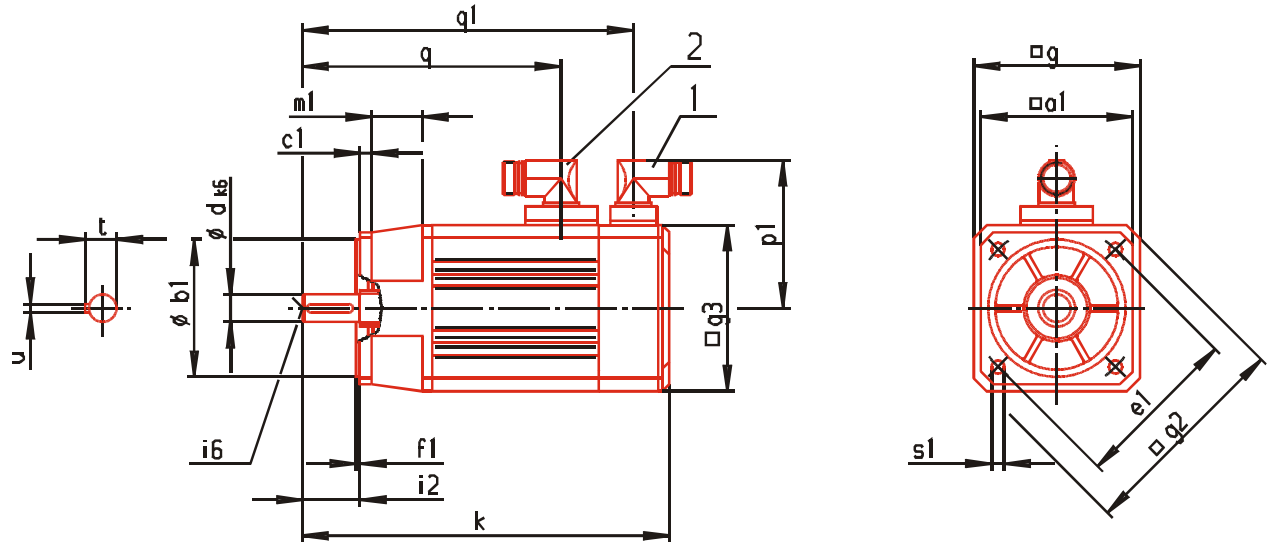

- i6 = Centring with internal thread acc. to DIN 332 form D
- 1 = Encoder connector
- 2 = Connector for main connection/brake (use only up to 44 A)

- DC link voltage of 540 V motors
- Key: Motors are also available without key.
- Brake: When a brake is mounted the dimensions remain unchanged.
- IP 65 type of protection is ensured with mounted connectors only.
- Shaft gland protection type is IP64

Type	Flange			e1	f1	i2	s1	Shaft			Motor											
	a1	b1	c1					d	t	u	g2	g	g3	k	m1	p1	q	q1	q2	y	y1	y2
45 S	90	80	8	100	3	30	7	14	16	5	121	90	90*	192*	27	82	142	175	-	-	-	-
45 M														217*			167	200				
45 L														267*			217	250				
56 S	105	95	8	115	3	40	9	19	21.5	6	150	115	115	255**	29	100	179	229	-	-	-	-
56 M														295**			219	269				
56 L														335**			259	309				
56 ***	120	110	9	130	3.5	40	9								28							
71 K	142	130	12	165	3.5	50	12	24	27	8	186	142	115	316**	32	100	238	290	-	-	-	-
71 S														366**			288	340				
71 M														416**			338	390				
100 K	190	180	13	215	4	58	14	32	35	10	250	190	115	367**	45	100	287	341	-	-	-	-
100 S														415**			335	389				
100 M														463**			383	437				
100 L														511**			431	485				

\* for sincos encoder SCS/SCM g3 + 9 mm and k + 33 mm; SRS/SRM g3 + 9 mm and k + 35 mm

\*\* for sincos encoder SCS/SCM k + 20 mm; SRS/SRM k + 30 mm

\*\*\* The flange of frame size 56 is also available with dimension a1 = 120 mm as a standard. Order in plain text.

Version IM B5	Type of protection IP 65	Cooling method IC 0041	70599207
---------------	--------------------------	------------------------	----------

**DS 56 / 71 / 100 standard version with fan.  
main connection with terminal box**

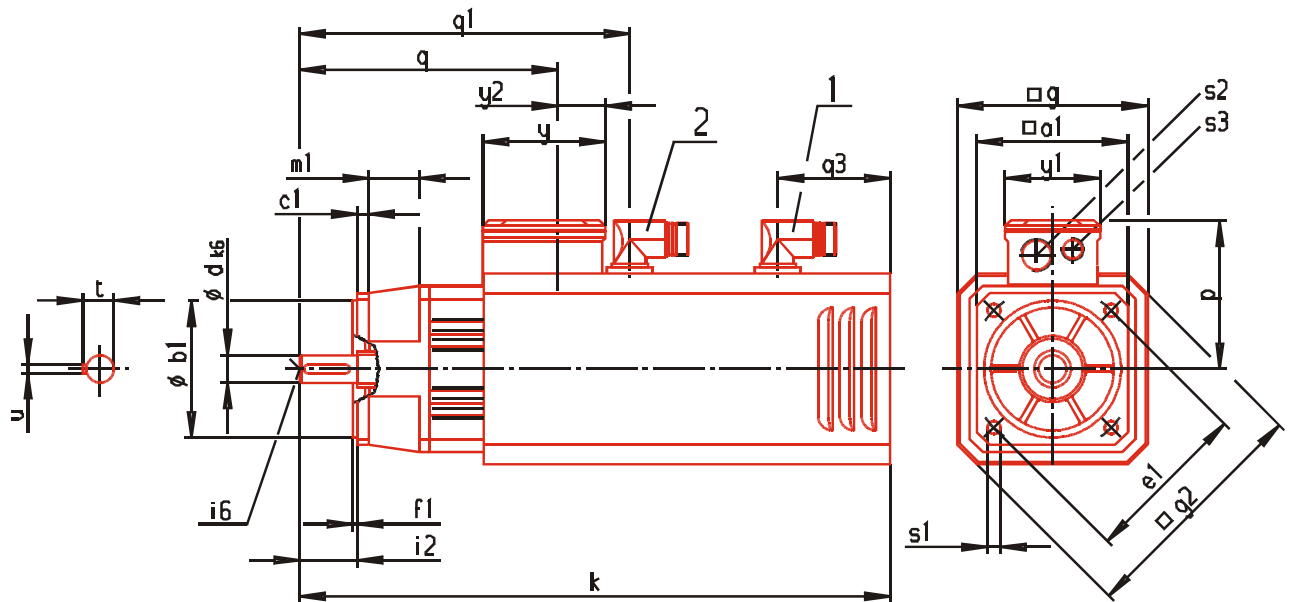

i6 = Centring with internal thread acc. to DIN 332 form D

1 = Fan connector

2 = Encoder connector

- DC link voltage of 540 V motors
- Key: Motors are also available without key
- Brake: When a brake is mounted the dimensions remain unchanged.
- IP 54 type of protection is ensured with mounted connectors only.
- Shaft gland protection type is IP64

Type	Flange			e1	f1	i2	s1	Shaft			Motor												
	a1	b1	c1					d	t	u	g2	g	k	m1	p	q	q1	q3	y	y1	y2	s2	s3
56 S	105	95	8	115	3	40	9	19	21.5	6	167	132	411	29	103	179	229	78	85	66	33	M20	M16
56 M													451			219	269						
56 L													491			259	309						
56 *	120	110	9	130	3.5	40	9							28									
71 K	142	130	12	165	3.5	50	12	24	27	8	218	180	503	32	129	238	290	90	110	70	35	M25	M16
71 S													553			288	340						
71 M													603			338	390						
100 K	190	180	13	215	4	58	14	32	35	10	270	210	576	45	174	287	341	115	150	135	37	M16	M40
100 S													624			335	389						
100 M													672			383	437						
100 L													720			431	485						

\* The flange of frame size 56 is also available with dimension a1 = 120 mm as a standard. Order in plain text.

Version IM B5	Type of protection IP 54	Cooling method IC 0641	70599208
---------------	--------------------------	------------------------	----------



**DS 56 / 71 / 100 short version.**  
**main connection with terminal box**

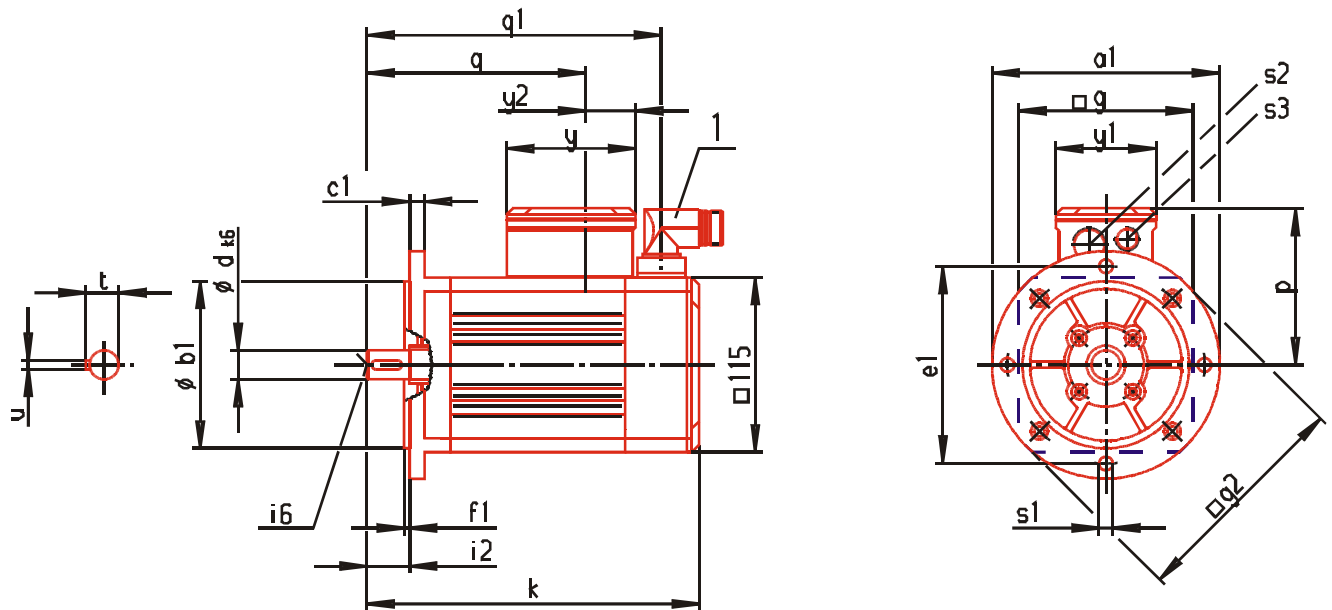

i6 = Centring with internal thread acc. to DIN 332 form D  
 1 = Encoder connector

- DC link voltage of 540 V motors
- Key: Motors are also available without key
- Brake: When a brake is mounted the dimensions remain unchanged.
- IP 65 type of protection is ensured with mounted connectors only.
- Shaft gland protection type is IP64

Type	Flange			Shaft							Motor											
	a1	b1	c1	e1	f1	i2	s1	d	t	u	g2	g	k	m1	p	q	q1	s2	s3	y	y1	y2
56 A	150	110	10	130	3.5	28	9	19	21.5	6	150	115	199*	-	103	124	174	M20	M16	85	66	33
56 B													219*			144	194					
71 B	186	130	10	165	3.5	28	11	19	21.5	6	186	142	234*	-	129	157	209	M25	M16	110	70	35
71 C													259*			182	234					
100 B	250	180	13	215	4	42	14	28	31	8	250	190	266*	-	174	186	240	M16	M40	150	135	37
100 C													290*			210	264					
100 D													314*			234	288					

\* for sincos encoder SCS/SCM k + 20 mm; SRS/SRM k + 30 mm

Version IM B5	Type of protection IP 65	Cooling method IC 0041	
---------------	--------------------------	------------------------	--

DS 56 / 71 / 100 short version.  
main connection with connector

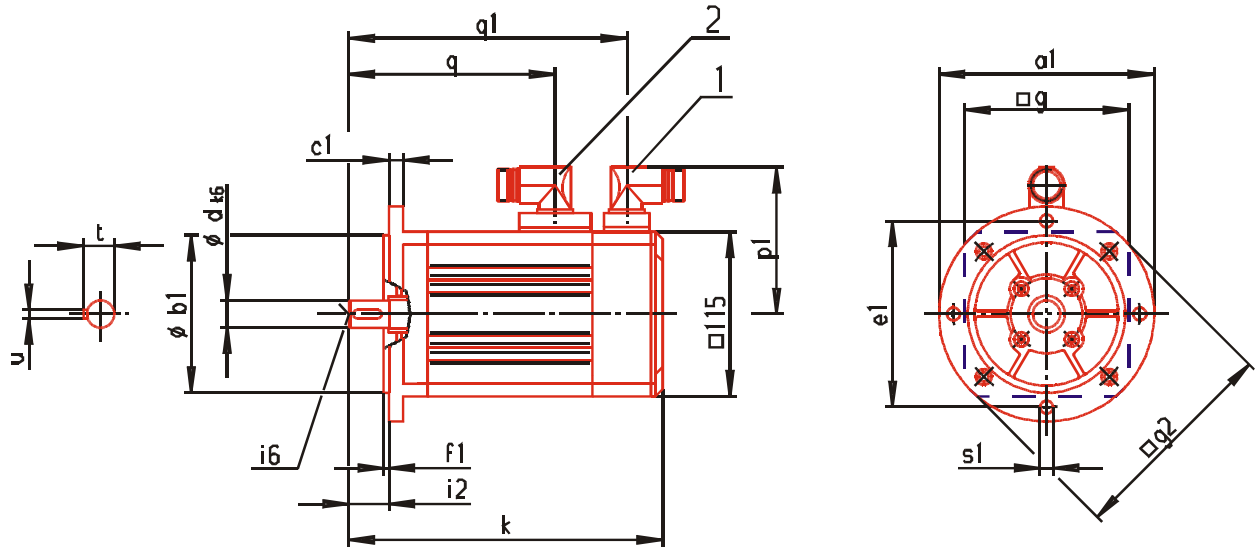

i6 = Centring with internal thread acc. to DIN 332 form D

1 = Encoder connector

2 = Main connection/brake

- DC link voltage of 540 V motors
- Key: Motors are also available without key
- Brake: When a brake is mounted the dimensions remain unchanged.
- IP 65 type of protection is ensured with mounted connectors only.
- Shaft gland protection type is IP64

Type	Flange			Shaft							Motor											
	a1	b1	c1	e1	f1	i2	s1	d	t	u	g2	g	k	m1	p1	q	q1	q2	q3	y	y1	y2
56 A	150	110	10	130	3.5	28	9	19	21.5	6	150	115	199*	-	100	124	174	-	-	-	-	-
56 B													219*			144	194					
71 B	186	130	10	165	3.5	28	11	19	21.5	6	186	142	234*	-	100	157	209	-	-	-	-	-
71 C													259*			182	234					
100 B	250	180	13	215	4	42	14	28	31	8	250	190	266*	-	100	186	240	-	-	-	-	-
100 C													290*			210	264					
100 D													314*			234	288					

\* for Sincos encoder SCS/SCM k + 20 mm; SRS/SRM k + 30 mm

Version IM B5	Type of protection IP 65	Cooling method IC 0041	70599211
---------------	--------------------------	------------------------	----------

**Main connection. fan and male and female encoder connectors**

Female flange connector main connection (size 1 for current  $I_0$  to 15 A). fan and encoder

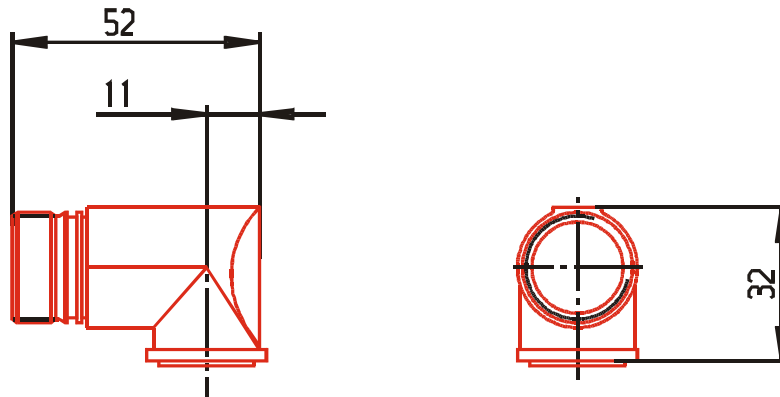

Main connector (size 1 for current  $I_0$  to 15 A) and fan

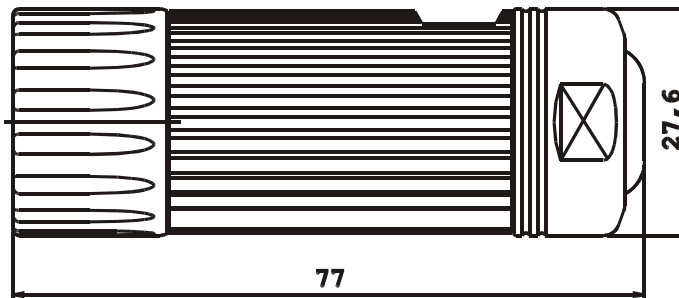

Encoder connector

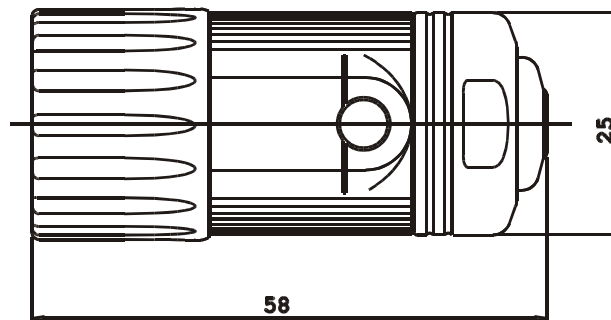

Female flange connector main connection (size 1.5 for current  $I_0$  to 50 A)

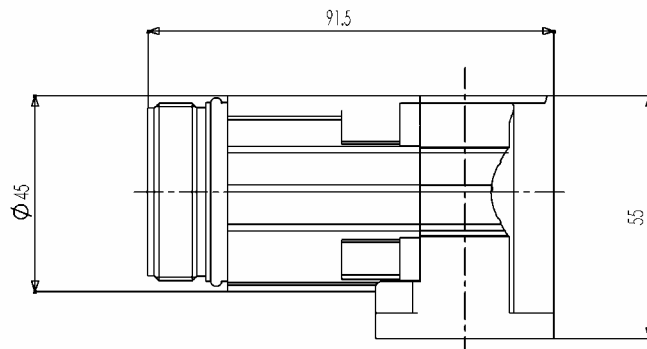

Main connector (size 1.5 for current  $I_0$  to 50 A)

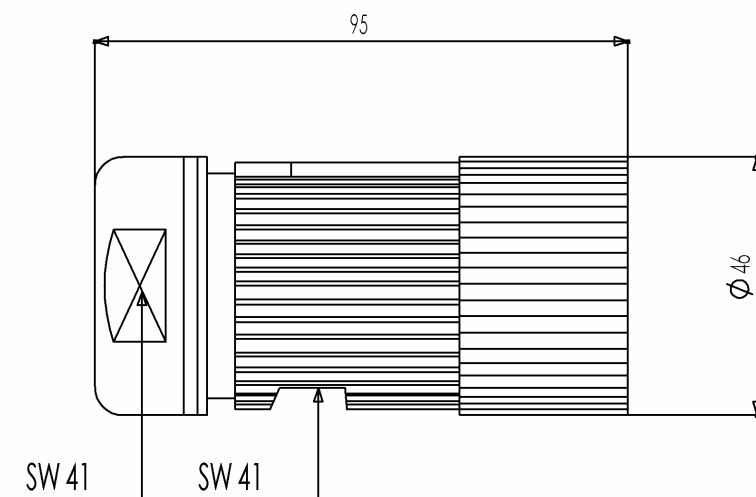

## Motor cables

### General

The motor cables are highly flexible trailing cables with overall shielding. They comply with the regulations VDE, UL and CSA.

The control cables are integrated as star-quads. When the sincos encoder is used the brake triggering and the connection of the thermal sensor are brought out via the main connector.

The cables are particularly suitable for the optimum use of cable racks thanks to their low cross-section, low weight and non-impeding surface. They can thus be efficiently used in trailing chains.

The overall shielding with an optical coverage of more than 85% makes it an EMC uncritical cable.

The connector size is designed in accordance with the motor's standstill current  $I_0$ .

### Technical data

#### Technical description

- Sheath resistance against media such as coolants, machine and gearbox oils
- Abrasion resistance because of a special surface in cable racks and trailing chains
- High-flexible, trailing cable
- Sheath surface not blocking, satin-finish
- Shield made of tinned copper braid with optical coverage of  $\geq 85\%$
- Core insulation made of TPE or polyester, sheath material PUR halogene-free
- Cable FCF-free and silicone-free
- Behavior in case of fire: fire-inhibiting, halogene-free
- Cable color in RAL 1028, melon yellow
- Labelling with Baumüller sign, VDE, UL and CSA sign
- Minimum bending radius for flexible use  $12 \times D$

#### Nominal voltage

U<sub>0</sub>/U 600 / 1000 V (power cores)

U 24 V DC (control cores)

#### Core lettering

Power cores U, VV, WWW

Colored control cable pairs as star-quads in red, white, black, yellow

Assignment of pairs red – black (brake).

white – yellow (temperature)

#### Cable data

Cable cross-section	Nominal current [A] <sup>1)</sup>	Cable diameter [mm]
4×1.5 mm <sup>2</sup> 4×0.75 mm <sup>2</sup>	15	11.7 – 12.3
4×2.5 mm <sup>2</sup> 4×0.75 mm <sup>2</sup>	21	12.7 – 14.6
4×4 mm <sup>2</sup> 4×0.75 mm <sup>2</sup>	28	14.2 – 15.4
4×6 mm <sup>2</sup> 4×0.75 mm <sup>2</sup>	36	16.6 – 17.9
4×10 mm <sup>2</sup> 4×0.75 mm <sup>2</sup>	50	20.5 – 21.5
4×16 mm <sup>2</sup> 4×0.75 mm <sup>2</sup>	66	23.0 – 25.8
4×25 mm <sup>2</sup> 2×(2×1.5 mm <sup>2</sup> )	84	26.3 – 29.7
4×35 mm <sup>2</sup> 2×(2×1.5 mm <sup>2</sup> )	104	30.8 – 32.5

- 1) Current carrying capacity acc. to table 5 laying type C or E  
(VDE 0113 / EN 60 204 Part 1 issue 1997)  
Ambient temperature 40°C

**Cable – connector assignment**

Cable cross-sections	Nominal current [A]	Male connector 540 V Size
4×1.5 mm <sup>2</sup> 4×0.75 mm <sup>2</sup>	15	1
4×2.5 mm <sup>2</sup> 4×0.75 mm <sup>2</sup>	21	1.5
4×4 mm <sup>2</sup> 4×0.75 mm <sup>2</sup>	28	1.5
4×6 mm <sup>2</sup> 4×0.75 mm <sup>2</sup>	36	1.5
4×10 mm <sup>2</sup> 4×0.75 mm <sup>2</sup>	50	1.5

The connectors must be designed with respect to the  $I_0$  motor current. For the laying of the cables, the current carrying capacity acc. to table 5 laying type C or E (VDE 0113 / EN 60 204 Part 1 issue 1997) and an ambient temperature of 40°C must be considered.

Cables of 2.5 mm<sup>2</sup> can be laid up to 100 m without additional filters, when larger cross-sections used, up to 40 m are permissible. The terminal voltage at the motor must be < 1kV. When longer cables are used, filters must be installed between converter and motor.

**Application notes****Operating temperature**

The cables can be operated within a temperature range from –20°C to +80°C.

**Cable laying at the motor**

The cables must not touch the motor surface.

**Smallest permissible bending radii**

12 times outer cable diameter.

Smaller bending radii are possible with reduced service life.

## Main connection cables / Assembled cable with connector

### Nominal current: 15 A

Cable 4 x 1.5 mm<sup>2</sup> + 4x 0.75 mm<sup>2</sup>  
with connector Size1

Length in m	Article no.
5	324781
7	324782
10	324783
15	324784
20	324785
25	324786
30	324787
35	324788
40	324789
50	324790
75	324791
100	324792

### Nominal current: 36 A

Cable 4 x 6 mm<sup>2</sup> + 4x 0.75 mm<sup>2</sup>  
with connector Size1.5

Length in m	Article no.
5	326600
7	326601
10	326602
15	326603
20	326604
25	326605
30	326606
35	326607
40	326608

### Nominal current: 21 A

Cable 4 x 2.5 mm<sup>2</sup> + 4x 0.75 mm<sup>2</sup>  
with connector Size1.5

Length in m	Article no.
5	326577
7	326578
10	326579
15	326580
20	326581
25	326582
30	326583
35	326584
40	326585
50	326586
75	326587
100	326588

### Nominal current: 50 A

Cable 4 x 10 mm<sup>2</sup> + 4x 0.75 mm<sup>2</sup>  
with connector Size1.5

Length in m	Article no.
5	326609
7	326610
10	326611
15	326612
20	326613
25	326614
30	326615
35	326616
40	326617

### Nominal current: 28 A

Cable 4 x 4 mm<sup>2</sup> + 4x 0.75 mm<sup>2</sup>  
with connector Size1.5

Length in m	Article no.
5	326589
7	326591
10	326592
15	326593
20	326594
25	326596
30	326597
35	326598
40	326599

### Connector

Type	Article no.
Size 1 f. 4x1.5mm <sup>2</sup>	261740
Size 1.5 f. 4x2.5mm <sup>2</sup> o. 4mm <sup>2</sup>	326574
Size 1.5 f. 4x6mm <sup>2</sup> o.10mm <sup>2</sup>	326569

Larger cable cross-sections on request.

Longer cables can also be used. The terminal voltage at the motor must be < 1kV. In this case, however, filters must be installed between converter and motor.

## Encoder cables

### General

A fully preassembled encoder cable is used for all encoder systems. Motor connection is via a 12-pin round signal connector and converter connection via a 15-pin sub-D plug. The encoder cables are available as 'trailing' and 'non-trailing' cables. The trailing cable is suitable for use in trailing chains, for example. As opposed to the 'non-trailing' cable, the cable sheath consists of tougher PUR for use in environments with acids and bases (coolants) instead of PVC. Up to a length of 10 m, the cables are available in 1 m sections (1 m, 2 m, 10 m). From a cable length of 10 m, the sections come in 5 m intervals (10 m, 15 m, ...).

In the case of servo motors, the resolver encoder system links the temperature sensor with the converter via the encoder cable.

### Technical data

#### 1. Technical description – non-trailing

- LiYCY. 5x (2x0.14mm<sup>2</sup>) + 2 x 0.5mm<sup>2</sup> copper lead, twisted pair
- PVC sheath, grey
- 1<sup>st</sup> end: 12-pin signal circular connector with 12 female contacts
- 2<sup>nd</sup> end: 15-pin D-Sub connector with male contacts and locking screws 4-4OUNC
- Baumüller labelling, black
- Outer diameter 9.0 mm (+/-3mm)
- Bending radius:  $r \geq 60$  mm (fixed installation),  $r \geq 135$  mm (flexible use)
- Nominal voltage: 250V<sub>AC</sub>

#### 2. Technical description – trailing

- Li12YC11Y. 5x (2x0.14mm<sup>2</sup>) + 2 x 0.5mm<sup>2</sup> copper lead, twisted pair
- PU sheath, black
- 1<sup>st</sup> end: 12-pin signal circular connector with 12 female contacts
- 2<sup>nd</sup> end: 15-pin D-Sub connector with male contacts and locking screws 4-4OUNC
- Baumüller labelling, white
- Outer diameter 9.0 mm (+/-3mm)
- Bending radius:  $r \geq 70$  mm (fixed installation),  $r \geq 100$  mm (flexible use)
- Nominal voltage: 300V<sub>AC</sub>

**Application notes**

- Operating temperature

	trailing	non-trailing
Limit temperature	at the surface	at the surface
no / few movements	-40 °C to +80 °C	- 30 °C to +80 °C
continuous movements	- 30 °C to +80 °C	-5 °C to + 70 °C

- Cable laying at the motor

The cables must not touch the motor surface.

**Ordering data**

Encoder cables / preassembled cables with connector

**Encoder cable**

**non-trailing.  
assembled**

Cable 5 x (2x014mm<sup>2</sup>) + 2 x 0.5 mm<sup>2</sup> with connector

Length in m	Article no.
1	243601
2	211338
3	219333
4	231166
5	209879
6	220197
7	216455
8	220429
10	210052
15	215716
20	218568
25	218569
30	217094
35	216444
40	217095
45	217567
50	217568
55	217569
60	217570
70	232088

**trailing.  
assembled**

Cable 5 x (2x014mm<sup>2</sup>) + 2 x 0.5 mm<sup>2</sup> with connector

Length in m	Article no.
3	246658
4	243379
5	239540
6	242954
8	239541
10	239542
15	239543
20	239544
25	239545
30	239546
35	239547
40	240520
45	240521
50	240522
55	244033
60	245484

Encoder connector	Article no.
Encoder connector	201833

**Commissioning and maintenance instructions**

Please contact us for our commissioning and maintenance instructions for motor commissioning.







## Drive Center National

### Darmstadt

**Baumüller Nürnberg GmbH**  
Waldstraße 1 • D-64347 Griesheim  
Tel +49- (0)6155 8430-00 • Fax +49- (0)6155 8430-20

### Düsseldorf

**Baumüller Nürnberg GmbH**  
Jacob-Kaiser-Str. 7 • D-47877 Willich-Münchheide  
Tel +49- (0)2154-487-0 • Fax +49- (0)2154-487-59

### Dresden

**Baumüller Kamenz GmbH**  
Nordstraße 57 • D-01917 Kamenz  
Tel +49- (0)3578 3406-0 • Fax +49- (0)3578 3406-50

### Hannover

**Baumüller Nürnberg GmbH**  
Bohlenweg 10 • D-30853 Langenhagen  
Tel +49-(0)511 771968-0 • Fax +49- (0)511 771968-77

### Nürnberg

**Baumüller Nürnberg GmbH**  
Ostendstr. 80-90 • D-90482 Nürnberg  
Tel +49- (0)911-5432-501 • Fax +49- (0)911-5432-510

### Stuttgart

**Baumüller Nürnberg GmbH**  
Hahnweidstr. 21 • D-73230 Kirchheim / Teck  
Tel +49- (0)7021-48557-10 • Fax +49-(0)7021-48557-77

## Drive Center International

### Australia / Sydney Office

**Baumüller Australia Pty. Ltd.**  
19 Baker Street • Botany NSW 2019 • SYDNEY,  
Tel +61 2 83350-100 • F +61 2 83350-169

### Austria

**Baumüller Austria Ges.m.bH**  
Im Bäckerfeld 17 • A-4060 Leonding  
Tel +43 (0)732 674414-0 • Fax +43 (0)732 674414-32

### England

**Baumüller (UK) Ltd.**  
14 Redlands Centre • GB-Coulsdon, Surrey CR5 2HT  
Tel +44(0)208 76329-90 • Fax +44(0)208 76329-59

### France

**Baumüller France S.à.r.l.**  
Zone de la Malnoue  
39, Avenue de l'Europe • F- 77184 Emerainville  
Tel +33 1 6461-6622 • Fax +33 1 6461-6006

### India

**Baumüller KAT India Pvt. Ltd.**  
Dattaprasad Apartment • Flat No. 7, 3Rd Floor,  
B/7, 1206, APTE Road • IND- 411 004 Pune  
Tel +91 20 25513311 • Fax +91 20 25513388

### Italy

**Baumüller Italia s.r.l.,**  
Viale Italia, 12 • I-20094 Corsico (Mi),  
Tel +39 02 45100-181 • Fax +39 02 45100-426

### Spain

**Baumüller Ibérica S.A.**  
Ausias Marc, 13 1º 2º • E- 08010 Barcelona  
Tel +34 (0)93 34 26 926 • Fax +34 (0)93 27 01 321

### Switzerland

**Baumüller Suisse S.A.**  
Rue des Usines 22 • CH-2000 Neuchâtel  
Tel +41 (0)32 7301-260 • Fax +41 (0)32 7301-351

### The Netherlands

**Baumüller Benelux B.V.**  
Platinastraat 141 • NL-2718 SR Zoetermeer  
Tel +31(0)79-3614-290 • Fax +31(0)79-3614-339

### Turkey

**BAUMÜLLER MOTOR KONTROL SISTEM**  
**SAN. VE TIC. LTD. STI**  
Colak Ismail Sok., No:31/1 • TR-81070 Istanbul-Suadiye  
Tel +90 (0)216 372-2485 • Fax +90 (0)216 372-7570

### USA

**Baumüller Hartford Inc.**  
117 West Dudley Town Road • USA-Bloomfield,  
CT 06002  
Tel +1 860 -243 0232 • Fax +1 860 -286 3080

### USA

**Baumüller Chicago Corp.**  
405 Algonquin Rd. • USA-Mount Prospect, Ill 60056  
Tel +1 847 956-7392 • Fax +1 847 956-7925

## Representatives International

### Brasil

**NC SERVICE INDÚSTRIA E COMÉRCIO LTDA.**  
Av. Juruá, 150, - Barueri - SP • BR- 06455 - 010  
Tel +55 (0)11 4195-0502 • Fax +55 (0)11 4195-2479

### China

**Beijing Yanghai Automation Technology Co., Ltd.**  
Room 1008, No.7, Huaqing Business Building,  
Iluqing Garden, Wudaokou, Haidian  
District, Beijing 100083, P.R.C.  
Tel +86 (0)10 82867980 • Fax +86 (0)10 82867987

### China

**Sunary Automatic Technology Limited Company**  
3<sup>rd</sup> Floor No.476 Chunxiao Rd. Zhangjiang  
High-Tech Park Pudong, Shanghai 201203  
Tel +86 (0)21 50809898 • Fax +86 (0)21 53087675

### Denmark

**Robotek EL & Teknik A/S**  
Blokken 31 Postbox 30 • DK-3460 Birkerød  
Tel +45 4484 7360 • Fax +45 4484 4177

### Iran

**PAK GOSTAR Co.**  
502, 5th Floor, BORJ-E SEFID, PASDARAN Ave  
TEHRAN - IRAN  
Tel +98 21 2553868-70 • Fax + +98 21 2547703

### Korea

**BOMAC SYSTEMS**  
712 Yucheon Factophia • 196 Anyang-7 dong, Mananku,  
Anyangsi. • Kyungkido 430-017, Korea  
Tel +82 31 467-2030 • Fax +82 31 467-2033

### Poland

**Mekelburger Polska**  
Ul. Kościelna 39 F/3 • PL-60537 Poznań  
Tel. / Fax +48 (0)61-8481520

### Russia

**Permanent K&M**  
Wolokolamskoye Chaussee 73 • Office 517  
Moscow, 125424  
Tel +7 (0)95 9563867 • Fax +7 (0)95 7803429

### USA

**Industrial Drives Design, Inc.**  
668 Flinn Avenue Unit 28 • USA- Moorpark  
CA 93021  
Tel +1 805 378-1170 • Fax +1 805 378-1171

### Venezuela, Columbia, Ecuador

**Nimbus International C.A.**  
C.C. Parque Tuy, Local P-18  
YV-Ocumare del Tuy 1209  
Tel +58(0)239-2251347 • Fax +58(0)239-2257149

## Manufacturing locations

### Motors

**Baumüller Nürnberg GmbH**  
Ostendstraße 80- 90 • D-90482 Nürnberg  
Tel +49- (0)911-5432-0 • Fax +49- (0)911-5432-130

### Baumüller Nürnberg GmbH

Werk Kitzingen  
Floßhafenstraße 2 • D-97318 Kitzingen  
Tel +49- (0)9321-70080 • Fax +49- (0)9321-700888

### Baumüller Brno s.r.o.

Skalice nad Svitavou 72  
CZ- 67901 Skalice nad Svitavou,  
Tel +420 516-499 111 • Fax +420 516-499 117

### Baumüller Kamenz GmbH

Nordstraße 57 • D-01917 Kamenz  
Tel +49- (0)3578 3406-0 • Fax +49- (0)3578 3406-50

### Small Motors

**Baumüller Nürnberg GmbH**  
Werk Bad Gandersheim  
Flugplatzweg 2 • D-37581 Bad Gandersheim  
Tel +49- (0)5382 9805-0 • Fax 49- (0)5382 9805-55

### Electronics

**Baumüller Nürnberg GmbH**  
Ostendstraße 80- 90 • D-90482 Nürnberg  
Tel +49- (0)911-5432-293 • Fax +49- (0)911-5432-328

### Baumüller Dravinja d.o.o.

Delavska cesta 10 • SI-3210 Slovenske- Konjice  
Tel +386 3-75723-00 • Fax +386 3-75723-32/33

## Systems

**Baumüller Anlagen-Systemtechnik GmbH & Co. KG**  
Ostendstraße 84 • D-90482 Nürnberg  
Tel +49- (0)911-54408-0 • Fax +49- (0)911-54408-749

## Services

### Baumüller Reparaturwerk GmbH & Co KG

Andernacher Straße 19 • D-90411 Nürnberg  
Tel +49- (0)911-9552-0 • Fax+49- (0)911-9552-999

### München

**Baumüller München GmbH**  
Meglingerstraße 58 • D-81477 München  
Tel +49- (0)89 748898-10 • Fax +49- (0)89 748898-75

**be in motion**

Responsible for content: Baumüller Nürnberg GmbH Ostendstraße 80-90 90482 Nürnberg T: +49(0)911 54 32-0 F: +49(0)911 54 32-130 [www.baumueller.com](http://www.baumueller.com)  
Baumüller Anlagen-Systemtechnik GmbH & Co. KG Ostendstraße 84 90482 Nürnberg T: +49(0)911 544 08-0 F: +49(0)911 544 08-719  
Baumüller Reparaturwerk GmbH & Co. KG Andernacher Str. 19 90411 Nürnberg T: +49(0)911 95 52-0 F: +49(0)911 95 52-999

All data/information and particulars given in this brochure is non-binding customer information, subject to constant further development and continuously updated by our permanent alteration service. Please note that all particulars/figures/information is current data at the date of printing. These particulars are not legally binding for the purpose of measurement, calculation or cost accounting. Prior to using any of the information contained in this brochure as a basis for your own calculations and/or applications, please inform yourself about whether the information you have at your disposal is up to date. Therefore, no liability is assumed for the correctness of the information.

2.179.e.02/05.05B  
02/05