

# ACCU ELECTRIC MOTORS INC

USA: (888) 932-9183

CANADA: (905) 829-2505

- ✓ Over 100 years cumulative experience
- ✓ 24 hour rush turnaround / technical support service
- ✓ Established in 1993



The leading independent repairer of servo motors and drives in North America.

Visit us on the web:

[www.servo-repair.com](http://www.servo-repair.com)

[www.servorepair.ca](http://www.servorepair.ca)

[www.ferrocontrol.com](http://www.ferrocontrol.com)

[www.sandvikrepair.com](http://www.sandvikrepair.com)

[www.accuelectric.com](http://www.accuelectric.com)

**Scroll down to view your document!**

For 24/7 repair services :

USA: 1 (888) 932 - 9183

Canada: 1 (905) 829 -2505

Emergency After hours: 1 (416) 624 0386

Servicing USA and Canada



## 1391B-ES AC Servo Controller User Manual

### Introduction

This publication provides updated information for the 1391B-ES Instruction Manual (1391ES-5.0, dated October, 1992). Please place this publication with your manual for future reference.

### Page 1-3

The following material is new and should be added at the end of “Controller Description.”

The 1391-EST45 combines all of the features of the 1391B-ESAA45 with the addition of 300% peak current capability. The controller can be ordered with A Quad B encoder feedback and is available in the 45A size only.

### Page 1-4

The following is updated Option/Modification information.

- Anti-Backlash  
Provisions to use the 1388 Anti-Backlash module (1388-XA) are available.
- Linear Accel/Decel  
Linear accel/decel can be set using the CR-APG-001 Control Module. This module provides a manually generated trapezoidal velocity profile for up to four preset speeds. A single acceleration/deceleration rate can be set for all speeds.

### Page 2-1

The Controller Specifications shown on the following page have been updated to include the 1391-EST45.

| <u>Specific Ratings – 1391B- . . .</u>                    | <u>ESAA15</u> | <u>ESAA22</u> | <u>ESAA45</u> | <u>EST45</u> |
|---|---------------|---------------|---------------|--------------|
| Nominal Bus Output Voltage                                | 300V DC       | 300V DC       | 300V DC       | 300V DC      |
| Continuous Current (RMS)                                  | 15A           | 22.5A         | 45A           | 45A          |
| Peak Current (RMS)  | 30A           | 45A           | 90A           | 135A         |
| Continuous Power Output                                   | 5.0 kW        | 7.5 kW        | 15.0 kW       | 15.0 kW      |
| Peak Power Output   | 10.0 kW       | 15.0 kW       | 30.0 kW       | 45.0 kW      |
| Input Circuit Breaker Rating                              | 17A RMS       | 26A RMS       | 38A RMS       | 38A RMS      |
| Circuit Breaker Interrupt Rating<br>(Symmetrical Amperes) | 1300A         | 1300A         | 1300A         | 1300A        |
| Unit Weight in lbs. (kg)                                  | 22 (9.97)     | 28 (12.69)    | 34 (15.40)    | 37 (16.78)   |

**All Controller Ratings**

|   |  |
|---|--|
| Static Gain (A/RMS)                                       | 1.5 x Rated Motor Current / rpm  |
| Form Factor   | 1.03 or less   |
| Speed Regulation<br>change                                | 0.05% (max.) of maximum motor speed with 95% load  |
| Peak Current Limit Adjust<br>1391B-ES<br>continuous drive | 20 to 300% of Rated Motor Current (to 2 times<br>rating, maximum)  |
| 1391-EST45<br>continuous drive                            | 20 to 300% of Rated Motor Current (to 3 times<br>rating maximum or 135A.<br>Note: Peak current time varies with RMS current history.                       |
| IT<br>current.<br>for 130 ms                              | (current-time) history is used to determine available peak<br>current.<br>For example: With 30A “soak,” 300% peak is available<br>or more with lower soak. |
| Controller Efficiency<br>(Minimum at Rated Load)          | 85%  |
| Modulation Frequency                                      | 2500 Hz ±10%   |
| Drift (Referred to Tach)                                  | 0.07 rpm /Degrees C. Maximum   |
| Ambient Temperature                                       | 0 to 60° C (32 to 140° F)  |
| Storage Temperature                                       | 0 to 65° C (32 to 149° F)  |
| Input Voltage (from Transformer)                          | Power: 230V AC, Three-Phase, 50/60 Hz ±3 Hz<br>Control: 36V AC CT, Single-Phase  |
| Relative Humidity   | 5 to 95% Non-Condensing  |
| Deadband  | Zero   |
| Altitude  | 1000 meters (3300 feet)  |
| Integral Fan Output                                       | 50 CFM (Unloaded)  |
| Max. RMS Short Circuit Current<br>(Symmetrical Amperes)   | 1300A  |
| Transformer Input Tolerance                               | +10%, -15%   |

*Specifications are for reference only and are subject to change without notice.*

Page 3-3 through 3-7

Several catalog number descriptions have been clarified. Descriptions for the 1391-EST controller and Planetary Gearbox have been added.





Power and Feedback Cables

1326 – C P A T 15  
B

| First Position  |                | Second Position |                            | Third Position |                                      | Fourth Position    |                                 | Fifth Position    |   | Sixth Position |                          |
|-----------------|----------------|-----------------|----------------------------|----------------|--------------------------------------|--------------------|---------------------------------|-------------------|---|----------------|--------------------------|
| Bulletin Number |                | Type            |                            | Function       |                                      | Motor Size Used On |                                 | Power Track Cable |   | Cable Length   |                          |
| Letter          | Description    | Letter          | Description                | Letter         | Description                          | Code               | Type                            | Letter            | Description                                 | Code           | Description              |
| Blank           | Standard Cable | C               | Connector & Cable Assembly | P              | Power Connection                     | AB                 | Series A & B (except 1326AB-B4) | T                 | All Series, used for high flex applications | K              | Connector Kit (No Cable) |
|                 |                |                 |                            | F              | Commutation & Feedback Connection    | U                  | Series C & 1326AB-B4            | Blank             | Standard Cable                              | 15             | 15' (4.6m)               |
|                 |                |                 |                            | E              | 845H/T Encoder                       |                    |                                 |                   |   | 30             | 30' (9.1m)               |
|                 |                |                 |                            | V              | All 4.25" (108 mm) Resolver Packages |                    |                                 |                   |   | 50             | 50' (15.2m)              |
|                 |                |                 |                            |                |                                      |                    |                                 |                   |   | 100            | 100'                     |
|                 |                |                 |                            |                |                                      |                    |                                 |                   |   | 150            | 150'                     |
|                 |                |                 |                            |                |                                      |                    |                                 |                   |   | 200            | 200' (61m)               |
|                 |                |                 |                            |                |                                      |                    |                                 |                   |   | 250            | 250' (76.2m)             |
|                 |                |                 |                            |                |                                      |                    |                                 |                   |   | 300            | 300' (91.4m)             |

Page 5-3

In Figure 5.1, a cable specification has been added to Note 1. Note 2 has been clarified.

- Recommended Wire – Belden #9728 or equivalent. Maximum distance between the A Quad B Board and the position controller is 40 feet (12.2 meters) using a 5 volt signal. For distances up to 300 feet (91 meters), 18 AWG (0.8 mm<sup>2</sup>) wire (Belden 9388 or equivalent) and an 8 to 15V DC power supply must be used.
- For proper operation when interconnecting to IMC Classic products (i.e. IMC 110, 12x), the B and B (NOT) signals must be reversed.

Page 5-4

**External Shunt Regulator Resistor** (TB5, Terminals 8, 9, 10)

The following sentence supplements the current material.

Bus voltage can be monitored on terminals 9 (+) and 7 (-) of TB5.

Page 5-8

Scaling information for the 1326AB-A1G motor has been added.

Table 5.C  
Typical Scaling for 1326 AC Servomotors

| Motor Catalog Number <sup>2</sup> | I <sub>C</sub> (A) | S1 Switch Setting <sup>1</sup> |             |             |
|-----------------------------------|--------------------|--------------------------------|-------------|-------------|
|                                   |                    | 1391B-ESAA1                    | 1391B-ESAA2 | 1391B-ESAA4 |
| 1326AB-A1G                        | 4.5                | 5                              | 2           | 5           |
|                                   |                    | 4                              | 3           |             |

Page 5-10

The S2 switch setting for the 1326AB-A1G motor has been added.

Table 5.E  
S2-2 Switch Positions

| Motor Catalog Number <sup>1</sup> | S2-2 Switch Setting |
|-----------------------------------|---------------------|
| 1326AB-A1G                        | ON                  |

Page 5-12

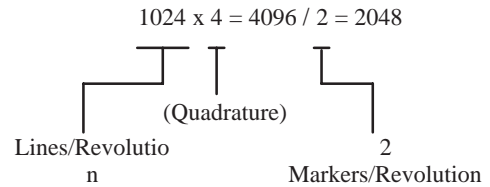
The following information has been clarified for use with IMC Classic products.

When using the A Quad B option with Allen-Bradley IMC motion controllers, the AMP parameters will be set according to the line count selected. In general, one parameter must be justified when using this device.

**Important:** For all IMC Classic products (IMC 110, 12x) the normal line counts per cycle of the encoder must be divided by two since the controller will see two markers per cycle.

**Example** (using an IMC 12x Controller)

With switch S3 set to 1024 lines per revolution (S3-2 OFF, S3-1 ON), the lines per cycle of the position feedback device (located in the Feedback Parameters File) must be 2048.



Page 6-5

### Encoder (A Quad B Board) Wiring

The following information supplements the current material.

For proper operation when interconnecting to IMC products, the B and B (NOT) signals must be reversed.

Applications that interface the 1391B-ES with an IMC Classic Controller (IMC 110, 120, 121, 123) require a relay to sequence the encoder power supply during a controller shutdown.

Without this power supply relay, erroneous counts could be received by the IMC Classic Controller when AC power is cycled to the 1391B-ES, but not the IMC controller. When power is removed to the 1391B-ES, the AQB Board will not have control voltage. However, the board will still receive the encoder voltage (+5V DC or +8-15V DC) from the IMC Classic Controller. As the 1391B-ES power is cycled, it will briefly output a stream of encoder pulses which will be interpreted as movement of the servomotor by the IMC Classic Controller.

It is recommended that a normally open (N.O.) contact from an external relay be wired in series with the encoder voltage going to the 1391B-ES from the IMC Classic Controller. The relay coil must be wired into the control circuit. When power is not applied to the 1391B-ES, a Quadrature Fault will occur in the controller, forcing a re-homing and calibration of the controller.

Page 7-4

The following error example should be added to step 15.

$$\text{Following Error} = \frac{\text{Velocity}}{\text{Gain}} = \frac{100 \text{ ipm}}{1 \text{ ipm/ml}} = 100 \text{ ml}$$

Page 7-6

### Linear Accel/Decel Control Module

The following information is new and explains manual controller operation with the Linear Accel/Decel Control Module (CR-APG-001). This module provides adjustable acceleration/deceleration control for the 1391B-ES. Up to four remote or local preset speeds are available.

The 1391B-ES can be manually operated with controlled trapezoidal motion profiles when the module is installed and the following steps are performed.

- o 1. Perform the Start-Up Procedure presented earlier in this chapter.
- o 2. Remove all system power.
- o 3. Install and interconnect the Linear Accel/Decel Control Module as shown in Figure 7.3. Refer to Figure 7.4 for dimension information.

- o 4. Set all of the Speed pots (SPD 1-SPD 4 or remote pots) to the maximum clockwise position (speed minimum). Set the front panel Accel and Decel pots to the maximum counterclockwise position (minimum accel/decel time).

**Important:** All potentiometers on the module are 15 turn, bi-directional. The Local Speed pots are setup such that counterclockwise rotation will increase output and clockwise rotation will decrease output. Counterclockwise rotation of the Accel/Decel pots will decrease time, while clockwise rotation will increase time.

- o 5. Apply 115V AC to terminals 1 & 2 of J3. Using a voltmeter, verify that this voltage is present. Also verify that +10V DC is present between terminals 9 (+) and 2 (-) of J1. The “ON/OFF” LED located on the front of the module will be illuminated.
- o 6. Select Remote or Local speed control.

#### To select Remote Speed

- a) Connect an external, 1k ohm, 1/2 watt speed potentiometer as shown in Figure 7.3.
- b) Energize the R/L 1 input (terminals 3 & 4 of J2) with either 24V DC or 115V AC.
- c) Energize the speed select input, SEL 1 (terminals 1 & 2 of J2) with the same voltage used in the previous step. The front panel “R/L 1” LED will illuminate.
- d) Repeat steps *a* through *c* for any of the other three preset speeds.

**Important:** If more than one speed is selected at the same time, the resulting speed for the velocity profile will not be predictable.

#### To select Local Speed

- e) Energize the speed select input, SEL 1 (terminals 1 & 2 of J2) with either 24V DC or 115V AC. The front panel “SEL 1” LED will illuminate.
- f) Repeat the above step for any of the other three preset speeds.

**Important:** If more than one speed is selected at the same time, the resulting speed for the velocity profile will not be predictable.

**Important:** In the following steps, the local speed control (SPD 1) will be used. If your application utilizes remote speed pots, the remote pot should be substituted for SPD 1.

- o 7. Connect a voltmeter between terminals 11 (+) and 10 (–) of J1. While monitoring the meter, turn the speed pot (SPD 1 or remote) counterclockwise until the output voltage is approximately +10V DC. Toggle the FWD/REV switch. The voltage measured should change in polarity.  
  
If the polarity does not change, recheck the wiring and connections of the FWD/REV relay and switch.  
  
**Important:** Changing direction with the speed input follows the accel/decel times set on the module.
- o 8. Move the meter leads to controller terminals 1 (–) & 2 (+) of TB2. The meter should indicate a voltage of approximately +10V DC.
- o 9. Rotate the Accel and Decel pots (located on the module front panel) approximately 7 turns.
- o 10. De-energize the SEL 1 input (terminals 1 & 2 of J2) and note the time needed for the meter voltage to reach zero (minimum) volts. Energize the SEL 1 input and note the time needed for the voltage to reach +10V DC (maximum).
- o 11. Adjust the Accel/Decel pots for desired ramp times (approximate range is 0.25 to 6.5 seconds) by repeating step 10. The final ramp time will be set during final system calibration. Rotate the speed pot fully clockwise for minimum speed. Remove the SEL1 input.



**ATTENTION:** To protect against rapid accel/decel commands from the module and possible machine damage or personal injury, the “Bypass” input (terminals 19 & 20 of J2) must not be energized. Applying 24V DC or 115V AC to this input will remove the Accel/Decel pot settings from the circuit, causing the output to immediately ramp to +10V DC or zero volts.

---

- o 12. The output of the module is controlled by the “Deadman” input at terminals 10 & 11 of J1. Applying 24V DC or 115V AC to this input will cause the module to operate. The front panel “Dedman” LED will be off. When this input is de-energized, the module output will be connected to logic ground, thus disabling output. At this point the “Dedman” LED will illuminate.  
  
Energize the “Deadman” input with 24V DC or 115V AC.



**ATTENTION:** During subsequent steps, the servomotor may begin to rotate and cause incorrect machine movement when the controller is enabled. Be prepared to remove power by opening (MCB) or the branch circuit disconnect device if this occurs. This movement may be due to a wiring error or system component malfunction and must be corrected before proceeding with this procedure. Damage to machine system components can occur due to uncontrolled machine movements.

- o 13. Apply power to the controller and module. Initiate a Start command by selecting speed input, SEL1. Command a speed through the speed pot, SPD 1 that represents approximately 10% of maximum speed (i.e. 1V DC).

The motor should rotate slowly under control (following the speed pot). If the motor is uncontrollable or rotates incorrectly, de-energize SEL 1. Remove all power and check wiring.

If the controller current limit function is used – slowly adjust the Current Limit potentiometer (R148) to the desired setting after the motor is stable. Refer to Chapter 5 for more information on the this potentiometer.

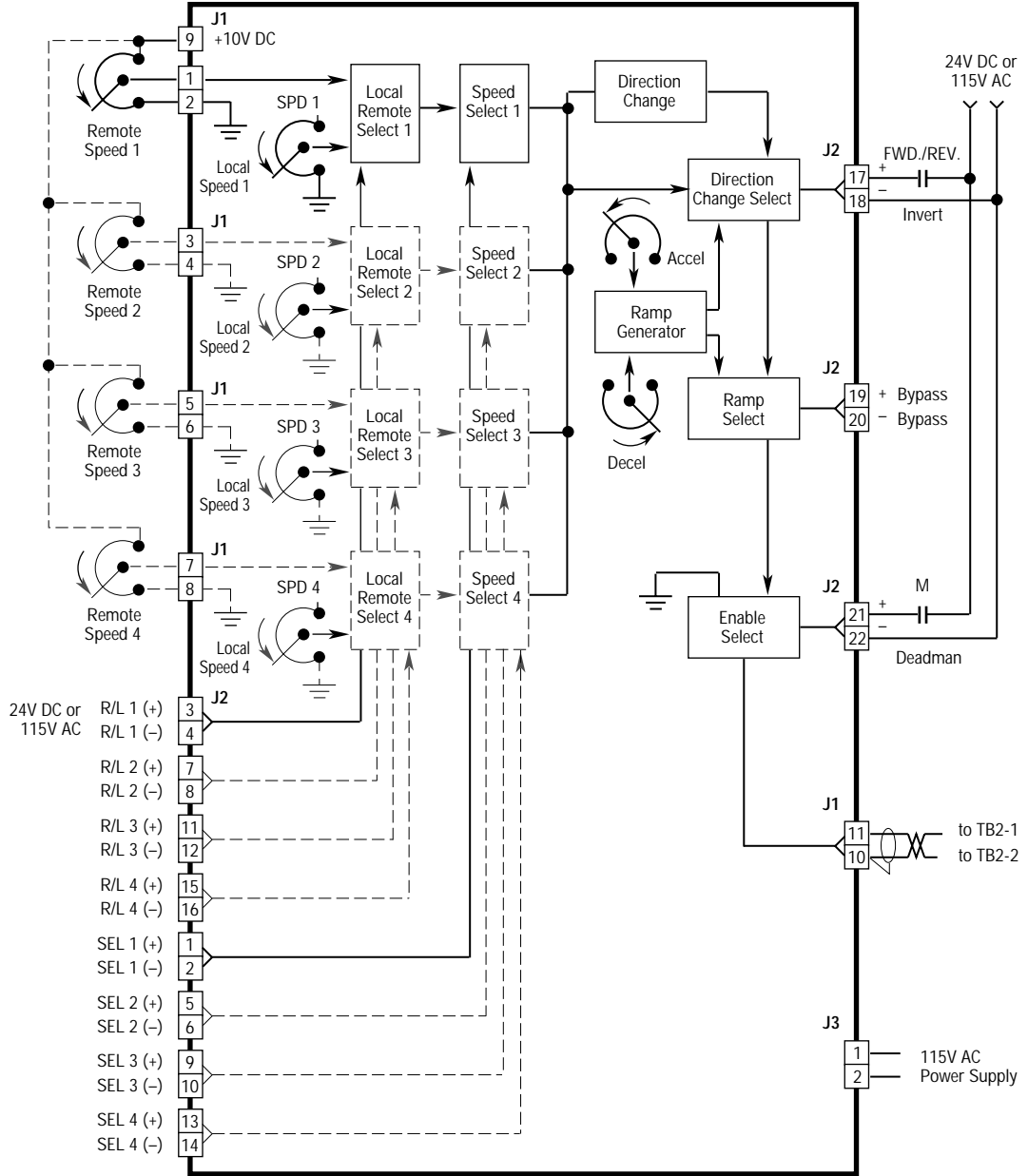
If the application requires reverse direction, use the FWD/REV toggle switch to check operation in the reverse direction.

- o 14. With a zero velocity command from the module, use the controller Offset pot (R1) to set zero motor speed. Refer to Chapter 5 for more information on this adjustment.

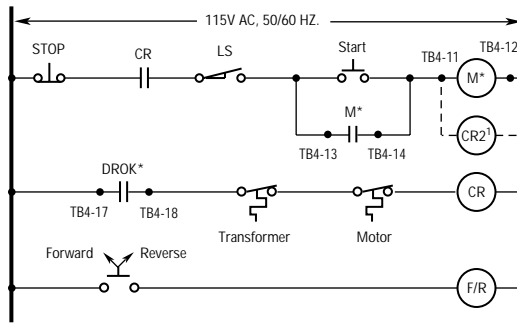
**Important:** The motor may begin to move slowly after a period of time (several minutes) even though the Offset pot is set to zero.

- o 15. Rotate the speed pot (SPD 1) fully counterclockwise. Adjust the Velocity Command Scale pot (R132) to give the desired motor speed.
- o 16. Check the accel/decel rate settings at speeds selected for the application. Refer to steps 10 & 11.
- o 17. If applicable, repeat steps 6-16 for any of the other three preset speeds

Figure 7.3  
Linear Accel/Decel Control Module Wiring

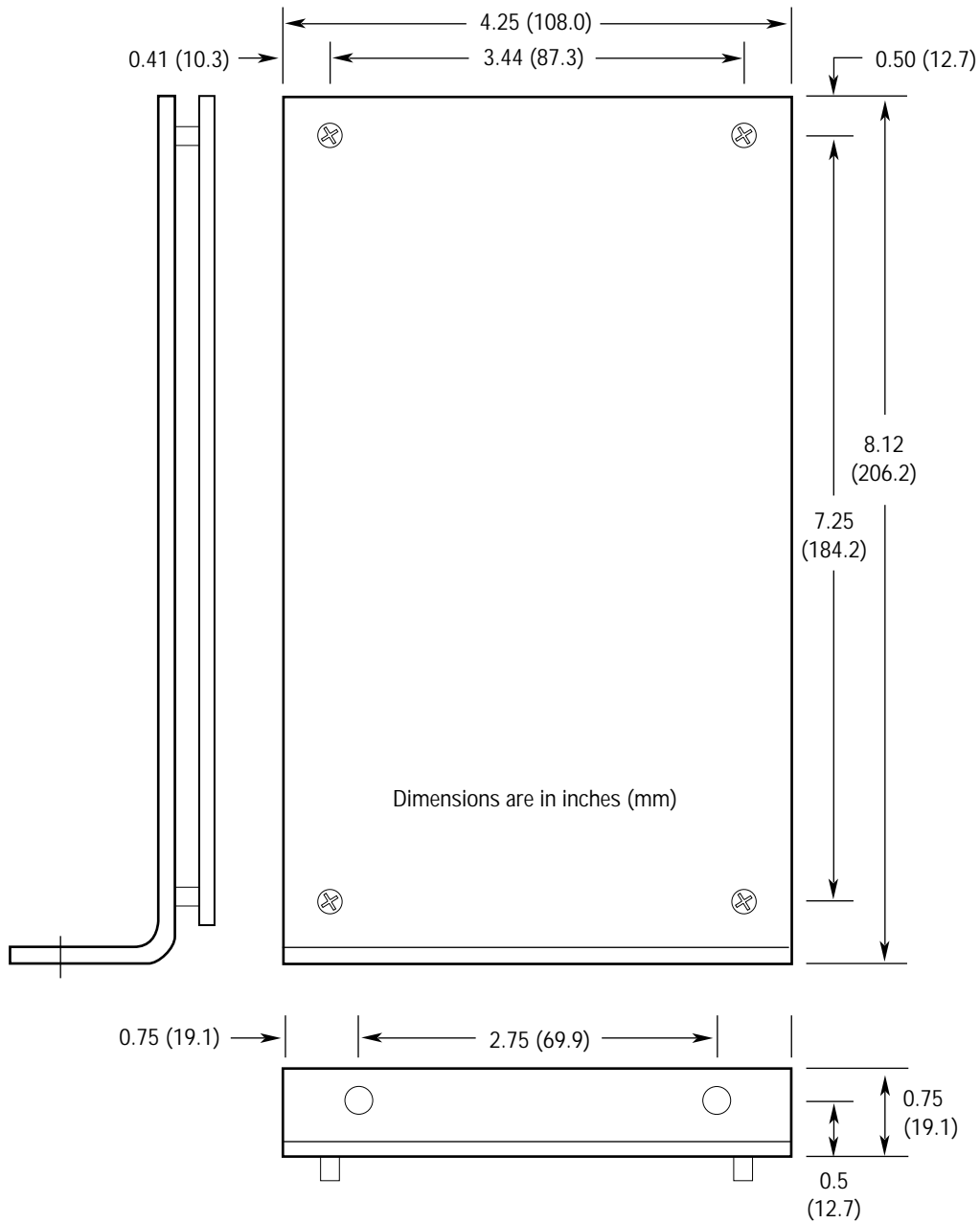


TYPICAL CONTROL CIRCUIT



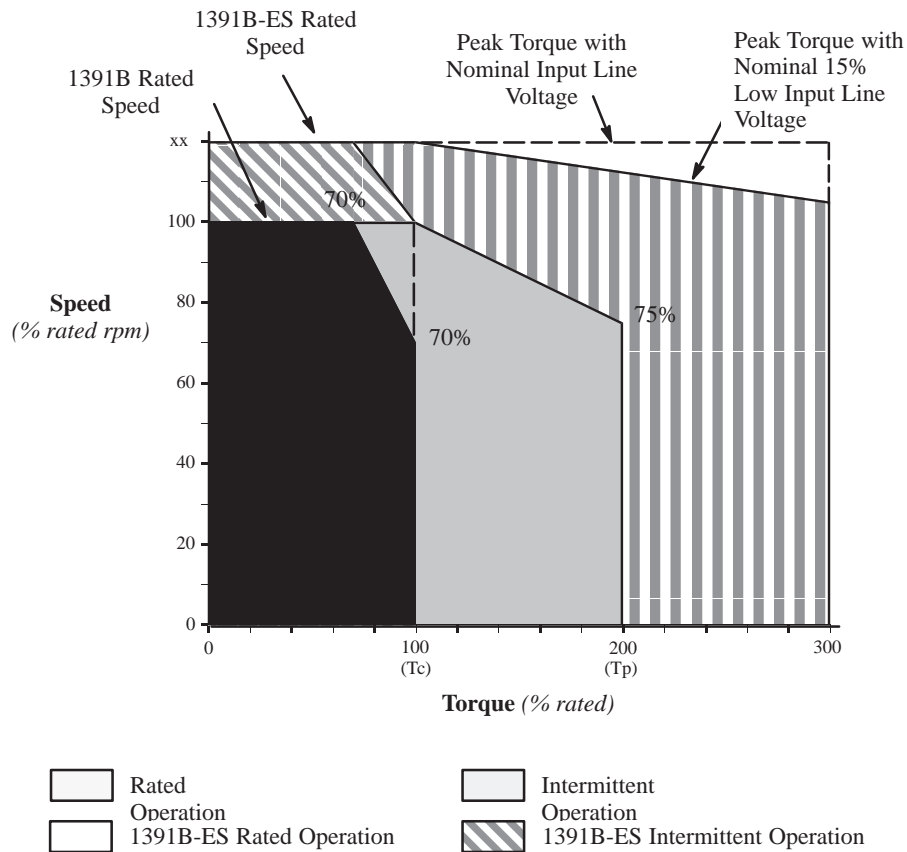
\* Indicates component located in controller  
<sup>1</sup> Required only with IMC 110, 120, 121 AND 123 controllers

Figure 7.4  
Linear Accel/Decel Control Module Dimensions



The Speed-Torque Curve shown in Figure 8.1 has been updated to 300% rated torque.

Figure 8.1  
Typical Bulletin 1326 Speed-Torque Curve



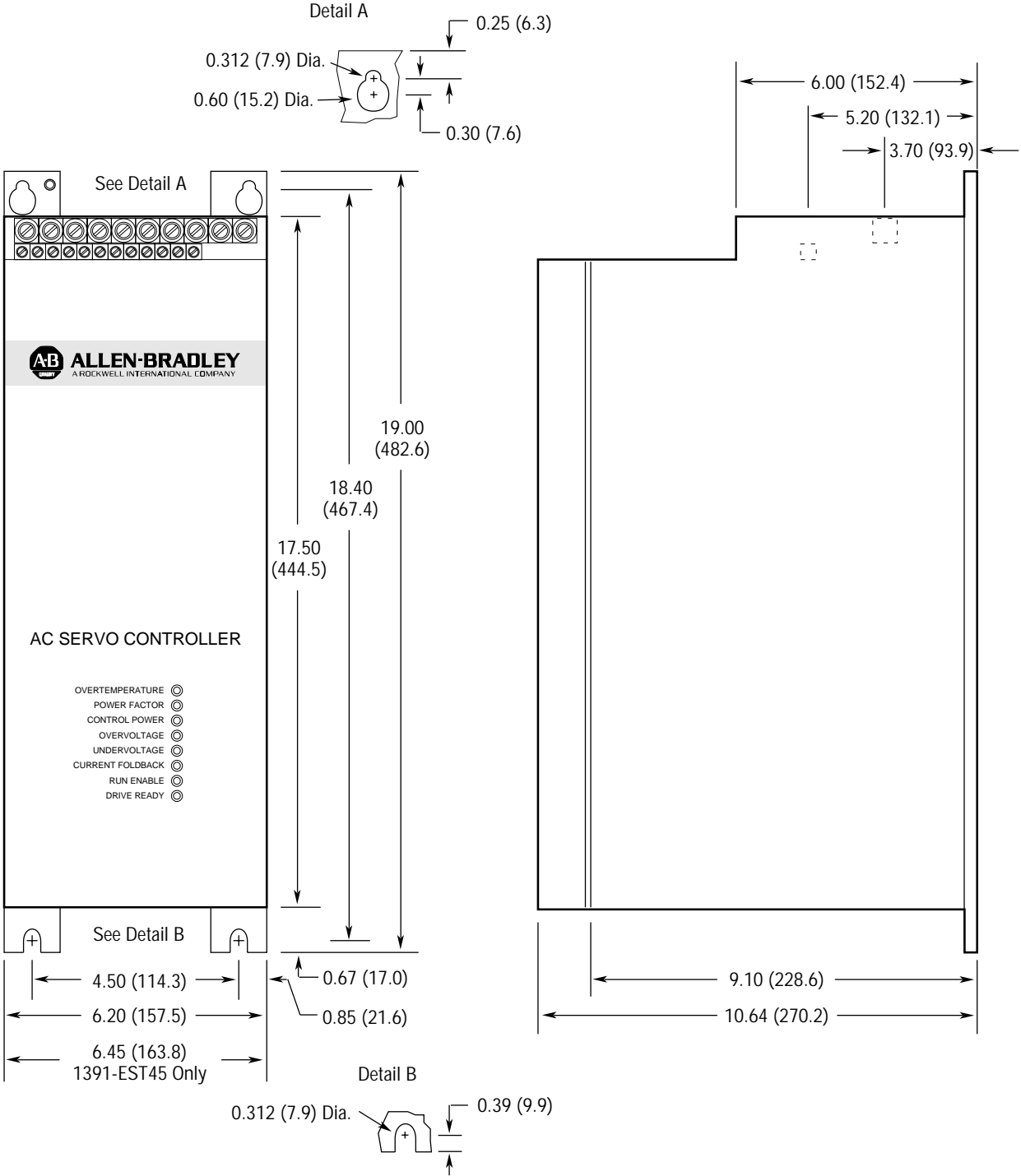
Speed comparisons with the 1391-EST drive have been added to Table 8.A.

Table 8.A  
1391/1391B-ES /1391-EST Speed Comparison

| Continuous Stall Torque<br>(lb.-in./<br>N-m) | Peak Stall Torque<br>(lb.-in./<br>N-m) | Rated Speed<br>(rpm) | Motor Catalog Number | Servo Amplifier Catalog Number | Amperes at Continuous Torque | Rotor Inertia<br>(lb.-in.-s <sup>2</sup> /kg-m <sup>2</sup> ) | Rated Output<br>(kW) |
|--|--|----------------------|----------------------|--------------------------------|------------------------------|---|----------------------|
| 210/23.7                                     | 630/71.2                               | 4000                 | 1326AB-C2E           | 1391-EST45                     | 33.2                         | 0.14/0.015  | 6.9                  |
| 310/35.0                                     | 852/96.3                               | 3000                 | 1326AB-C3E           | 1391-EST45                     | 49.1                         | 0.22/0.024  | 10.0                 |
| 420/47.4                                     | 1217/137.5                             | 2000                 | 1326AB-C4C           | 1391-EST45                     | 46.6                         | 0.29/0.032  | 9.3                  |
| 420/47.4                                     | 1260/142.4                             |                      | 1326AB-C4B           | 1391-EST45                     | 38.2                         | 0.29/0.032  | 7.5                  |

A dimension has been added to cover the 1391-EST45 controller.

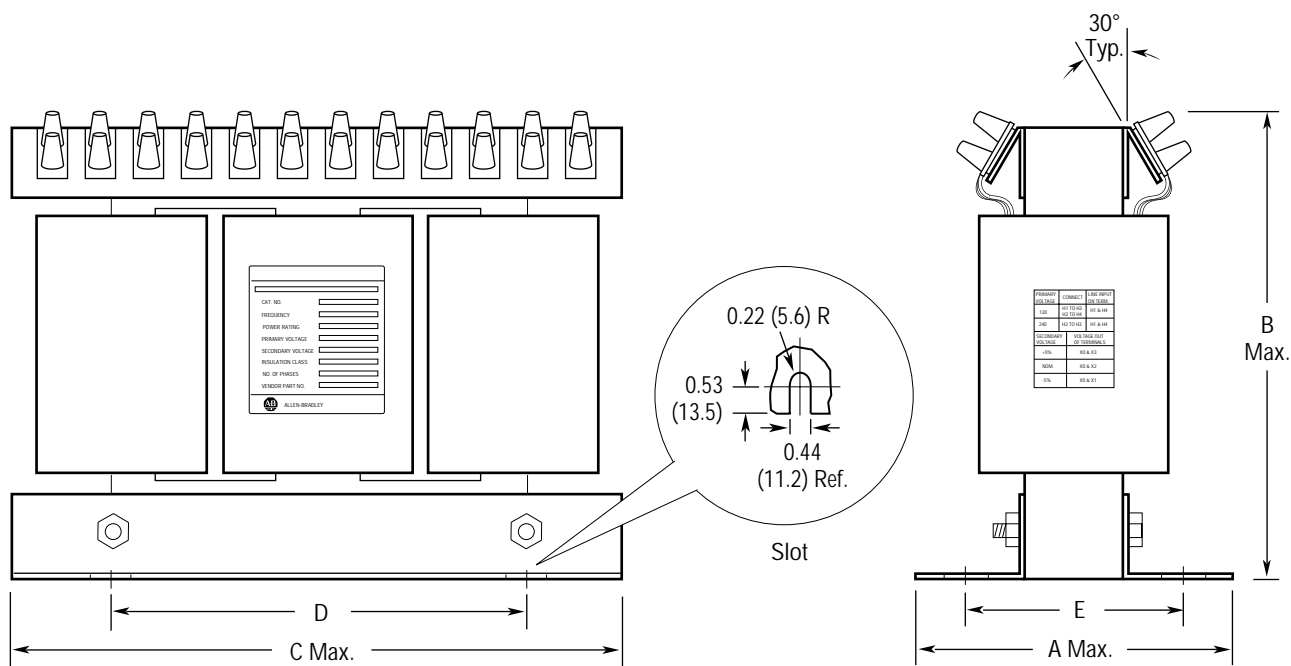
**Figure A.1**  
**1391B-ES/1391-EST Dimensions**  
 Dimensions are in inches and millimeters



- Notes:
1. Dimensions are in inches (millimeters)
  1. Mounting slots and keyholes will accept 1/4-20 (7 mm) hardware.
  2. A minimum spacing of 0.312" (7.9 mm) is required between adjacent controllers – 1" (25.4 mm) is recommended.

“NT” has been added to the catalog numbers shown and “Europa” style terminal blocks have been incorporated into the transformer design.

Figure A.2  
1391 Isolation Transformer Dimensions  
Dimensions are in inches and (millimeters)



| Catalog Number     | kVA  | A           | B           | C           | D          | E          | Weight     |
|--------------------|------|-------------|-------------|-------------|------------|------------|------------|
| 1391-T015DT        | 1.5  | 9.00 (228)  | 10.00 (254) | 13.00 (330) | 5.00 (127) | 3.10 (79)  | 27 (12.2)  |
| 1391-T015ET/<br>NT |      | 9.00 (228)  | 10.00 (254) | 13.00 (330) | 5.00 (127) | 3.50 (89)  | 40 (18.2)  |
| 1391-T025DT        | 2.5  | 11.00 (279) | 11.00 (279) | 14.00 (356) | 6.00 (152) | 3.30 (84)  | 42 (19.0)  |
| 1391-T025ET/<br>NT |      | 11.00 (279) | 11.00 (279) | 14.00 (356) | 6.00 (152) | 4.00 (102) | 60 (27.2)  |
| 1391-T035DT        | 3.5  | 11.00 (279) | 11.00 (279) | 14.00 (356) | 6.00 (152) | 4.50 (114) | 60 (27.2)  |
| 1391-T035ET/<br>NT |      | 11.00 (279) | 11.00 (279) | 14.00 (356) | 6.00 (152) | 4.50 (114) | 85 (38.6)  |
| 1391-T050DT        | 5.0  | 11.00 (279) | 11.00 (279) | 14.00 (356) | 6.00 (152) | 5.25 (133) | 75 (34.0)  |
| 1391-T050ET/<br>NT |      | 11.00 (279) | 11.00 (279) | 14.00 (356) | 6.00 (152) | 6.00 (152) | 100 (45.4) |
| 1391-T100DT        | 10.0 | 12.00 (305) | 12.50 (317) | 16.00 (406) | 8.00 (203) | 5.85 (149) | 112 (50.8) |
| 1391-T100ET/<br>NT |      | 12.00 (305) | 12.50 (317) | 16.00 (406) | 8.00 (203) | 5.85 (149) | 140 (63.6) |
| 1391-T150DT        | 15.0 | 13.00 (330) | 14.00 (356) | 17.50 (444) | 9.50 (241) | 6.00 (152) | 150 (68.0) |
| 1391-T150ET/<br>NT |      | 13.00 (330) | 14.00 (356) | 17.50 (444) | 9.50 (241) | 6.00 (152) | 200 (90.9) |

Page A-3

The following items are included with the NEMA Type 1 Enclosure.

| <u>Qty.</u> | <u>Description</u>      |
|-------------|-------------------------|
| 2           | Steel Mounting Channels |
| 4           | 3/8-16 x 1.0 HHCS Screw |
| 4           | 3/8-16 x 1.5 HHCS Screw |
| 8           | 3/8 Flat Washer         |
| 8           | 3/8 Split Lock Washer   |
| 8           | 3/8-16 Hex Nuts         |

Appendix B

The following changes have been made to the interconnect diagrams in Appendix B. The diagrams on the following pages have been renumbered.

| <u>Figure</u> | <u>Diagram</u> | <u>Description of Change</u>   |
|---------------|----------------|--|
| B.1           | Interconnect   | Note added to C.T. of transformer. CR2 added to Control Circuit.                         |
|               |                | Note added to "M" Contact table. Capacitor added to resolver.                            |
| B.2, B.3      | IMC            | New diagrams. CR2 and M contact added.   |
| B.4           | 8400           | Removed.   |
| B.5           | 8600           | Removed.   |
| B.6           | MAX/CONTROL    | New diagram. Notes and terminal block designations have been clarified. M contact added. |
|               | IMC-S/20x      | New diagram.   |
|               | IMC-S/21x      | New diagram.   |
|               | IMC-S/23x      | New diagram.   |
|               | IMC-201        | New diagram.   |
|               | IMC 110        | New diagram.   |
|               | 9/Series       | New information.   |

Note 10 has been added.

Notes:

1) Power Wiring unless Noted:

|       |                                    |          |
|-------|------------------------------------|----------|
| 15A   | 12 AWG (3.3 mm <sup>2</sup> ) min. | 75C min. |
| 22.5A | 10 AWG (5.3 mm <sup>2</sup> ) min. | 75C min. |
| 45A   | 8 AWG (8.4 mm <sup>2</sup> ) min.  | 75C min. |

2) Signal Wiring: 18 AWG (0.8 mm<sup>2</sup>) min.

3) Allen-Bradley Supplied Cable:

|                                     |        |
|-------------------------------------|--------|
| 8 AWG (8.4 mm <sup>2</sup> ) Motor  | 126473 |
| 12 AWG (3.3 mm <sup>2</sup> ) Motor | 126474 |
| Resolver                            | 116190 |

4) Customer Supplied Resolver Cable:

Belden 9873 or equivalent, 20 AWG (0.5 mm<sup>2</sup>), 30 pf/ft (97.5 pf/m) max. capacitance between conductors.

5) Terminate shield on source end only.

6) Do not make connections to unused pins on the resolver connector.

7) F3 provided on 15 & 22.5a units only. 15A=KLM-10, 22.5A=FNQ 6 1/4 series B only.

8) S2-1 ON for 1.2V/krpm, S2-1 OFF for 2.0V/krpm

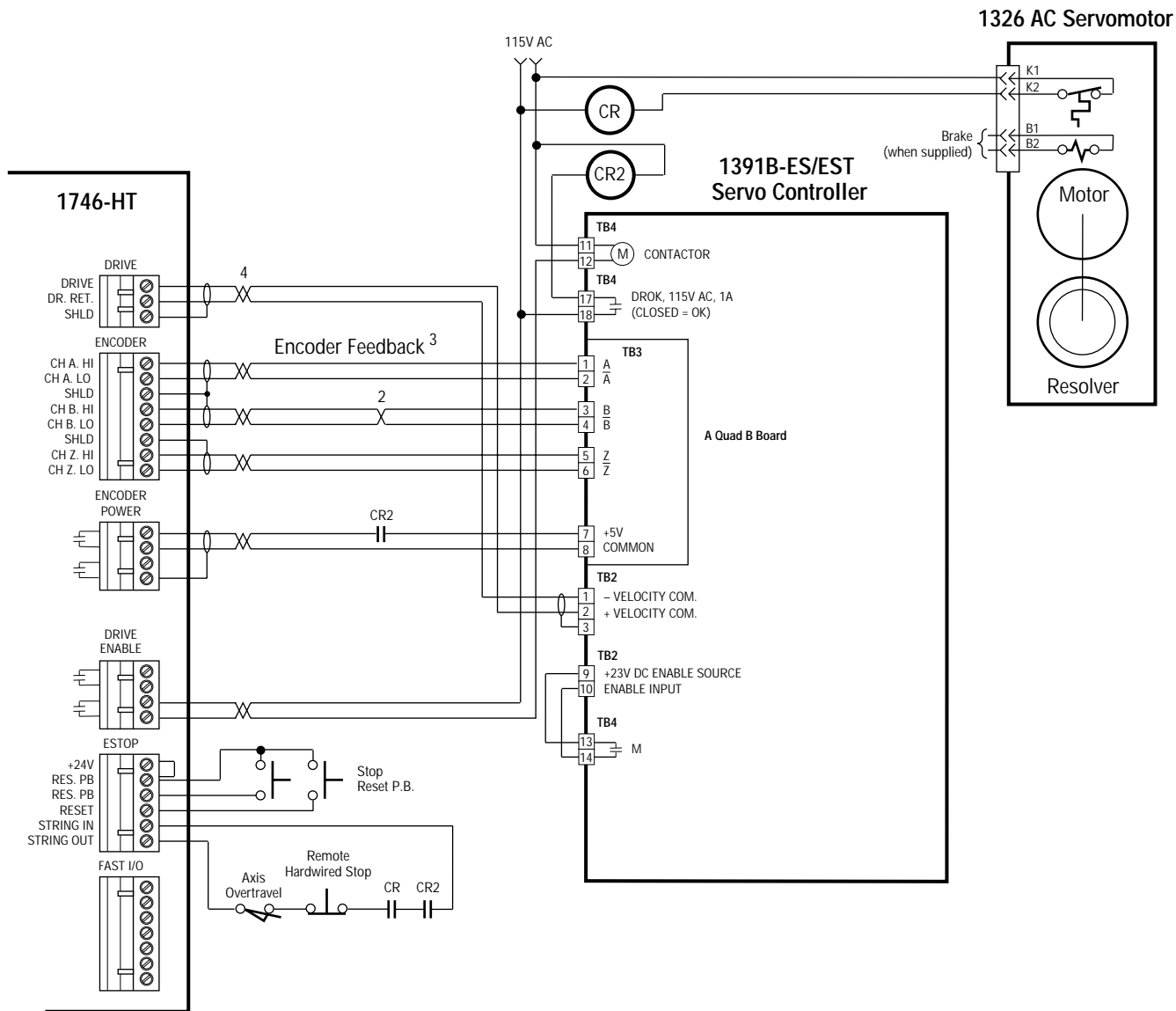
9) Current Feedback Scaling: See Chapter 5

10) On all Series D controllers (verify with controller nameplate) the secondary center tap must not be grounded. Grounding this will cause damage to the controller.

Figure B.1  
1391B-ES/1391-EST Interconnect Diagram

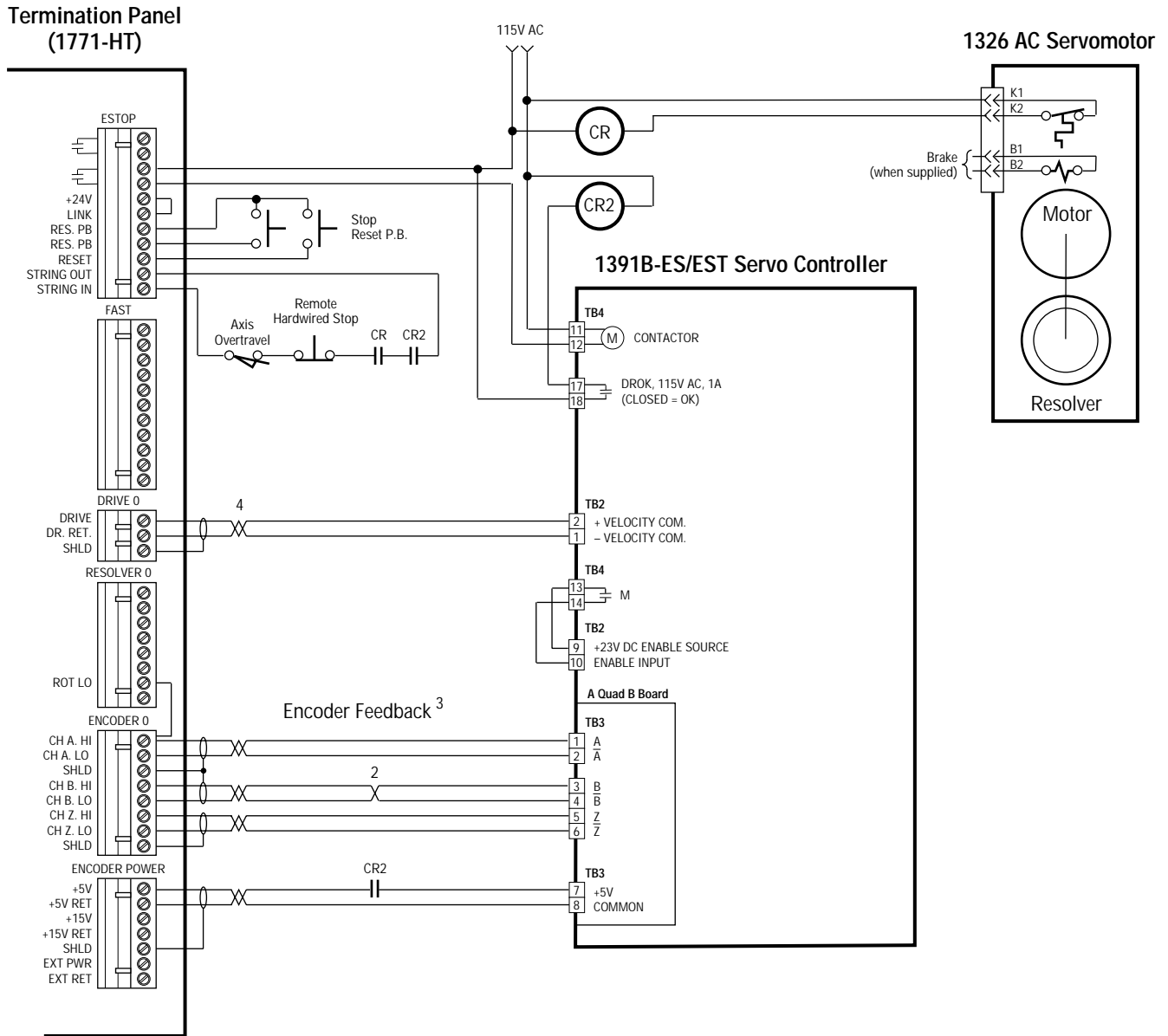


Figure B.2  
Typical IMC 110 Interconnect Diagram



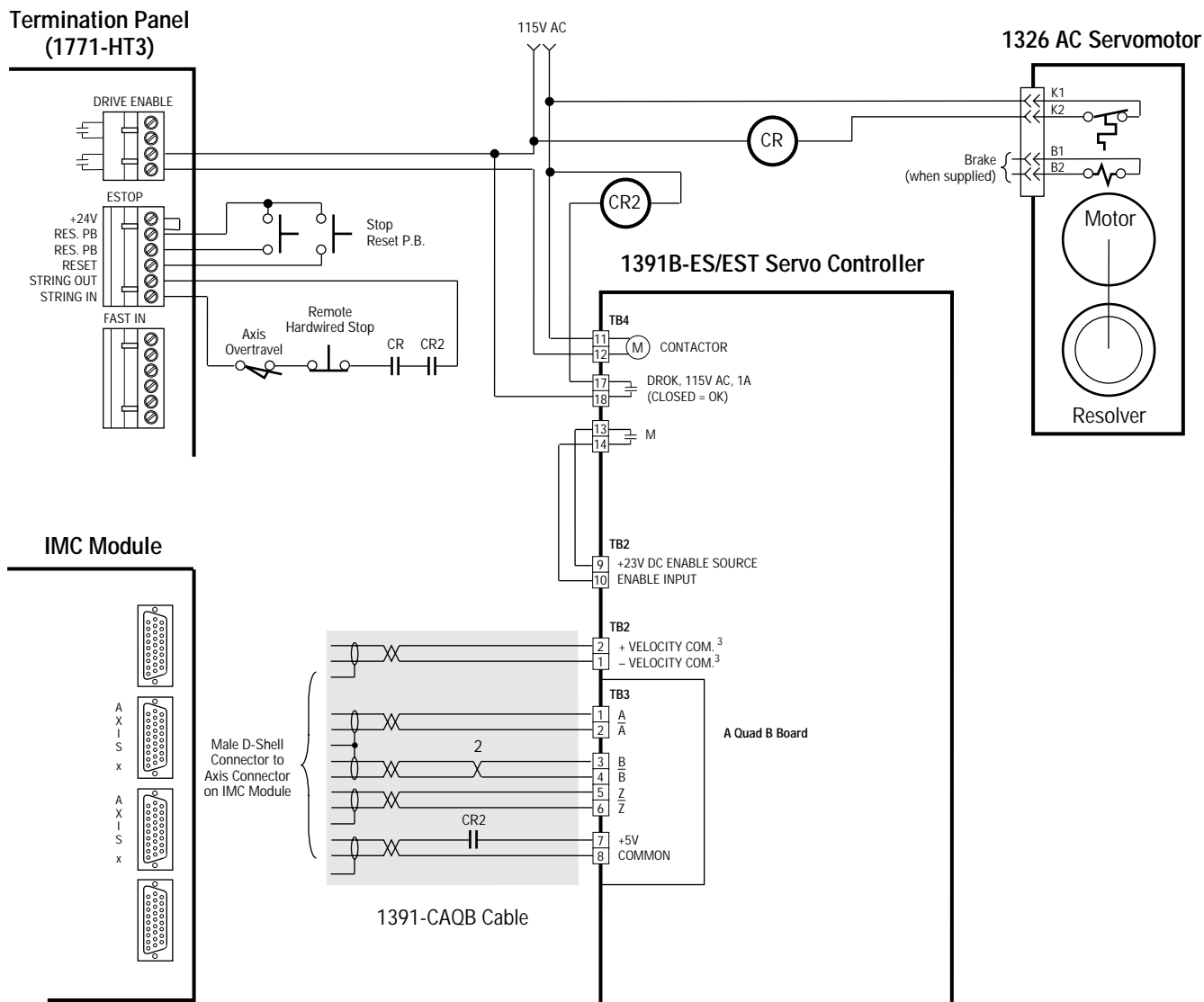
- <sup>1</sup> Refer to the 1391B-ES Interconnect Drawing for further details.
- <sup>2</sup> B and B (NOT) are interchanged.
- <sup>3</sup> Use Belden brand #9504 or equivalent twisted pair, shielded cable, 40 feet (12.2 meters) maximum. Shields grounded at controller only.
- <sup>4</sup> Use Belden brand #8760 or equivalent shielded cable.

Figure B.3  
Typical IMC 120 Interconnect Diagram <sup>1</sup>



- <sup>1</sup> Refer to the 1391B-ES Interconnect Drawing for further details.
- <sup>2</sup> B and B (NOT) are interchanged.
- <sup>3</sup> Use Belden brand #9504 or equivalent twisted pair, shielded cable, 40 feet (12.2 meters) maximum. Shields grounded at controller only.
- <sup>4</sup> Use Belden brand #8760 or equivalent shielded cable.

Figure B.4  
Typical IMC 121, 123 and 123CR Interconnect Diagram <sup>1</sup>

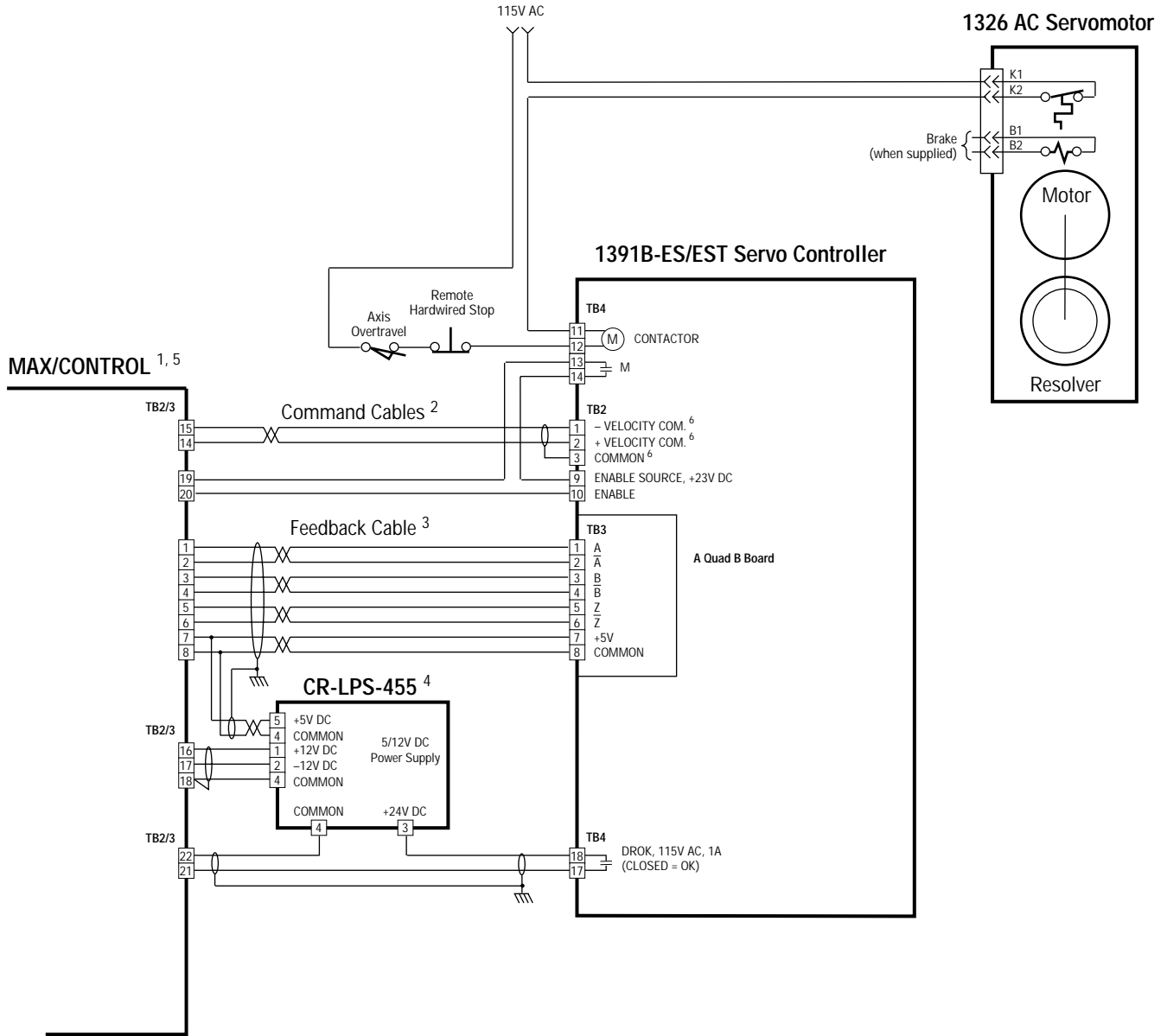


<sup>1</sup> Refer to the 1391B-ES Interconnect Drawing for further details.

<sup>2</sup> B and B (NOT) are interchanged.

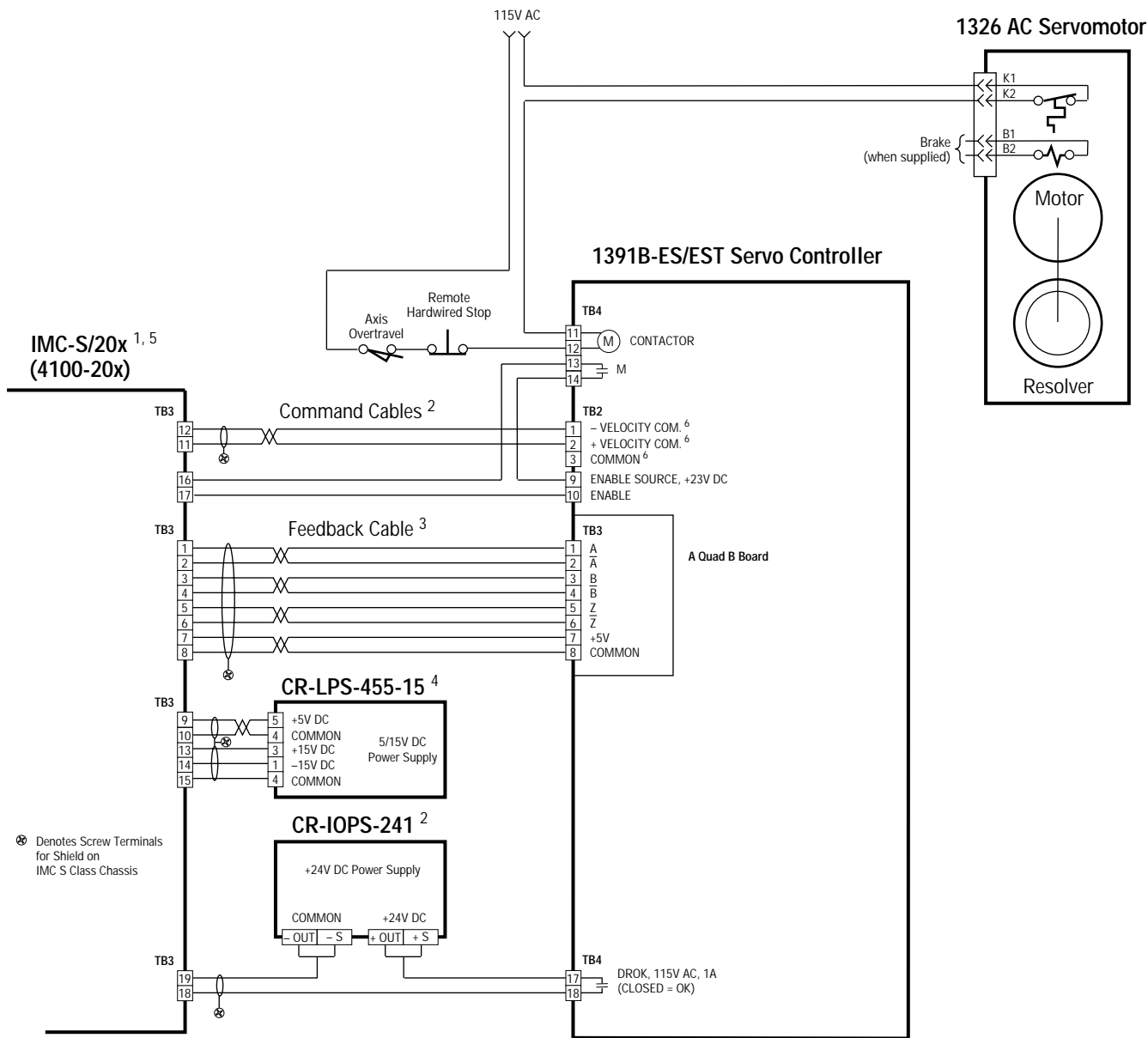
<sup>3</sup> If the drive is to be operated as a torque block from an IMC 121 or 123, command wires should be connected to TB2-15, 16 & 17.

Figure B.5  
Typical MAX/CONTROL Interconnect Diagram



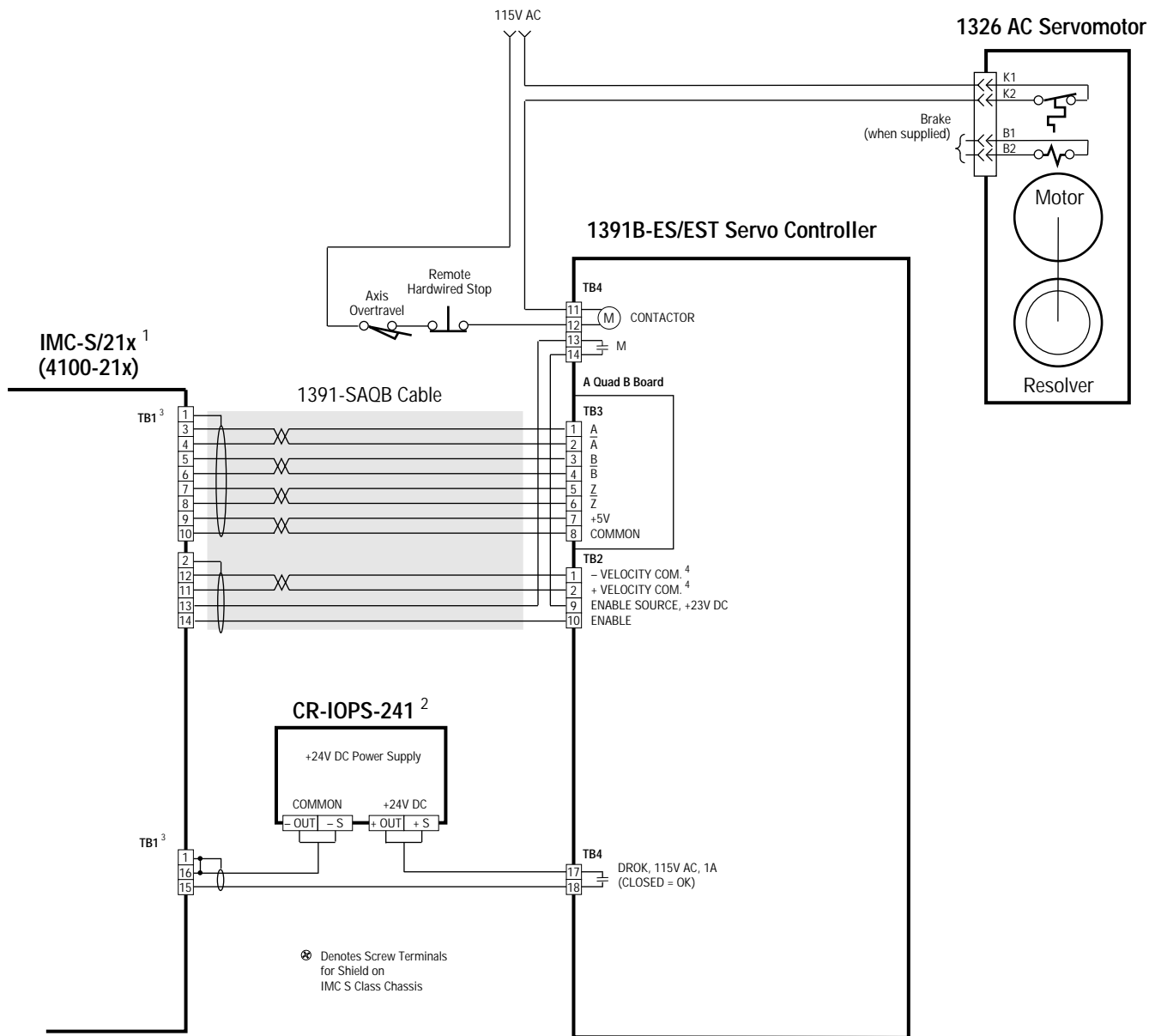
- 1 Refer to the MAX/CONTROL Installation and Setup Manual (999-051) and the 1391B-ES Interconnect Drawing for further details.
- 2 Use Belden brand #8760 or equivalent shielded cable.
- 3 Use Belden brand #9504 or equivalent twisted pair, shielded cable, 40 feet (12.2 meters) maximum. Shields grounded at controller only.
- 4 Use Belden brand #9533 or equivalent shielded cable.
- 5 X-axis connections are shown – Y-axis connections (TB3) are identical.
- 6 If the drive is to be operated as a torque block, command wires should be connected to 1391B-ES TB2-15, 16 & 17.

Figure B.6  
Typical IMC-S/20x Interconnect Diagram



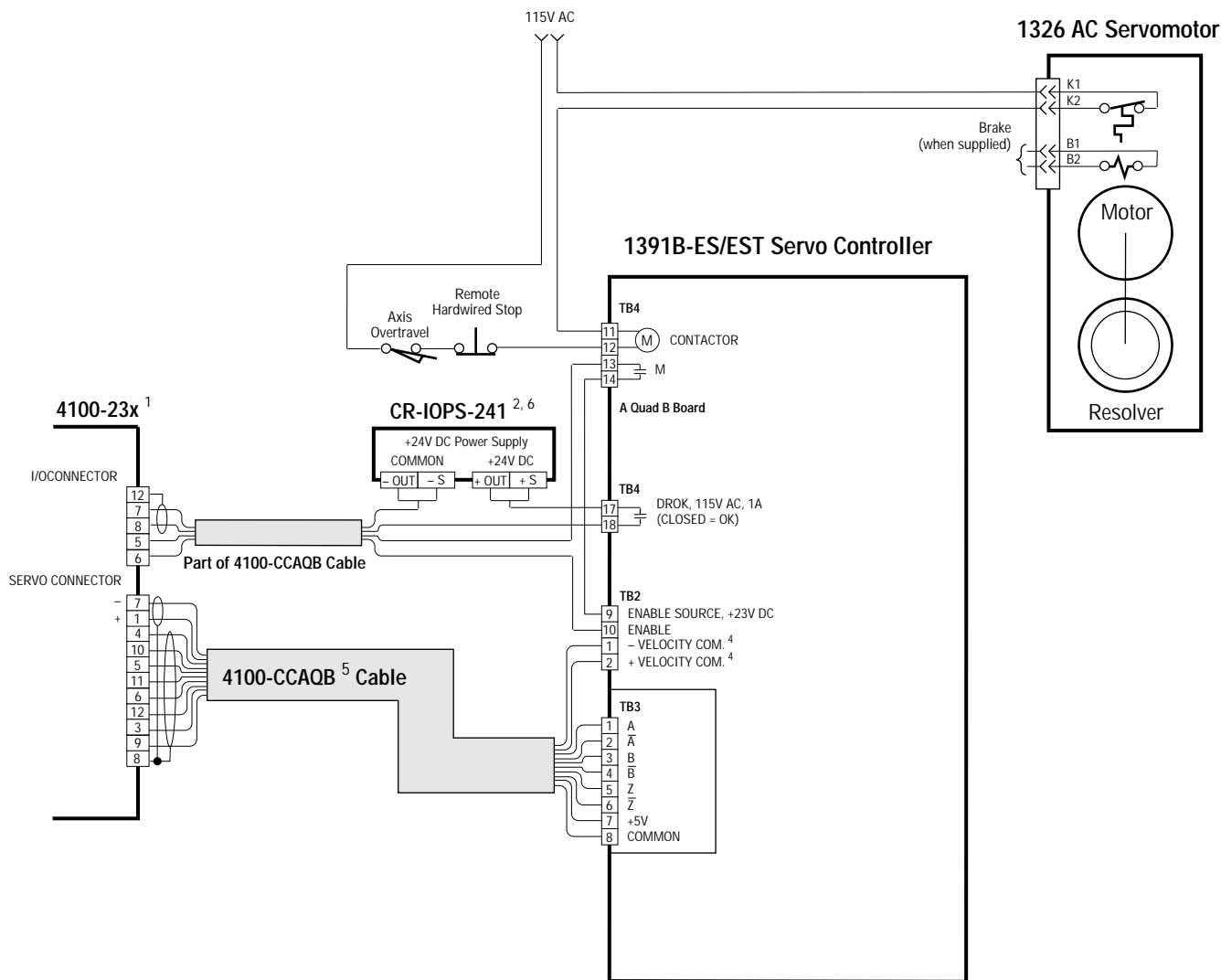
- 1 Refer to the IMC-S/20x Installation and Setup Manual (999-105) and the 1391B-ES Interconnect Drawing for further details.
- 2 Use Belden brand #8760 or equivalent shielded cable.
- 3 Use Belden brand #9504 or equivalent twisted pair, shielded cable, 40 feet (12.2 meters) maximum. Shields grounded at controller only.
- 4 Use Belden brand #9533 or equivalent shielded cable.
- 5 Axis 0 (TB3) connections are shown – Axis 1, 2, 3 connections are identical (use TB5 for Axis 1, TB4 for Axis 2, and TB6 for Axis 3).
- 6 If the drive is to be operated as a torque block, command wires should be connected to 1391B-ES TB2-15, 16 & 17.

Figure B.7  
Typical IMC-S/21x Interconnect Diagram



- <sup>1</sup> Refer to the IMC-S/21x Installation and Setup Manual (999-103) and the 1391B-ES Interconnect Drawing for further details.
- <sup>2</sup> Use Belden brand #8760 or equivalent shielded cable.
- <sup>3</sup> Axis 0 connections (TB1) are shown – Axis 1, 2, 3 connections are identical (use TB3 for Axis 1, TB4 for Axis 2 and TB5 for Axis 3).
- <sup>4</sup> If the drive is to be operated as a torque block, command wires should be connected to 1391B-ES TB2-15, 16 & 17.

Figure B.8  
Typical IMC-S/23x Interconnect Diagram



<sup>1</sup> Refer to the IMC-S/23x Installation and Setup Manual and the 1391B-ES Interconnect Drawing for further details.

<sup>2</sup> Use Belden brand #8760 or equivalent shielded cable.

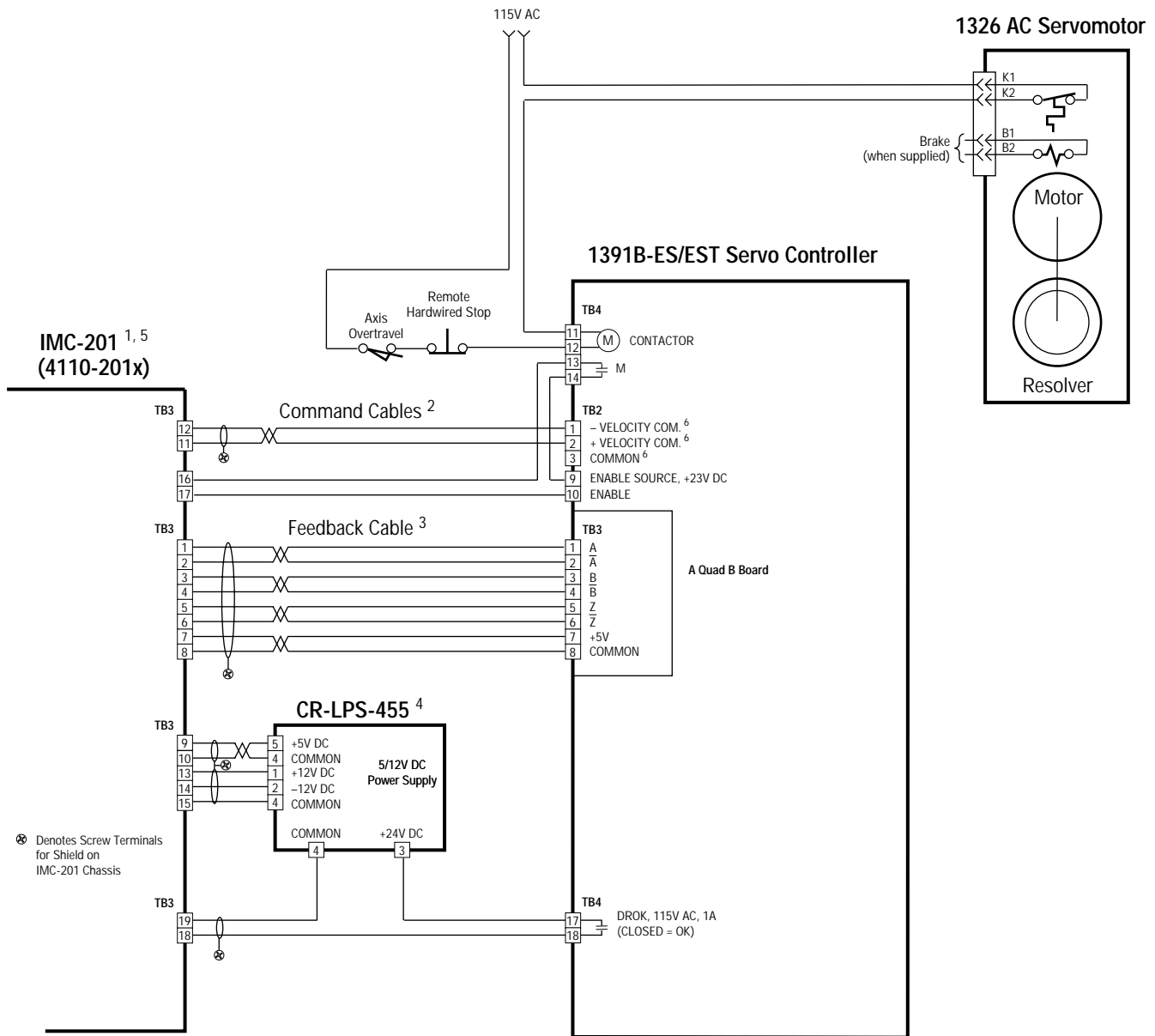
<sup>3</sup> Axis 0 connections are shown – Axis 1, 2, 3 connections are identical.

<sup>4</sup> If the drive is to be operated as a torque block, command wires should be connected to 1391B-ES TB2-15, 16 & 17.

<sup>5</sup> 4100-CCAQB cable assembly is a combination of the 4100-CCSxxF (servo and AQB) and 4100-CCAxxF (enable, I/O, fault). 4100-CCAQB can only be used on 1391C-HB, 1391B-ES and 1391-DES controllers.

<sup>6</sup> Separate from the 24V DC I/O power supply.

Figure B.9  
Typical IMC-201 Interconnect Diagram



- 1 Refer to the IMC-201 Installation and Setup Manual (999-108) and the 1391B-ES Interconnect Drawing for further details.
- 2 Use Belden brand #8760 or equivalent shielded cable.
- 3 Use Belden brand #9504 or equivalent twisted pair, shielded cable, 40 feet (12.2 meters) maximum. Shields grounded at controller only.
- 4 Use Belden brand #9533 or equivalent shielded cable.
- 5 X Axis (TB3) connections are shown – secondary feedback (TB5) connections are identical to the TB3 connections.
- 6 If the drive is to be operated as a torque block, command wires should be connected to 1391B-ES TB2-15, 16 & 17.

Figure B.10  
9/ Series Interconnect Diagram

For detailed 9/Series interconnect information, please refer to the following publications:

| <u>Controller</u> | <u>Publication</u>   |
|-------------------|--|
| 9/240             | 9/240 Integration Manual, publication 8520-4.1                 |
| 9/230, 9/260, 290 | 9/230, 9/260 or 9/290 Integration Manual, publication 8520-6.2 |

Page C-2

Outer shield has been added to the following cable information.

1326-CEUxx Encoder Feedback Cable

| <b>Pair</b>          | <b>Wire Color</b> | <b>Gauge (AWG)</b> | <b>Connector Pin</b> |
|----------------------|-------------------|--------------------|----------------------|
| 1                    | Black             | 22                 | H                    |
|                      | White             | 22                 | A                    |
| 2                    | Black             | 22                 | F                    |
|                      | Red               | 22                 | D                    |
| 3                    | Black             | 22                 | J                    |
|                      | Orange            | 22                 | C                    |
| 4                    | Black             | 22                 | I                    |
|                      | Blue              | 22                 | B                    |
| 5                    | Black             | 22                 | F                    |
|                      | Green             | 22                 | E                    |
| Outer Shield (Drain) |                   |                    | G                    |

Page C-3

The table heading for the 1391-CAQB Cable has been clarified.

| <u>Cable, D-Shell</u>  |                   | <u>Connection on 1391B-ES Controller</u> |                 |                 |
|------------------------|-------------------|--|-----------------|-----------------|
| <b>Terminal Number</b> | <b>Wire Color</b> | <b>Signal</b>                            | <b>Terminal</b> | <b>Location</b> |

Connection of a variable DC supply was described incorrectly. In addition, the last paragraph has been clarified. Please refer to the corrected information below

It is possible to connect a variable 8.0V DC voltage supply to TB2-18 (+) and 20 (-). Varying the voltage at TB2-18 will modify the current limit of the controller as set by selector switch S1 (this rating will not exceed 200% of the controller current rating).

Available current is proportional to the applied voltage as shown in the table below.

| <b>Voltage at TB2-18, 20</b> | <b>Peak Current <sup>3</sup> Percentage</b> |
|------------------------------|---|
| 0V DC or Open Circuit        | 300% <sup>1</sup>                           |
| 3.0V DC                      | 200%  |
| 5.6V DC                      | 100%  |
| 8.0V DC <sup>2</sup>         | 0%  |

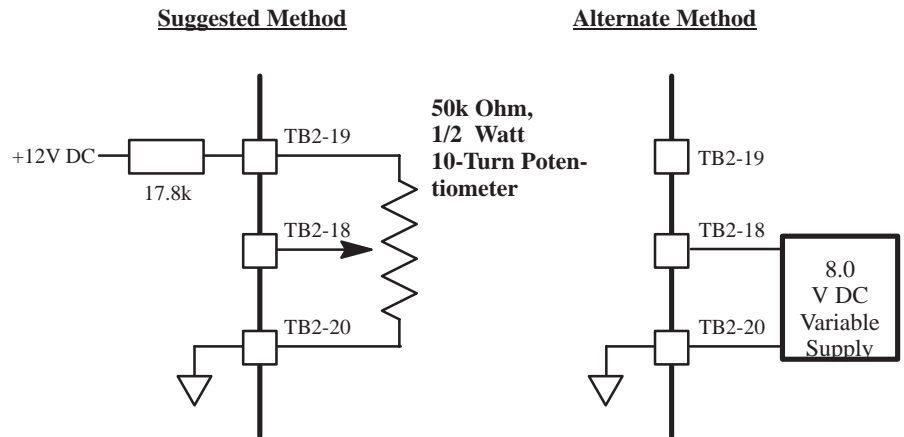
<sup>1</sup> 300% torque of the S1 setting or 200% of drive rating, whichever is less.

<sup>2</sup> Short between TB2-18 and 19 will also give zero current.

<sup>3</sup> Approximate, check TP21 for an exact amount.

The Zero Current option approximates, but may not exactly produce zero current and torque due to tolerances inherent in the drive and components. Offset torque may approach 10% of motor rated torque.

Figure D.1  
Option Connection



Notes