

ACCU ELECTRIC MOTORS INC

USA: (888) 932-9183

CANADA: (905) 829-2505

- ✓ Over 100 years cumulative experience
- ✓ 24 hour rush turnaround / technical support service
- ✓ Established in 1993



The leading independent repairer of servo motors and drives in North America.

Visit us on the web:

www.servo-repair.com

www.servorepair.ca

www.ferrocontrol.com
www.sandvikrepair.com
www.accuelectric.com

Scroll down to view your document!

For 24/7 repair services :

USA: 1 (888) 932 - 9183

Canada: 1 (905) 829 -2505

Emergency After hours: 1 (416) 624 0386

Servicing USA and Canada

1000 SERIES DC SERVOMOTORS

Brush, Rotary Servomotors

- Dynamically balanced, skewed rotor for exceptionally smooth velocity
- Standard NEMA 23, 34, and 42 frame sizes
- Standard stainless-steel shaft resists corrosion
- Double shielded bearing for long motor life
- Options include tachometer, encoders, metric flange, and integral cable



The 1000 series motors are Aerotech's high-performance brush-type rotary DC servomotors. These motors are designed for a variety of general and high-performance motion control applications. Custom mechanical or electrical configurations are also available with minimal lead time.

Skewed Rotor is Better

The 1000 series DC motors feature a dynamically-balanced skewed rotor

and tachometer assembly for less cogging and smoother velocity control. The skewed laminations help reduce the effects of torque ripple that can cause velocity disturbance. The result is a much smoother velocity profile for such applications as machine tool, medical, semiconductor, and scanning.

Standard NEMA Frames

The 1000 series motors come in standard NEMA frame sizes including 23, 34, and 42. The standardized flange and shaft dimensions make it easy to mount to existing NEMA-based machines.

Each motor is constructed from high-grade materials including a stainless-steel shaft, double-shielded bearings, and precision machined housing. Full burn-in of each motor ensures long-term reliable operation.

from 0.25 N-m (35 oz-in) to 1.48 N-m (210 oz-in). Peak output torque ranges from 1.84 N-m (260 oz-in) to 7.1 N-m (1000 oz-in).

Customized for any Application

Standard motor models are available with and without a DC tachometer in different voltage gradients. Options include alternate windings, metric shafts and flanges, encoders with line driver or amplified sine-wave output, rear housings with integral cables, or MS-style heavy-duty connectors.

AEROTECH ADVANTAGES



Highly skewed armature and tachometer provide superior velocity stability and control.

Wide Torque Range

The 1000 series DC motors cover a wide range of torque to meet virtually all high-end DC motor applications. Continuous output torque ranges



1000 Series Rotary Motor Specifications

MOTOR MODEL	UNITS	1035	1050	1135	1210
PERFORMANCE SPECIFICATIONS					
Stall Torque, Continuous	N-m oz-in	0.25 35	0.35 50	0.95 135	1.48 210
Peak Torque	N-m oz-in	1.84 260	2.52 355	5.22 736	7.1 1000
Maximum Speed	rpm	6,000	6,000	5,000	3,000
Rated Power	W hp	129 0.2	146 0.2	200 0.3	220 0.3
ELECTRICAL SPECIFICATIONS					
Winding Designation		-01	-01	-01	-01
Continuous Stall Current	Amps	4.1	5.4	5.5	6.0
Torque Constant	N-m/Amp oz-in/Amp	0.06 8.5	0.07 9.3	0.17 24.5	0.25 35.0
Terminal Resistance	ohms	0.9	0.7	1.4	1.8
BEMF Constant	$V_{pk}/krpm$	6.3	6.9	18.2	25.9
Armature Inductance	mH	2.0	2.5	3.1	4.9
Armature Moment of Inertia	kg-m ² oz-in-s ²	3.8x10 ⁻⁵ 0.005	5.7x10 ⁻⁵ 0.008	3.5x10 ⁻⁴ 0.052	9.2x10 ⁻⁴ 0.13
Recommended Bus Voltage	VDC	40	40	80	80
Maximum Terminal Voltage	VDC	72	72	104	137
Motor Constant	N-m/ \sqrt{W} oz-in/ \sqrt{W}	0.063 9.0	0.084 11.1	0.14 20.7	0.17 26.1
MECHANICAL SPECIFICATIONS					
Frame Size	NEMA	23	23	34	42
Motor Weight Without Tach	kg lb	1.2 2.5	1.6 3.5	3.7 8.1	4.1 9.0
Motor Weight With Tach	kg lb	1.6 3.5	2.1 4.5	4.6 10.1	5.2 11.5
Shaft Radial Load (Max) at Max Speed	N lb	44 10		89 20	134 30

ROTARY MOTORS

AEROTECH ADVANTAGES



1000 Series DC motors are manufactured to ISO9001 standards.



Aerotech has extensive in-house design and manufacturing capabilities. Custom configurations are available for all products.

AEROTECH ADVANTAGES



The 1000 Series DC motors can be teamed with Aerotech's BA series amplifiers for a performance-matched system.



1000 Series Rotary Motor Performance/Dimensions

1035

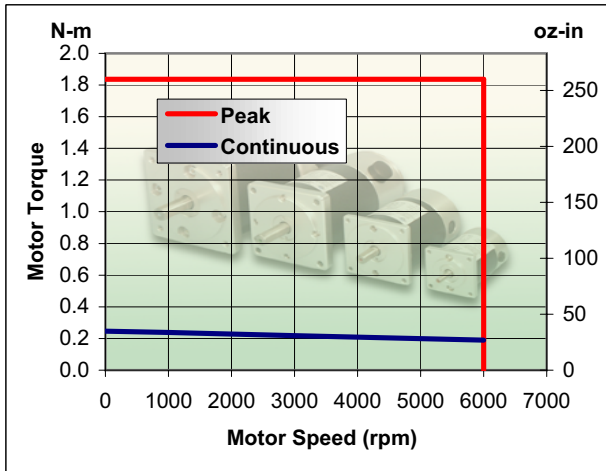

1050

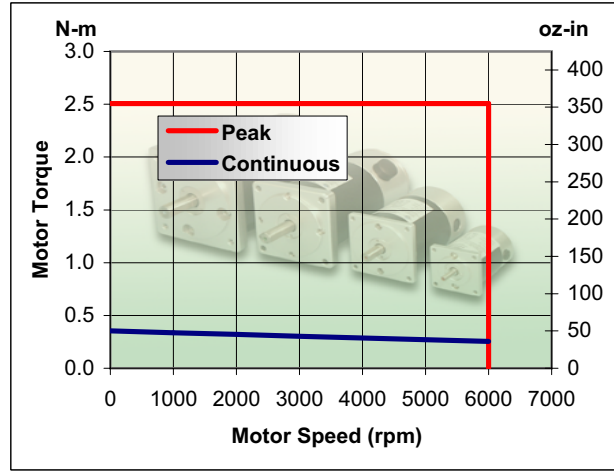

1135

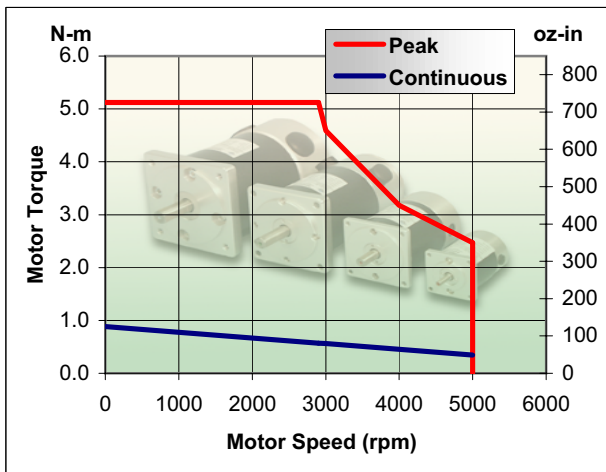

1210

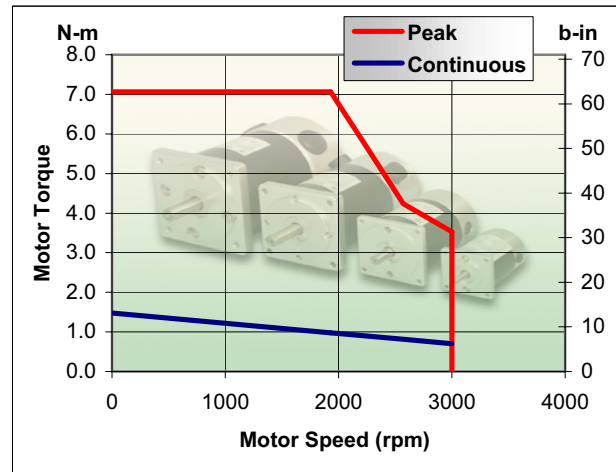

ROTARY MOTORS

NEMA 23

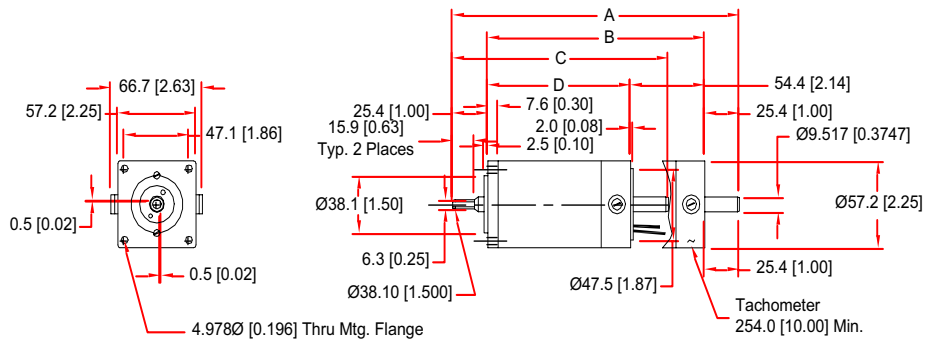

Model Name	Dimensions - Millimeters [Inches]			
	A	B	C	D
1035LT	-	-	157.2 [6.19]	104.4 [4.11]
1050LT	-	-	177.5 [6.99]	124.7 [4.91]
1035DC	209.6 [8.25]	158.2 [6.25]	-	-
1050LT	229.5 [9.05]	178.5 [7.05]	-	-



1000 Series Rotary Motor Dimensions

NEMA 34

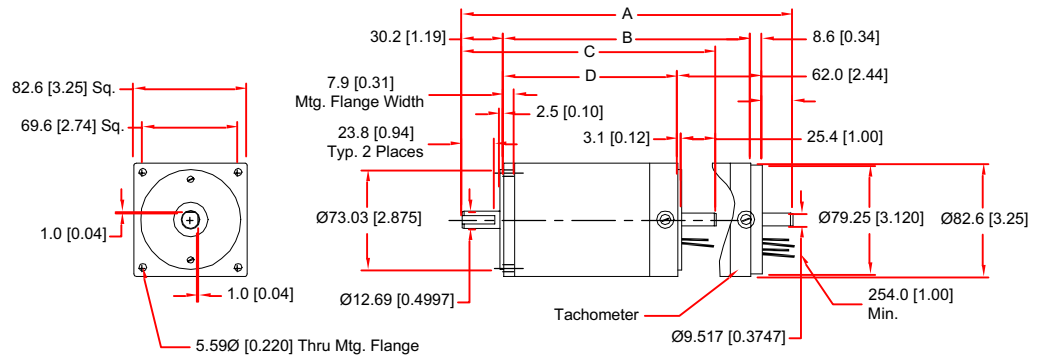

Model Name	Dimensions - Millimeters [Inches]				
	A	B	C	D	
1135DC	278.1 [10.95]	215.4 [8.48]	-	-	23.9 [0.94]
1135LT	-	-	220.7 [8.69]	162.1 [6.38]	-

NEMA 42

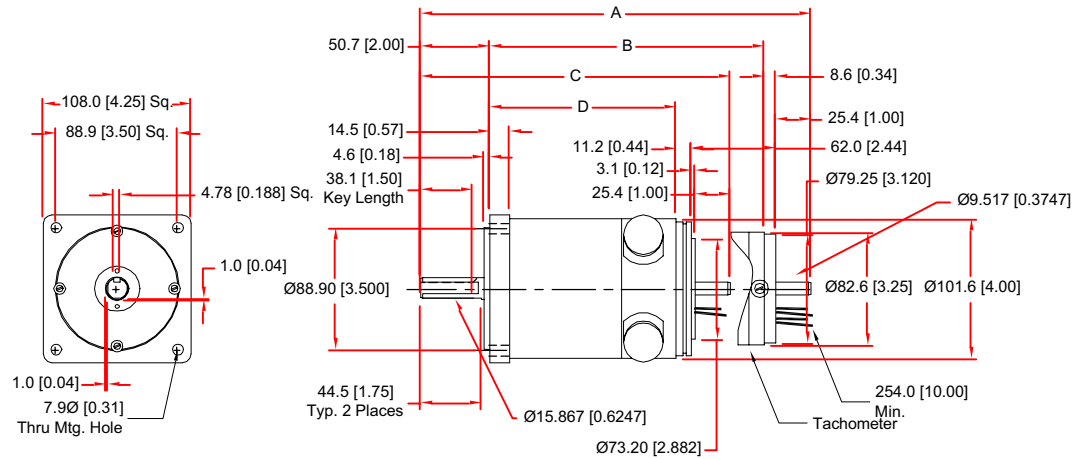

Model Name	Dimensions - Millimeters [Inches]			
	A	B	C	D
1210DC	285.0 [11.22]	200.2 [7.88]	-	-
1210LT	-	-	226.1 [8.90]	135.6 [5.34]

ROTARY MOTORS



This CAD can be downloaded from our web site.



1000 Series Rotary Motor Dimensions

NEMA 23 Motor Cans

MS01: End-Exit Connector

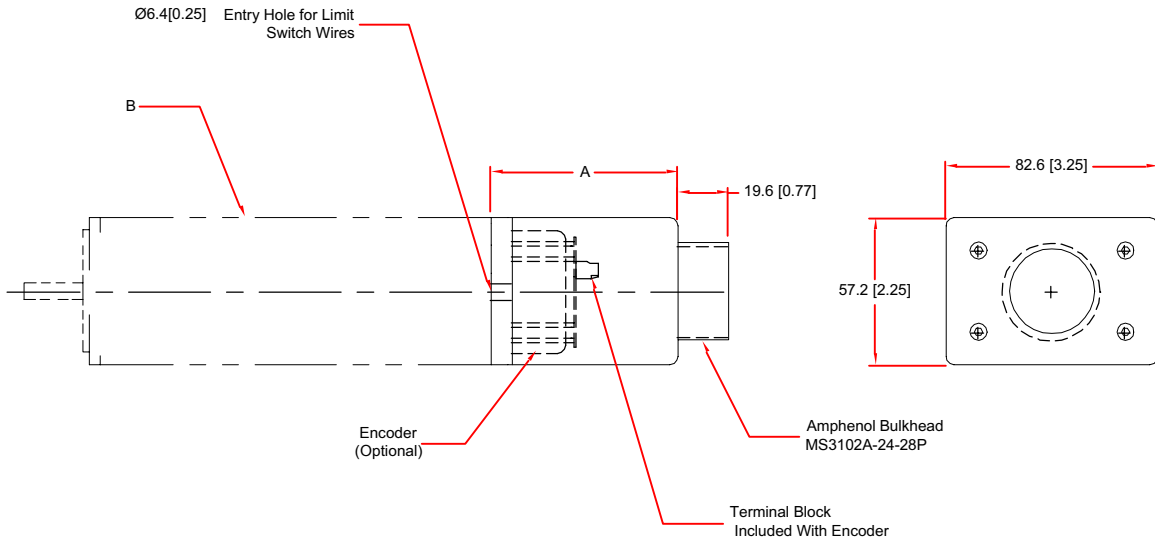

Dimensions - millimeter [inches]

A	B
72.6[2.86]	1035LT 1050LT
73.9[2.91]	1035DC 1050DC

MS0F: Side-Exit Connector

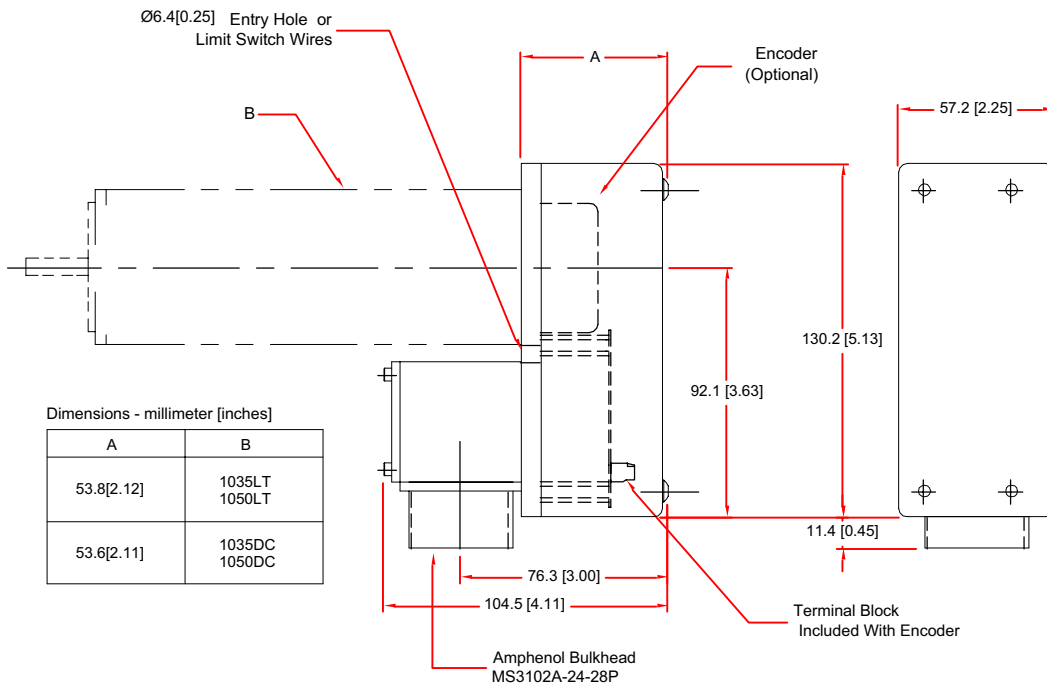

Dimensions - millimeter [inches]

A	B
53.8[2.12]	1035LT 1050LT
53.6[2.11]	1035DC 1050DC

1000 Series Rotary Motor Connection and Termination Options

NEMA 34 Motor Cans

MSO1: Side-Exit Connector

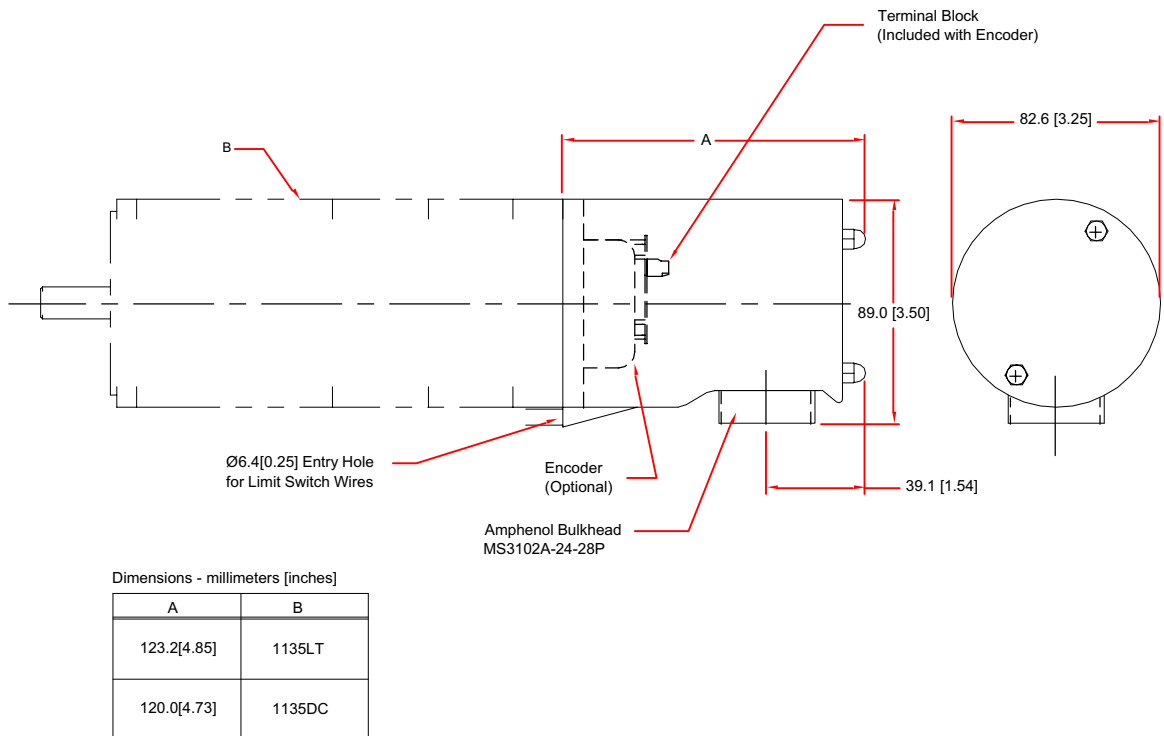

MSOF: Side-Exit Connector

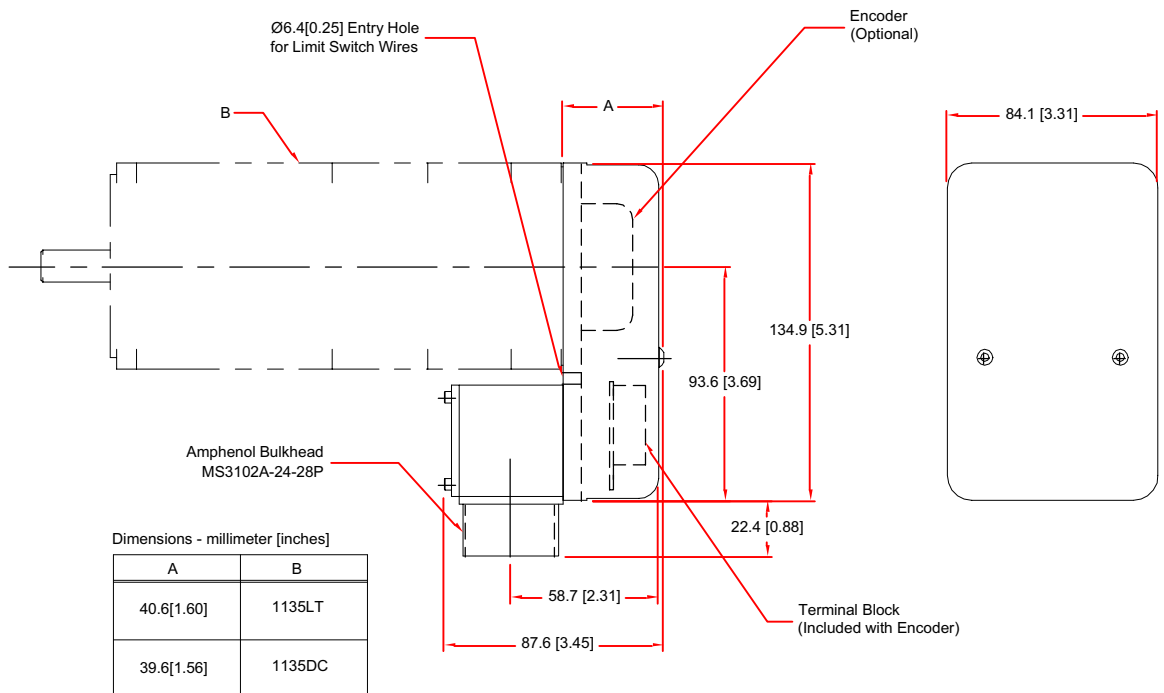

ROTARY MOTORS



1000 Series Rotary Motor Connection and Termination Options

NEMA 42 Motor Cans

MSO1 Side-Exit Connector

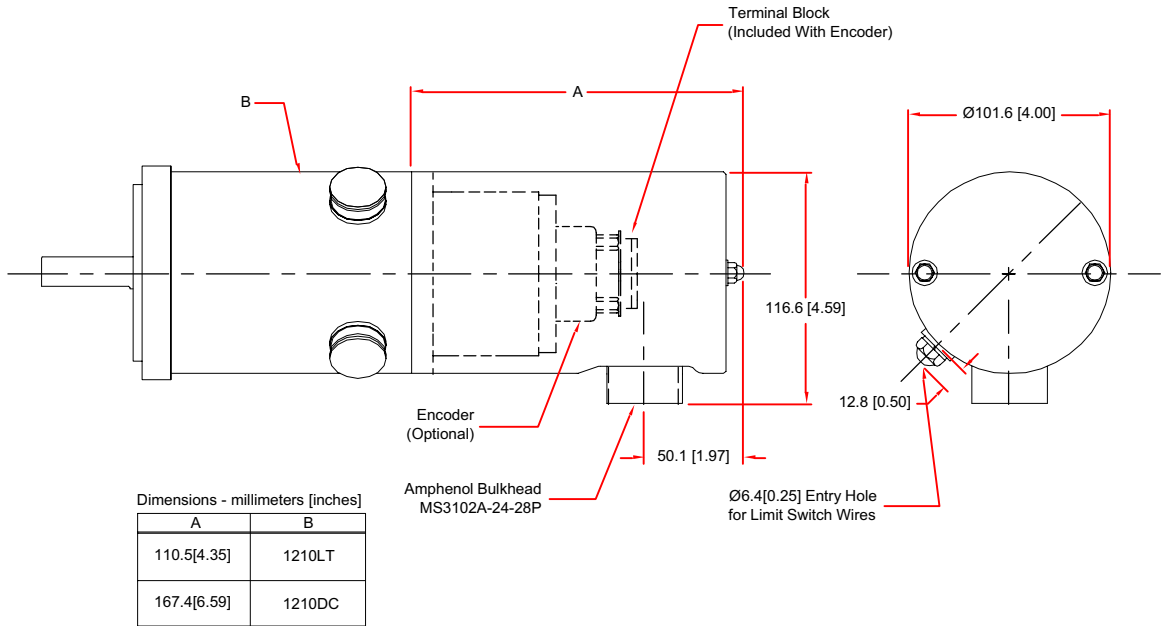

MST Side-Exit Conduit Fitting

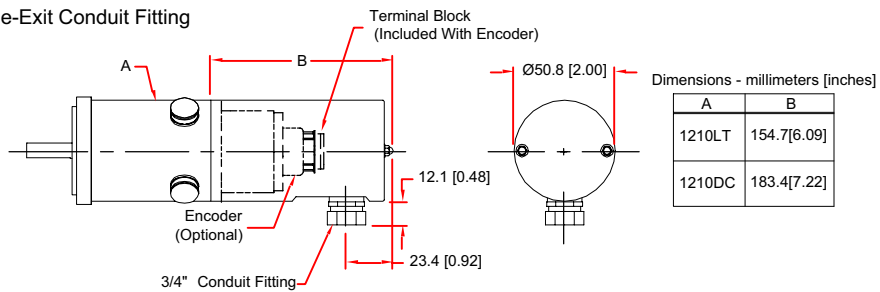

1000 Series Rotary Motor Ordering Information

PART NUMBER AND ORDERING EXAMPLE: 1135DC-MSOF-E2000AS (MOTOR & TACHOMETER & ENCODER)

1	135	DC	MSOF	E2000	AS
Model	Motor Size (continuous torque in oz-in)	Tachometer Option	Termination	Encoder Line Count Per Revolution	Encoder Output
1000 Series DC Motors	035, 050, 135, 210	DC = Standard motor and tachometer winding LT = Standard motor winding (no tach)	(none) = Flying leads (std) MSO1 = Encoder can, MS conn, REAR exit for NEMA 23, SIDE exit for NEMA 34 & 42 motors MSOF = Encoder can, MS conn, low-profile SIDE exit MST = Encoder can, conduit fitting, SIDE exit (NEMA 42) DC2 = Encoder can NEMA 23 only, 15' integral cable, motor END exit, plugs into DR500/U511 chassis DC3 = Same and DC2 for NEMA 34 DC3E = Same as DC2E for NEMA 34 W100 = Wires DC2, DC3, DC2E, DC3E for U100 connection	200, 500, 1000 (std), 1250, 2000	LD = RS-422 line driver (std) AS = Amplifier sine wave

DC Permanent Magnet Servomotors

2 1/4" Diameter, NEMA 23 Models

1035LT	Tcont=0.25 N-m (35 oz-in) DC servomotor
1035DC	Tcont=0.25 N-m (35 oz-in) DC servomotor with 3V/krpm tachometer
1050LT	Tcont=0.35 N-m (50 oz-in) DC servomotor
1050DC	Tcont=0.35 N-m (50 oz-in) DC servomotor with 3V/krpm tachometer

Options (NEMA 23 Models)

-E200AS - E1000AS	Encoder, 3 channel, amplified sine output
-E2000AS	High density encoder, 3 channel, amplified sine output
-E200LD - E1000LD	Encoder, 3 channel, line driver output
-E2000LD	High density encoder, 3 channel, line driver output
-DC2	Rear housing, side-exit integral cable with connector (LT motor only)
-DC2E	Rear housing, end-exit integral cable with connector
-MSO1	Rear housing, end-exit connector
-MSOF	Rear housing, side-exit connector
-VAC	Vacuum preparation of motor or motor-tach to 10E-6 Torr
-02 or -03	Non-standard tachometer winding

3 1/4" Diameter, NEMA 34 Models

1135LT	Tcont=0.95 N-m (135 oz-in) DC servomotor
1135DC	Tcont=0.95 N-m (135 oz-in) DC servomotor with 3V/krpm tachometer

Options (NEMA 34 Models)

-E200AS - E1000AS	Encoder, 3 channel, amplified sine output
-E2000AS	High density encoder, 3 channel, amplified sine output
-E200LD - E1000LD	Encoder, 3 channel, line driver output
-E2000LD	High density encoder, 3 channel, line drive output
-DC3	Rear housing, side-exit integral cable with connector
-MSO1	Rear housing, side-exit connector
-MSOF	Rear housing, right angle low-profile with side-exit connector (shorter than MSO1)
-VAC	Vacuum preparation of motor or motor-tach to 10E-6 Torr
-02 or -03	Non-standard tachometer winding



1000 Series Rotary Motor Ordering Information

4" Diameter NEMA 42 Models

1210LT	Tcont=1.48 N-m (210 oz-in) DC servomotor
1210DC	Tcont=1.48 N-m (210 oz-in) DC servomotor with 3V/krpm tachometer

Options (NEMA 42 Models)

E200AS - E1000AS	Encoder, 3 channel, amplified sine output
E2000AS	High density encoder, 3 channel, amplified sine output
E200LD - E1000LD	Encoder, 3 channel, line driver output
E2000LD	High density encoder, 3 channel, line driver output
-MSO1	Rear housing, side-exit connector
-MST	Rear housing, side-exit conduit fitting
-VAC	Vacuum preparation of motor or motor-tach to 10E-6 Torr
-02 or -03	Non-standard tachometer winding



We constantly improve
the quality and performance
of our products. Please
check our web site for the
most current specifications.

